

# ACCESSORIES & OTHERS

<b>■ Accessories</b>	<b>Page</b>
● Air Bleed Valves .....	820
● “F3” Series Pipe Flange Kits .....	821
● “F5” Series Pipe Flange Kits .....	824
● “F6” Series Pipe Flange Kits .....	829
<b>■ Data Sheet</b>	
● Size of O-Ring .....	833
● SAE J1926-1 SAE Straight Thread O-Ring Port.....	835

## Air Bleed Valves

These air bleed valves are designed to use, at the start-up of the pumps, to bleed off the air enclosed in the suction line or the other lines in the system.

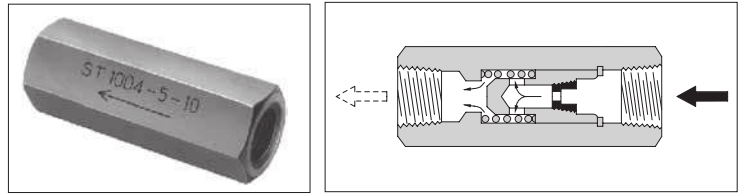

### Specifications

Model Numbers	Max. Operating Pressure MPa (PSI)	Reseating Pressure MPa (PSI)	Cracking Pressure MPa (PSI)	Flow Rate to Reseating L/min (U.S.GPM)	Range of Usage to Pump Output Flow	Approx. Mass kg (lbs.)
ST1004-5-10*	25 (3630)	0.15 (22)	0.34 (49)	5 (1.32)	For 20 to 75 L/min (5.28 to 19.8 U.S.GPM)	0.2 (.44)
ST1004-10-10*				10 (2.64)	For Over 75 L/min (19.8 U.S.GPM)	

### Model Number Designation

ST1004	-5	-10	*
Series Number	Flow Rate to Reseating	Design Number	Design Standards
<b>ST1004:</b> Air Bleed Valve	<b>5:</b> 5 L/min (1.32 U.S.GPM) <b>10:</b> 10 L/min (2.64 U.S.GPM)	<b>10</b>	<b>None:</b> Japanese Standard "JIS" <b>80:</b> European Design Standard <b>90:</b> N. American Design Standard

### Instructions

When the valve is used to bleed off the air from the pump, connect the inlet port of the valve to the discharge port of the pump as close as possible. When removing the air from the pipes, install the valve at the highest position of the system. In either case, the outlet port of the valve must be connected to the tank, the end of which is located below the oil level in the reservoir.

### Graphic Symbol

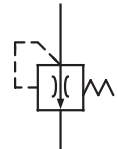

### Hydraulic Fluids

#### Type of Hydraulic Fluids

Petroleum Base Oils .....Use R & O (Rust and Oxidation inhibitor) type oils or anti-wear type oils (equivalent to ISO VG-32 or 46)

Synthetic Fluids .....Use phosphate ester type fluid or polyol ester type fluids.

Water Containing Fluids ..Use water glycol type fluids or water in oil emulsion type fluids.

Other Special Fluids .....Consult factory for information.

#### Recommended viscosity and Oil Temperatures

Viscosity ranging between 15 and 400 mm<sup>2</sup>/s (77 and 1800 SSU).

Oil temperatures between -15 and +70°C (5 and 160°F)

Use hydraulic fluids which satisfy the recommended viscosity and oil temperatures given above.

#### Filtration Recommended...25 microns or less.

ST1004-\*-10/1080/1090

Model Numbers	"A" Thd.	mm (Inches)	
		B	C
ST1004-*-10	Rc 3/8	70 (2.76)	24 (.94)
ST1004-*-1080	3/8 BSPF	82 (3.23)	27 (1.06)
ST1004-*-1090	3/8 NPT	70 (2.76)	24 (.94)

**DIMENSIONS IN MILLIMETRES (INCHES)**

## “F3” Series Pipe Flange Kits

### Specifications

- Max. Operating Pressure...25 MPa (3630 PSI)

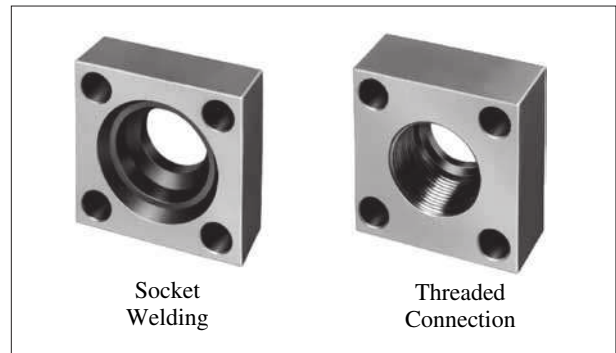

### Model Number Designation

F-	F3	-03W	-A	-N	-11	*
Material of Seal	Series Number	Flange Size	Type of Pipe Connection	O-Ring & Bolts	Design Number	Design * Standards
<b>None:</b> Standard NBR (Buna N) Seal  <b>F:</b> FPM (Viton) Seal (For Synthetic fluids)	F3	03W, 03, 06V 06W, 06, 10W 10, 16W, 16 24W, 24	<b>A:</b> Pipe Socket Welding	<b>None:</b> With O-Ring and Mounting Bolts  <b>N:</b> No O-Ring and Mounting Bolts	11	<b>None:</b> Japanese Standard "JIS" & European Design Standard
		03W, 03, 06V 06, 10W, 10 16W, 16, 24W 24				<b>C:</b> Block Type
		03W, 03, 06V 06W, 06, 10W 10, 16W, 16 24W, 24	<b>B:</b> Threaded Connection	<b>None:</b> With O-Ring and Mounting Bolts  <b>N:</b> No O-Ring and Mounting Bolts	11	<b>None:</b> Japanese Standard "JIS"
		03W, 03, 06V 06, 10W, 10 16W, 16, 24W 24				<b>80:</b> European Design Standard  <b>90:</b> N. American Design Standard

★ Three different design standards are available as shown blow. Select the suitable design standard to your requirement.

Type of Pipe Connection	Design Standard	Pipe Thread	Mounting Bolt (Socket Head Cap Screw)
Pipe Socket Welding Block Type	Japanese Standard "JIS" & European Design Standard	—	Metric Thd.
	N. American Design Standard	—	Unified Thd.
Threaded Connection	Japanese Standard "JIS"	Rc	Metric Thd.
	European Design Standard	BSP.F	Metric Thd.
	N. American Design Standard	NPT	Unified Thd.

■ Pipe Socket Welding

F3-*\**-A\*-11/1190

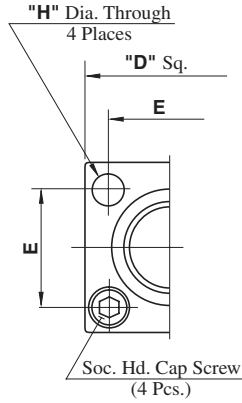

■ Block Type

F3-*\**-C\*-11/1190

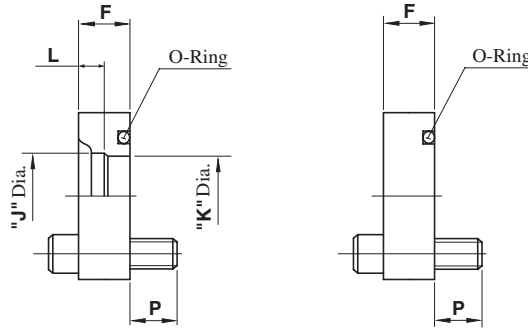

Customer's Mounting Surface

Surface should have a good machined finish.

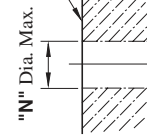

Kit Numbers	Piping Size	Dimensions mm (Inches)									O-Ring	Socket Head Cap Screw	Approx.* Mass kg (lbs.)	
		D	E	F	H	J	K	L	N	P				
F3-03W- <i>*</i> -11	1/4	54 (2.13)	36 (1.42)	21 (.83)	11 (.43)	14.3 (.56)	11 (.43)	8 (.31)	15 (.59)	14 (.55)	SO-NB-G25	M10 × 35 Lg.	0.5 (1.1)	
F3-03W- <i>*</i> -1190						17.1 (.67)	17.8 (.70)	12.5 (.49)		9 (.35)		14 (.55)		3/8-16UNC × 1-1/2 Lg.
F3-03- <i>*</i> -11	3/8	58 (2.28)	40 (1.57)	21 (.83)	11 (.43)	17.8 (.70)			12.5 (.49)			9 (.35)		14 (.55)
F3-03- <i>*</i> -1190						17.1 (.67)	3/8-16UNC × 1-1/2 Lg.							
F3-06V- <i>*</i> -11	3/8	58 (2.28)	40 (1.57)	21 (.83)	11 (.43)	17.8 (.70)	12.5 (.49)	9 (.35)	20 (.79)	14 (.55)	SO-NB-G30	M10 × 35 Lg.	0.8 (1.8)	
F3-06W- <i>*</i> -11	1/2					22.2 (.87)	16 (.63)	11 (.43)		14 (.55)		3/8-16UNC × 1-1/2 Lg.		
F3-06W- <i>*</i> -1190						3/4	27.7 (1.09)	20 (.79)		12 (.47)		14 (.55)		M10 × 35 Lg.
F3-06- <i>*</i> -11	17.1 (.67)						3/8-16UNC × 1-1/2 Lg.							
F3-10W- <i>*</i> -11	1	76 (2.99)	56 (2.20)	27 (1.06)	13.5 (.53)	34.5 (1.36)	25 (.98)	14 (.55)	31.5 (1.24)	18 (.71)	SO-NB-G40	M12 × 45 Lg.	1.4 (3.1)	
F3-10W- <i>*</i> -1190	1-1/4					17.5 (.69)	43.2 (1.70)	31.5 (1.24)		16 (.63)		17.5 (.69)		1/2-13UNC × 1-3/4 Lg.
F3-10- <i>*</i> -11						3						18 (.71)		49.1 (1.93)
F3-10- <i>*</i> -1190	17.5 (.69)						1/2-13UNC × 1-3/4 Lg.							
F3-16W- <i>*</i> -11	1-1/2	100 (3.94)	73 (2.87)	35 (1.38)	17.5 (.69)	49.1 (1.93)	37.5 (1.48)	18 (.71)	50 (1.97)	25 (.98)	SO-NB-G60	M16 × 60 Lg.	2.7 (6.0)	
F3-16W- <i>*</i> -1190	2					22.1 (.87)	61.1 (2.41)	47.5 (1.87)		20 (.79)		22.1 (.87)		8/5-11UNC × 2-1/4 Lg.
F3-16- <i>*</i> -11						3						25 (.98)		77.1 (3.04)
F3-16- <i>*</i> -1190	22.1 (.87)						8/5-11UNC × 2-1/4 Lg.							
F3-24W- <i>*</i> -11	2-1/2	140 (5.51)	103 (4.06)	44 (1.73)	24 (.94)	77.1 (3.04)	60 (2.36)	22 (.87)	75 (2.95)	36 (1.42)	SO-NB-G85	M22 × 80 Lg.	5.8 (12.8)	
F3-24W- <i>*</i> -1190	3					38.6 (1.52)	90.0 (3.54)	71 (2.80)		25 (.98)		36 (1.42)		7/8-9UNC × 3-1/4 Lg.
F3-24- <i>*</i> -11						3						36 (1.42)		90.0 (3.54)
F3-24- <i>*</i> -1190	38.6 (1.52)						7/8-9UNC × 3-1/4 Lg.							

★ Approx. mass is the value including socket head cap screws (4 Pcs.).

Threaded Connection

Japanese Standard "JIS" & N. American Design Standard

F3-\*-B\*-11/1190

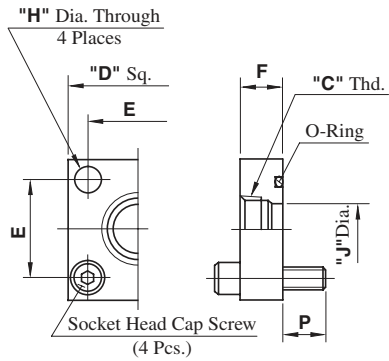

European Design Standard

F3-\*-B\*-1180

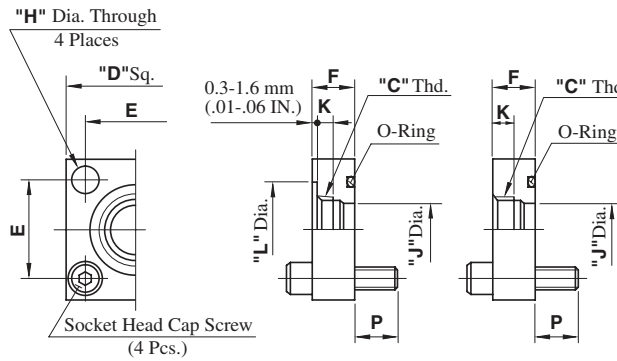

Customer's Mounting Surface

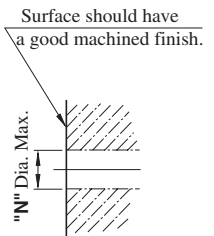

Piping Size: 03W to 10

Piping Size: 16W to 24

Kit Numbers	Piping Size "C" Thd.	Dimensions mm (Inches)									O-Ring	Socket Head Cap Screw	Approx.* Mass kg (lbs.)		
		D	E	F	H	J	K	L	N	P					
F3-03W-B*-11	Rc 1/4					11 (.43)	—	—				14 (.55)	SO-NB-G25	M10 × 35 Lg.	0.5 (1.1)
F3-03W-B*-1180	1/4 BSPF					11.5 (.45)	12 (.47)	21 (.83)			15 (.59)	17.1 (.67)		3/8-16UNC × 1-1/2 Lg.	
F3-03W-B*-1190	1/4 NPT	54 (2.13)	36 (1.42)	21 (.83)	11 (.43)	11 (.43)	—	—			14 (.55)	14 (.55)	M10 × 35 Lg.		
F3-03-B*-11	Rc 3/8					15 (.59)	14 (.55)	24.3 (.96)			17.1 (.67)	17.1 (.67)	3/8-16UNC × 1-1/2 Lg.		
F3-03-B*-1180	3/8 BSPF					14 (.55)	—	—							
F3-03-B*-1190	3/8 NPT					14 (.55)	—	—							
F3-06V-B*-11	Rc3/8					14 (.55)	—	—				14 (.55)	SO-NB-G30	M10 × 35 Lg.	0.8 (1.8)
F3-06W-B*-11	Rc 1/2			21 (.83)		17.5 (.69)	—	—			20 (.79)	14 (.55)		M10 × 35 Lg.	
F3-06W-B*-1180	1/2 BSPF	58 (2.28)	40 (1.57)		11 (.43)	19 (.75)	17 (.67)	29 (1.14)			17.1 (.67)	17.1 (.67)	3/8-16UNC × 1-1/2 Lg.		
F3-06W-B*-1190	1/2 NPT					17.5 (.69)	—	—			13 (.51)	13 (.51)	M10 × 40 Lg.		
F3-06-B*-11	Rc 3/4			27 (1.06)		24.5 (.96)	20 (.79)	35.5 (1.40)			17.5 (.69)	17.5 (.69)	3/8-16UNC × 1-3/4 Lg.		
F3-06-B*-1180	3/4 BSPF					23 (.91)	—	—							
F3-06-B*-1190	3/4 NPT					23 (.91)	—	—							
F3-10W-B*-11	Rc 1					29 (1.14)	—	—				18 (.71)	SO-NB-G40	M12 × 45 Lg.	1.4 (3.1)
F3-10W-B*-1180	1 BSPF			27 (1.06)		30.5 (1.20)	21 (.83)	43.5 (1.71)			31.5 (1.24)	17.5 (.69)		1/2-13UNC × 1-3/4 Lg.	
F3-10W-B*-1190	1 NPT	76 (2.99)	56 (2.20)		13.5 (.53)	29 (1.14)	—	—			15 (.59)	15 (.59)	M12 × 50 Lg.		
F3-10-B*-11	Rc 1-1/4			35 (1.38)		31.5 (1.24)	22 (.87)	53 (2.09)			15.8 (.62)	15.8 (.62)	1/2-13UNC × 2 Lg.		
F3-10-B*-1180	1-1/4 BSPF					—	—	—							
F3-10-B*-1190	1-1/4 NPT					—	—	—							
F3-16W-B*-11	Rc 1-1/2					43.5 (1.71)	—	—				25 (.98)	SO-NB-G60	M16 × 60 Lg.	2.7 (6.0)
F3-16W-B*-1180	1-1/2 BSPF			35 (1.28)		45 (1.77)	22 (.87)	—			50 (1.97)	28.5 (1.12)		5/8-11UNC × 2-1/2 Lg.	
F3-16W-B*-1190	1-1/2 NPT	100 (3.94)	73 (2.87)		17.5 (.69)	43.5 (1.71)	—	—			21 (.83)	21 (.83)	M16 × 60 Lg.		
F3-16-B*-11	Rc 2			39 (1.54)		47.5 (1.87)	22 (.87)	—			24.5 (.96)	24.5 (.96)	5/8-11UNC × 2-1/2 Lg.		
F3-16-B*-1180	2 BSPF					—	—	—							
F3-16-B*-1190	2 NPT					—	—	—							
F3-24W-B*-11	Rc 2-1/2					70 (2.76)	—	—				36 (1.42)	SO-NB-G85	M22 × 80 Lg.	5.8 (12.8)
F3-24W-B*-1180	2-1/2 BSPF			44 (1.73)		72.5 (2.85)	20 (.79)	—			75 (2.95)	38.6 (1.52)		7/8-9UNC × 3-1/4 Lg.	
F3-24W-B*-1190	2-1/2 NPT	140 (5.51)	103 (4.06)		24 (.94)	70 (2.76)	—	—			31 (1.22)	31 (1.22)	M22 × 80 Lg.		
F3-24-B*-11	Rc 3			49 (1.93)		71 (2.80)	20 (.79)	—			33.6 (1.32)	33.6 (1.32)	7/8-9UNC × 3-1/4 Lg.		
F3-24-B*-1180	3 BSPF					—	—	—							
F3-24-B*-1190	3 NPT					—	—	—							

\* Approx. Mass is the value including socket head cap screws (4 Pcs.).

## ■ “F5” Series Pipe Flange Kits

The dimensions of the flange mounting surface are based upon SAE 4 Bolt Split Flange (Standard Pressure Series).

### ■ Specifications

#### ● Max. Operating Pressure

Maximum operation pressure varies with the type of pipe connection or flange size. Refer to the applicable installation drawings.

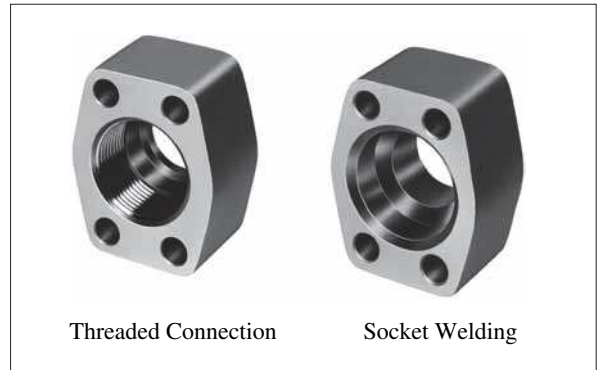

### ■ Model Number Designation

F-	F5	-06	-A	-10	*
Material of Seal	Series Number	Flange Size	Type of Pipe Connection	Design Number	Design Standards*
None: Standard NBR (Buna N) Seal	F5	04W, 04, 06X 06, 08, 08W, 10 12, 16, 16W, 20 24, 28, 32	A: Threaded Connection	10	None: Japanese Standard "JIS"
		04, 06, 08 10, 12, 16 20			80: European Design Standard
		04W, 04, 06 08, 10, 12 16, 16W, 20 24, 28, 32			90: N. American Design Standard
F: FPM (Viton) Seal (For Synthetic Fluids)		04W, 04, 06X 06, 08, 08W, 10 12, 16, 16W, 20 24, 28, 32	B: Socket Welding	10	None: Japanese Standard "JIS" & European Design Standard
		04W, 04, 06 08, 10, 12 16, 16W, 20, 24 28, 32			90: N. American Design Standard
		04, 06, 08 10, 12, 16 20	C: Butt Welding	10	None: Japanese Standard "JIS" & European Design Standard 90: N. American Design Standard

★ Three different design standards are available as shown below. Select the suitable design standard to your requirement.

Type of Pipe Connection	Design Standard	Pipe Thread	Mounting Bolt (Socket Head Cap Screw)
Threaded Connection	Japanese Standard "JIS"	Rc	Metric Thd.
	European Design Standard	BSPF	Metric Thd.
	N. American Design Standard	NPT	Unified Thd.
Pipe Socket Welding Butt Welding	Japanese Standard "JIS" & European Design Standard	—	Metric Thd.
	N. American Design Standard	—	Unified Thd.

Threaded Connection

Japanese Standard "JIS" : F5-\*-A-10  
 N. American Design Standard : F5-\*-A-1090

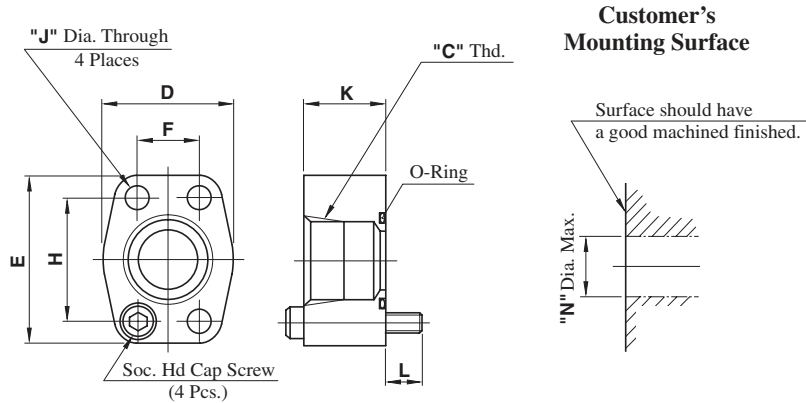

Kit Numbers	Piping Size "C" Thd.	Dimensions mm (Inches)								Socket Head Cap Screw (4 Pcs.)	O-Ring	Max. Operating Pressure MPa (PSI)	Approx. Mass kg (lbs.) <sup>*1</sup>	Recommended Tightening Torque (Tolerance ±10%) Nm (IN.lbs.) <sup>*2</sup>			
		D	E	F	H	J	K	L	N								
F5-04W-A-10	Rc 3/8	40 (1.57)	54 (2.13)	17.5 (.689)	38.1 (1.500)	8.8 (.346)	30 (1.18)	10 (.39)	13 (.51)	M8 × 40 Lg.	SO-NB-P22	28 (4060)	0.5 (1.1)	35 (310)			
F5-04-A-10	Rc 1/2							14.5 (.57)		5/16-18UNC × 1-3/4 Lg.							
F5-04W-A-1090	3/8 NPT																
F5-04-A-1090	1/2 NPT																
F5-06X-A-10	Rc 3/4	48 (1.89)	65 (2.56)	22.2 (.874)	47.6 (1.874)	11 (.433)	8.8 (.346)	15 (.59)	19 (.75)	M8 × 45 Lg.	SO-NB-G30	28 (4060)	0.7 (1.5)	35 (310)			
F5-06-A-10							11 (.433)	14.5 (.57)		M10 × 45 Lg.				68.5 (606)			
F5-06-A-1090							3/4 NPT	3/8-16UNC × 1-3/4 Lg.									
F5-08W-A-10	Rc 3/4	55 (2.17)	70 (2.76)	26.2 (1.031)	52.4 (2.063)	11 (.433)	30 (1.18)	15 (.59)	26 (1.02)	M10 × 45 Lg.	SO-NB-G35	28 (4060)	0.9 (2.0)	68.5 (606)			
F5-08-A-10	Rc 1							14.5 (.57)		3/8-16UNC × 1-3/4 Lg.							
F5-08-A-1090	1 NPT																
F5-10-A-10	Rc 1-1/4	64 (2.52)	80 (3.15)	30.2 (1.189)	58.7 (2.311)	11 (.433)	38 (1.50)	17 (.67)	32 (1.26)	M10 × 55 Lg.	SO-NB-G40	28 (4060)	1.2 (2.6)	68.5 (606)			
F5-10-A-1090	1-1/4 NPT							12 (.472)		19.2 (.76)					7/16-14UNC × 2-1/4 Lg.		
F5-12-A-10	Rc 1-1/2	72 (2.83)	94 (3.70)	35.7 (1.406)	69.9 (2.752)	13.5 (.531)	38 (1.50)	17 (.67)	38 (1.50)	M12 × 55 Lg.	SO-NB-G50	21 (3050)	1.5 (3.3)	118 (1044)			
F5-12-A-1090	1-1/2 NPT							19.2 (.76)		1/2-13UNC × 2-1/4 Lg.							
F5-16W-A-10	Rc 1-1/2	85 (3.35)	102 (4.02)	42.9 (1.689)	77.8 (3.063)	13.5 (.531)	38 (1.50)	17 (.67)	48 (1.89)	63 (2.48)	SO-NB-G60	21 (3050)	1.8 (4.0)	118 (1044)			
F5-16-A-10	Rc 2							51 (2.01)	M12 × 55 Lg.						SO-NB-G65	17.5 (2540)	1.7 (3.8)
F5-16W-A-1090	1-1/2 NPT							48 (1.89)	1/2-13UNC × 2-1/4 Lg.						SO-NB-G60	21 (3050)	1.8 (4.0)
F5-16-A-1090	2 NPT							19.2 (.76)							51 (2.01)	SO-NB-G65	17.5 (2540)
F5-20-A-10	Rc 2-1/2	102 (4.02)	114 (4.49)	50.8 (2.000)	88.9 (3.500)	13.5 (.531)	48 (1.89)	17 (.67)	63 (2.48)	M12 × 65 Lg.	SO-NB-G75	17.5 (2540)	2.0 (4.4)	118 (1044)			
F5-20-A-1090	2-1/2 NPT							21.8 (.86)		1/2-13UNC × 2-3/4 Lg.							
F5-24-A-10	Rc 3	116 (4.57)	135 (5.31)	61.9 (2.437)	106.4 (4.189)	17 (.67)	76 (2.99)	17 (.67)	88 (3.46)	M16 × 70 Lg.	SO-NB-G85	3.5 (510)	2.7 (6.0)	287 (2540)			
F5-24-A-1090	3 NPT							19.2 (.76)		5/8-11UNC x 2-3/4 Lg.							
F5-28-A-10	Rc 3-1/2	134 (5.28)	153 (6.02)	69.9 (2.752)	120.7 (4.752)	17 (.67)	53 (2.09)	17 (.67)	88 (3.46)	M16 × 70 Lg.	SO-NB-G100	3.5 (510)	3.4 (7.5)	287 (2540)			
F5-28-A-1090	3-1/2 NPT							19.2 (.76)		5/8-11UNC x 2-3/4 Lg.							
F5-32-A-10	Rc 4	150 (5.91)	162 (6.38)	77.8 (3.068)	130.2 (5.126)	17 (.67)	101 (3.98)	17 (.67)	101 (3.98)	M16 × 70 Lg.	SO-NB-G115	3.7 (8.2)	3.7 (8.2)	287 (2540)			
F5-32-A-1090	4 NPT							19.2 (.76)		5/8-11UNC x 2-3/4 Lg.							

\*1. Approx. mass is the value including socket head cap screws (4 Pcs.).

\*2. The values of recommended tightening torque are for socket head cap screws and apply to when these flanges are used for pressure line.

■ Threaded Connection

European Design Standard  
F5-\*-A-1180

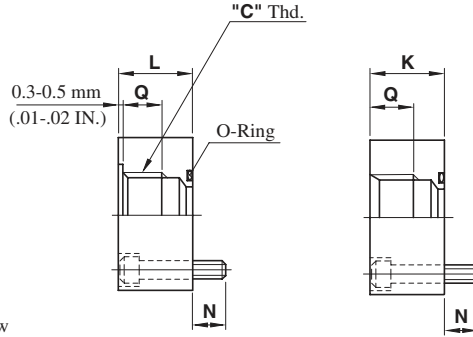
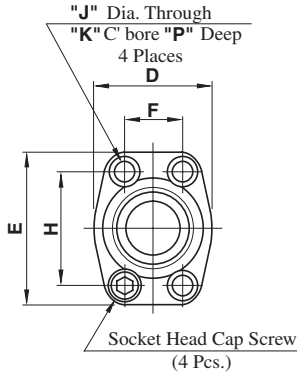

Customer's  
Mounting Surface

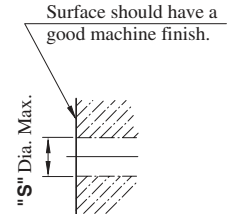

Piping Size:  
1/2 to 1-1/2

Piping Size:  
2 & 2-1/2

Kit Numbers	Piping Size "C" Thd.	Dimensions mm (Inches)										Socket Head Cap Screw (4 Pcs.)	O-Ring	Max. Operating Pressure MPa (PSI)	Approx. Mass kg (lbs.) <sup>*</sup>	
		D	E	F	H	J	K	L	N	P	Q					S
F5-04-A-1080	1/2 BSP.F	40 (1.57)	59 (2.32)	17.5 (.689)	38.1 (1.500)	8.8 (.346)	14 (.55)	31 (1.22)	12.6 (.50)	8.6 (.34)	17 (.67)	15 (.59)	M8 × 35 Lg.	SO-NB-P22	28 (4060)	0.5 (1.1)
F5-06-A-1080	3/4 BSP.F	48 (1.89)	72 (2.83)	22.2 (.874)	47.6 (1.874)	11 (.433)	17.5 (.69)	31 (1.22)	14.8 (.58)	10.8 (.43)	20 (.79)	19 (.75)	M10 × 35 Lg.	SO-NB-G30	28 (4060)	0.7 (1.5)
F5-08-A-1080	1 BSP.F	55 (2.17)	77 (3.03)	26.2 (1.031)	52.4 (2.063)	11 (.433)	17.5 (.69)	31 (1.22)	14.8 (.58)	10.8 (.43)	21 (.83)	25 (.98)	M10 × 35 Lg.	SO-NB-G35	28 (4060)	0.9 (2.0)
F5-10-A-1080	1-1/4 BSP.F	64 (2.52)	83 (3.27)	30.2 (1.189)	58.7 (2.311)	11 (.433)	17.5 (.69)	39 (1.54)	16.8 (.66)	10.8 (.43)	22 (.87)	32 (1.26)	M10 × 45 Lg.	SO-NB-G40	28 (4060)	1.2 (2.6)
F5-12-A-1080	1-1/2 BSP.F	72 (2.83)	99 (3.90)	35.7 (1.406)	69.9 (2.752)	13.5 (.531)	21 (.83)	41 (1.61)	17.5 (.69)	13.5 (.53)	22 (.87)	38 (1.50)	M12 × 45 Lg.	SO-NB-G50	21 (3050)	1.6 (3.5)
F5-16-A-1080	2 BSP.F	85 (3.35)	107 (4.21)	42.9 (1.689)	77.8 (3.063)	13.5 (.531)	21 (.83)	41 (1.61)	17.5 (.69)	13.5 (.53)	31 (1.22)	50 (1.97)	M12 × 45 Lg.	SO-NB-G65	17.5 (2540)	1.8 (4.0)
F5-20-A-1080	2-1/2 BSP.F	102 (4.02)	118 (4.65)	50.8 (2.000)	88.9 (3.500)	13.5 (.531)	21 (.83)	46 (1.81)	17.5 (.69)	13.5 (.53)	31 (1.22)	63 (2.48)	M12 × 50 Lg.	SO-NB-G75	17.5 (2540)	1.9 (4.2)

★ Approx. mass is the value including socket head cap screws (4 Pcs.).

● Recommended Tightening Torque  
For Socket Head Cap Screw

Kit Numbers	Tightening Torque	
	Recommendation Nm (IN.lbs.)	Tolerance
F5-04-A-1080	35 (310)	±10%
F5-06-A-1080	68.5 (606)	
F5-08-A-1080		
F5-10-A-1080		
F5-12-A-1080	118 (1044)	
F5-16-A-1080		
F5-20-A-1080		

Note: The values of tightening torque above apply to when these flanges are used for pressure line.



■ Socket Welding  
 Japanese Standard "JIS" &  
 European Design Standard : F5- \*-B-10  
 N. American Design Standard : F5- \*-B-1090

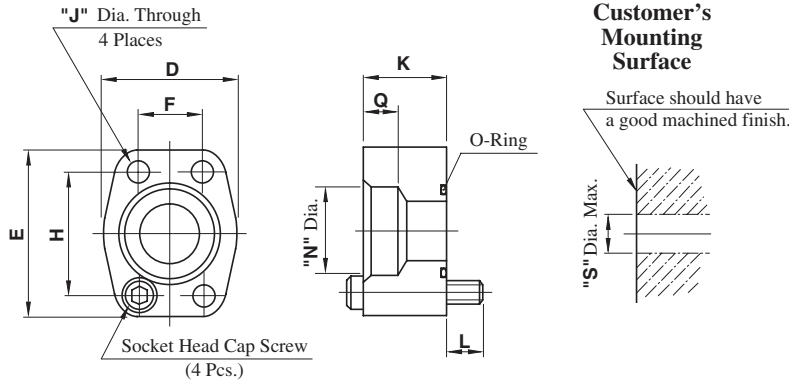

● Recommended Tightening Torque  
 For Socket Head Cap Screw

Kit Numbers	Tightening Torque	
	Recommendation Nm (IN.lbs.)	Tolerance
F5-04W-B F5-04-B F5-06X-B	35 (310)	±10%
F5-06-B F5-08W-B F5-08-B F5-10-B	68.5 (660)	
F5-12-B F5-16W-B F5-16-B F5-20-B	118 (1044)	
F5-24-B F5-28-B F5-32-B	287 (2540)	

Note: The values of tightening torque above apply to when these flanges are used for pressure line.

Kit Numbers	Piping Size	Dimensions mm (Inches)										Socket Head Cap Screw (4 Pcs.)	O-Ring	Max. Operating Pressure MPa(PSI)	Approx. Mass kg (lbs.)	
		D	E	F	H	J	K	L	N	Q	S					
F5-04W-B-10 ----- F5-04W-B-1090	3/8							10 (.39)	17.8 (.701)	9 (.35)				SO-NB-P22	28 (4060)	0.5 (1.1)
F5-04-B-10 ----- F5-04-B-1090	1/2	40 (1.57)	54 (2.13)	17.5 (.689)	38.1 (1.500)	8.8 (.346)	30 (1.18)	10 (.39)	22.2 (.874)	11 (.43)		13 (.51)	M8 × 40 Lg. ----- 5/16-18UNC × 1-3/4 Lg. ----- M8 × 40 Lg. ----- 5/16-18UNC × 1-3/4 Lg.			
F5-06X-B-10 ----- F5-06-B-10 ----- F5-06-B-1090	3/4	48 (1.89)	65 (2.56)	22.2 (.874)	47.6 (1.874)	11 (.433)	30 (1.18)	15 (.59)	27.7 (1.091)	12 (.47)		19 (.75)	M8 × 45 Lg. ----- M10 × 45 Lg. ----- 3/8-16UNC × 1-3/4 Lg.	SO-NB-G30	28 (4060) ----- 14 (2030)	0.7 (1.5)
F5-08W-B-10 ----- F5-08-B-10 ----- F5-08-B-1090	3/4 ----- 1	55 (2.17)	70 (2.76)	26.2 (1.031)	52.4 (2.063)	11 (.433)	30 (1.18)	15 (.59)	27.7 (1.091)	12 (.47)		26 (1.02)	M10 × 45 Lg. ----- 3/8-16UNC × 1-3/4 Lg.	SO-NB-G35	28 (4060) ----- 14 (2030)	0.9 (2.0)
F5-10-B-10 ----- F5-10-B-1090	1-1/4	64 (2.52)	80 (3.15)	30.2 (1.189)	58.7 (2.311)	12 (.472)	38 (1.50)	17 (.67)	43.2 (1.701)	16 (.63)		32 (1.26)	M10 × 55 Lg. ----- 7/16-14UNC × 2-1/4 Lg.	SO-NB-G40	14 (2030)	1.2 (2.7)
F5-12-B-10 ----- F5-12-B-1090	1-1/2	72 (2.83)	94 (3.70)	35.7 (1.406)	69.9 (2.752)	13.5 (.531)	38 (1.50)	17 (.67)	49.1 (1.933)	18 (.71)		38 (1.50)	M12 × 55 Lg. ----- 1/2-13UNC × 2-1/4 Lg.	SO-NB-G50	14 (2030)	1.5 (3.3)
F5-16W-B-10 ----- F5-16W-B-1090	1-1/2	85 (3.35)	102 (4.02)	42.9 (1.689)	77.8 (3.063)	13.5 (.531)	38 (1.50)	17 (.67)	49.1 (1.933)	18 (.71)		48 (1.89)	M12 × 55 Lg. ----- 1/2-13UNC × 2-1/4 Lg.	SO-NB-G60	21 (3050)	1.8 (3.7)
F5-16-B-10 ----- F5-16-B-1090	2							17 (.67)	61.1 (2.406)	20 (.79)		51 (2.01)	M12 × 55 Lg. ----- 1/2-13UNC × 2-1/4 Lg.	SO-NB-G65	10.5 (1520)	1.7 (3.8)
F5-20-B-10 ----- F5-20-B-1090	2-1/2	102 (4.02)	114 (4.49)	50.8 (2.000)	88.9 (3.500)	13.5 (.531)	48 (1.89)	17 (.67)	77.1 (3.035)	22 (.87)		63 (2.48)	M12 × 65 Lg. ----- 1/2-13UNC × 2-3/4 Lg.	SO-NB-G75	7 (1020)	2.0 (4.4)
F5-24-B-10 ----- F5-24-B-1090	3	116 (4.57)	135 (5.31)	61.9 (2.437)	106.4 (4.189)	17.5 (.689)	38 (1.50)	17 (.67)	90.0 (3.543)	25 (.98)		76 (2.99)	M16 × 55 Lg. ----- 5/8-11UNC × 2-1/4 Lg.	SO-NB-G85	3.5 (510)	2.7 (6.0)
F5-28-B-10 ----- F5-28-B-1090	3-1/2	134 (5.28)	153 (6.02)	69.9 (2.752)	120.7 (4.752)	17.5 (.689)	38 (1.50)	17 (.67)	102.8 (4.047)	28 (1.10)		88 (3.46)	M16 × 55 Lg. ----- 5/8-11UNC × 2-1/4 Lg.	SO-NB-G100	3.5 (510)	3.4 (7.5)
F5-32-B-10 ----- F5-32-B-1090	4	150 (5.91)	162 (6.38)	77.8 (2.063)	130.2 (5.126)	17.5 (.689)	38 (1.50)	17 (.67)	115.5 (4.547)	31.5 (1.24)		101 (3.98)	M16 × 55 Lg. ----- 5/8-11UNC × 2-1/4 Lg.	SO-NB-G115	3.5 (510)	3.7 (8.2)

★ Approx. mass is the value including socket head cap screws (4 Pcs.).

**■ Butt Welding**

Japanese Standard "JIS" & European Design Standard : F5- \*-C-10

N. American Design Standard : F5- \*-C-1090

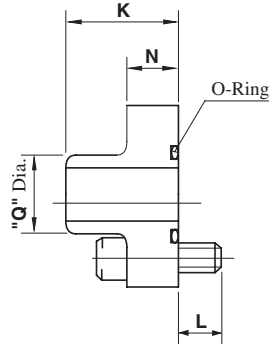
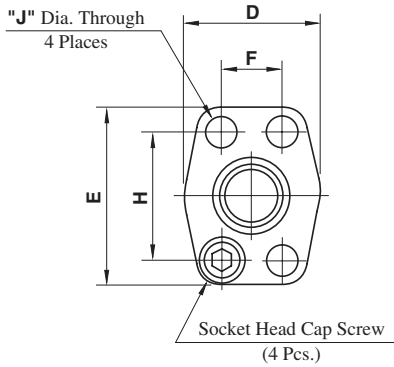

**Customer's  
Mounting Surface**

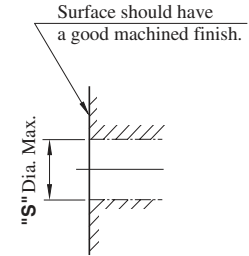

Kit Numbers	Piping Size	Dimensions mm (Inches)										Socket Head Cap Screw (4 Pcs.)	O-Ring	Max. Operating Pressure MPa (PSI)	Approx.* Mass kg (lbs.)
		D	E	F	H	J	K	L	N	Q	S				
F5-04-C-10 ----- F5-04-C-1090	1/2	40 (1.57)	54 (2.13)	17.5 (.689)	38.1 (1.500)	8.8 (.346)	39 (1.54)	13 (.51) 14.8 (.58)	17 (.67)	21.7 (.85)	13 (.51)	M8 × 30 Lg. ----- 5/16-18UNC × 1-1/4 Lg.	SO-NB-P22	28 (4060)	0.25 (.6)
F5-06-C-10 ----- F5-06-C-1090	3/4	48 (1.89)	65 (2.56)	22.2 (.874)	47.6 (1.874)	11 (.433)	41 (1.61)	16 (.63) 19.1 (.75)	19 (.75)	27.2 (1.07)	19 (.75)	M10 × 35 Lg. ----- 3/8-16UNC × 1-1/2 Lg.	SO-NB-G30	28 (4060)	0.35 (.8)
F5-08-C-10 ----- F5-08-C-1090	1	55 (2.17)	70 (2.76)	26.2 (1.031)	52.4 (2.063)	11 (.433)	42 (1.65)	16 (.63) 19.1 (.75)	19 (.75)	34 (1.34)	26 (1.02)	M10 × 35 Lg. ----- 3/8-16UNC × 1-1/2 Lg.	SO-NB-G35	28 (4060)	0.45 (1.0)
F5-10-C-10 ----- F5-10-C-1090	1-1/4	64 (2.52)	80 (3.15)	30.2 (1.189)	58.7 (2.311)	11 (.433) 12 (.472)	44 (1.73)	16 (.63) 19.1 (.75)	19 (.75)	42.7 (1.68)	32 (1.26)	M10 × 35 Lg. ----- 7/16-14UNC × 1-1/2 Lg.	SO-NB-G40	28 (4060)	0.63 (1.4)
F5-12-C-10 ----- F5-12-C-1090	1-1/2	72 (2.83)	94 (3.70)	35.7 (1.406)	69.9 (2.752)	13.5 (.531)	50 (1.97)	18 (.71) 16.1 (.63)	22 (.87)	48.6 (1.91)	38 (1.50)	M12 × 40 Lg. ----- 1/2-13UNC × 1-1/2 Lg.	SO-NB-G50	21 (3050)	1.3 (2.9)
F5-16-C-10 ----- F5-16-C-1090	2	85 (3.35)	102 (4.02)	42.9 (1.689)	77.8 (3.063)	13.5 (.531)	50 (1.97)	18 (.71) 16.1 (.63)	22 (.87)	60.5 (2.38)	51 (2.01)	M12 × 40 Lg. ----- 1/2-13UNC × 1-1/2 Lg.	SO-NB-G65	17.5 (2540)	1.3 (2.9)
F5-20-C-10 ----- F5-20-C-1090	2-1/2	102 (4.02)	114 (4.49)	50.8 (2.000)	88.9 (3.500)	13.5 (.531)	50 (1.97)	20 (.79) 19.5 (.77)	25 (.98)	76.3 (3.00)	63 (2.48)	M12 × 45 Lg. ----- 1/2-13UNC × 1-3/4 Lg.	SO-NB-G75	14 (2030)	1.4 (3.1)

★ Approx. mass is the value including socket head cap screws (4 Pcs.).

**● Recommended Tightening Torque  
For Socket Head Cap Screw**

Kit Numbers	Tightening Torque	
	Recommendation Nm (IN.lbs.)	Tolerance
F5-04-C	35 (310)	±10%
F5-06-C	68.5 (660)	
F5-08-C		
F5-10-C		
F5-12-C	118 (1044)	
F5-16-C		
F5-20-C		

Note: The values of tightening torque above apply to when these flanges are used for pressure line.

## “F6” Series Pipe Flange Kits

The dimensions of the flange mounting surface are based upon SAE 4 Bolt Split Flange (High Pressure Series).

### Specifications

Model Numbers	Max. Operating Pressure MPa (PSI)	Remarks
F6-*A-*-10/1080/1090	31 (4500)	Threaded Connection
F6-*-B-*-10/1090	42 (6090)	Pipe Socket Welding

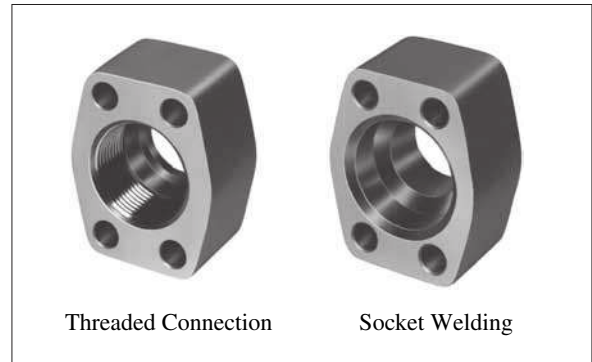

### Model Number Designation

F-	F6	-06	-A	-M	-10	*		
Material of Seal	Series Number	Flange Size	Type of Pipe Connection	Type of Mounting Bolt	Design Number	Design Standards		
<b>None:</b> Standard NBR (Buna N) Seal  <b>F:</b> FPM (Viton) Seal (For Synthetic Fluids)	F6	04W, 04 06W, 06 08W, 08 10W, 10 12W, 12	A: Threaded Connection	M: Metric Thd.	10	None: Japanese Standard "JIS"		
		04W, 04 06W, 06 08W, 08 10W, 10 12W, 12		M: Metric Thd.		80: European Design Standard		
		04W, 04 06W, 06 08W, 08 10W, 10 12W, 12		U: Unified Thd.		90: N. American Design Standard		
		04W, 04 06W, 06 08W, 08 10W, 10 12W, 12		B: Pipe Socket Welding		M: Metric Thd.	10	None: Japanese Standard "JIS" & European Design Standard
		04W, 04 06W, 06 08W, 08 10W, 10 12W, 12				U: Unified Thd.		90: N. American Design Standard

★ Three different design standards are available as shown below. Select the suitable design standard to your requirement.

Type of Pipe Connection	Design Standard	Pipe Thread	Mounting Bolt (Socket Head Cap Screw)
Threaded Connection	Japanese Standard "JIS"	Rc	Metric Thd.
	European Design Standard	BSP.F	Metric Thd.
	N. American Design Standard	NPT	Unified Thd.
Pipe Socket Welding	Japanese Standard "JIS" & European Design Standard	—	Metric Thd.
	N. American Design Standard	—	Unified Thd.

■ Threaded Connection

Japanese Standard "JIS" : F6-*\**-A-M-10  
 N. American Design Standard : F6-*\**-A-U-1090

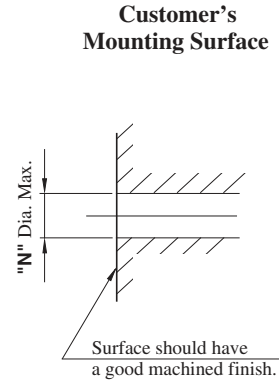
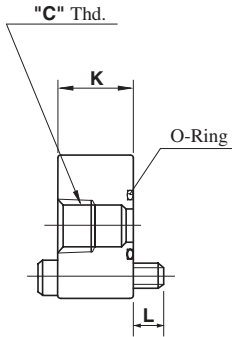
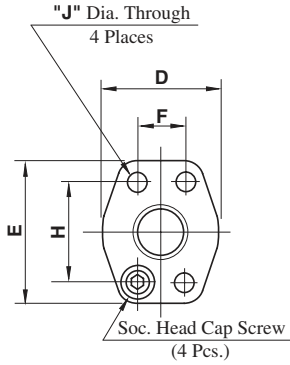

Kit Numbers	Piping Size "C" Thd.	Dimensions mm (Inches)								Socket Head Cap Screw (4 Pcs.)	O-Ring	Approx. <sup>*1</sup> Mass kg (lbs.)	Recommended <sup>*2</sup> Tightening Torque (Tolerance ±10%) Nm (IN.lbs.)
		D	E	F	H	J	K	L	N				
F6-04W-A-M-10	Rc 3/8	48 (1.89)	56.5 (2.22)	18.2 (.717)	40.5 (1.594)	8.8 (.346)	28 (1.10)	12 (.47)	15 (.59)	M8 × 40 Lg	SO-NB-P22	0.4 (.9)	35 (310)
F6-04-A-M-10	Rc 1/2												
F6-04W-A-U-1090	3/8 NPT						26 (1.02)	12.1 (.48)		5/16-18UNC × 1-1/2 Lg			
F6-04-A-U-1090	1/2 NPT												
F6-06W-A-M-10	Rc 1/2	57.5 (2.26)	77.5 (3.05)	23.8 (.937)	50.8 (2.000)	11 (.433)	30	15 (.59)	21 (.83)	M10 × 45 Lg	SO-NB-G30	0.9 (2.0)	68.5 (606)
F6-06-A-M-10	Rc 3/4												
F6-06W-A-U-1090	1/2 NPT						14.5 (.57)	3/8-16UNC × 1-3/4 Lg					
F6-06-A-U-1090	3/4 NPT												
F6-08W-A-M-10	Rc 3/4	65 (2.56)	81 (3.19)	27.8 (1.094)	57.2 (2.252)	13.5 (.531)	30 (1.18)	15 (.59)	26 (1.02)	M12 × 45 Lg.	SO-NB-G35	1.1 (2.4)	118 (1044)
F6-08-A-M-10	Rc 1												
F6-08W-A-U-1090	3/4 NPT						26.5 (1.04)	18 (.71)		7/16-14UNC × 1-3/4 Lg.			
F6-08-A-U-1090	1 NPT						34 (1.34)	16.8 (.66)		7/16-14UNC × 2 Lg.			
F6-10W-A-M-10	Rc 1	72 (2.83)	95 (3.74)	31.8 (1.252)	66.7 (2.626)	13.5 (.531)	34 (1.34)	16 (.63)	34 (1.34)	M12 × 50 Lg.	SO-NB-G40	1.3 (2.9)	118 (1044)
F6-10-A-M-10	Rc 1-1/4												
F6-10W-A-U-1090	1 NPT						34 (1.34)	16.8 (.66)		1/2-13UNC × 2 Lg.			
F6-10-A-U-1090	1-1/4 NPT						39 (1.54)	18.2 (.72)		1/2-13UNC × 2-1/4 Lg.			
F6-12W-A-M-10	Rc 1-1/4	90 (3.54)	113 (4.45)	36.5 (1.437)	79.4 (3.126)	17.5 (.689)	34 (1.34)	21 (.83)	44 (1.73)	M16 × 55 Lg.	SO-NB-G50	1.5 (3.3)	287 (2540)
F6-12-A-M-10	Rc 1-1/2												
F6-12W-A-U-1090	1-1/4 NPT						34 (1.34)	23.2 (.91)		5/8-11UNC × 2-1/4 Lg.			
F6-12-A-U-1090	1-1/2 NPT						39 (1.54)	24.5 (.96)		5/8-11UNC × 2-1/2 Lg.			

★1. Approx. mass is the value including socket head cap screws (4 Pcs.).

★2. The values of recommended tightening torque are for socket head cap screws.

■ Threaded Connection

European Design Standard : F6- \*-A-M-1080

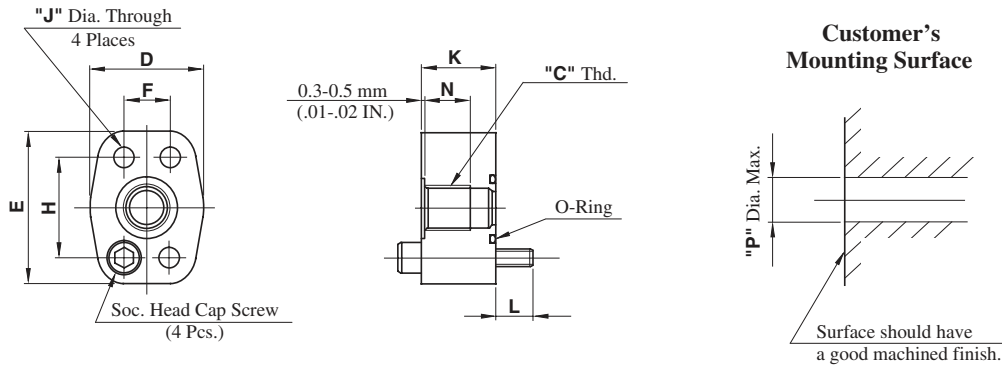

Kit Numbers	Piping Size "C" Thd.	Dimensions mm (Inches)										Socket Head Cap Screw (4 Pcs.)	O-Ring	Approx. Mass kg (lbs.) <sup>*1</sup>	Recommended Tightening Torque (Tolerance ±10%) Nm (IN.lbs.) <sup>*2</sup>
		D	E	F	H	J	K	L	N	P					
F6-04W-A-M-1080	3/8 BSP.F	48 (1.89)	56.5 (2.22)	18.2 (.717)	40.5 (1.594)	8.8 (.346)	28 (1.10)	12 (.47)	14 (.55)	15 (.59)		M8 × 40 Lg.	SO-NB-P22	0.4 (.9)	35 (310)
F6-04-A-M-1080	1/2 BSP.F								17 (.67)						
F6-06W-A-M-1080	1/2 BSP.F	57.5 (2.26)	77.5 (3.05)	23.8 (.937)	50.8 (2.000)	11 (.433)	30 (1.18)	15 (.59)	17 (.67)	21 (.83)		M10 × 45 Lg.	SO-NB-G30	0.9 (2.0)	68.5 (606)
F6-06-A-M-1080	3/4 BSP.F								20 (.79)						
F6-08W-A-M-1080	3/4 BSP.F	65 (2.56)	81 (3.19)	27.8 (1.094)	57.2 (2.252)	13.5 (.531)	30 (1.18)	15 (.59)	20 (.79)	26 (1.02)		M12 × 45 Lg.	SO-NB-G35	1.1 (2.4)	118 (1044)
F6-08-A-M-1080	1 BSP.F						34 (1.34)	16 (.63)	21 (.83)		M12 × 50 Lg.				
F6-10W-A-M-1080	1 BSP.F	72 (2.83)	95 (3.74)	31.8 (1.252)	66.7 (2.626)	13.5 (.531)	34 (1.34)	16 (.63)	21 (.83)	34 (1.34)		M12 × 50 Lg.	SO-NB-G40	1.3 (2.9)	118 (1044)
F6-10-A-M-1080	1-1/4 BSP.F						39 (1.54)	22 (.87)			M12 × 55 Lg.				
F6-12W-A-M-1080	1-1/4 BSP.F	90 (3.54)	113 (4.45)	36.5 (1.437)	79.4 (3.126)	17.5 (.689)	34 (1.34)	21 (.83)	22 (.87)	44 (1.73)		M16 × 55 Lg.	SO-NB-G50	1.5 (3.3)	287 (2540)
F6-12-A-M-1080	1-1/2 BSP.F						39 (1.54)				M16 × 60 Lg.				

★1. Approx. mass is the value including socket head cap screws (4 Pcs.).

★2. The values of recommended tightening torque are for socket head cap screw.

■ Socket Welding

Japanese Standard "JIS" & European Design Standard : F6- \*-B-M-10  
 N. American Design Standard : F6- \*-B-U-1090

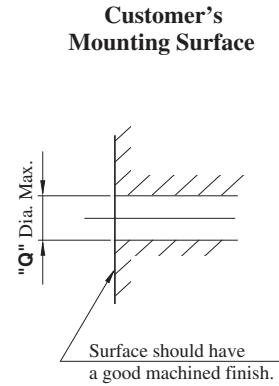
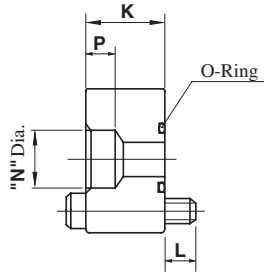
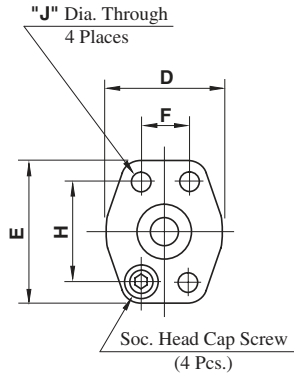

Kit Numbers	Piping Size	Dimensions mm (Inches)										Socket Head Cap Screw (4 Pcs.)	O-Ring	Approx. Mass kg (lbs.) <sup>*1</sup>	Recommended Tightening Torque (Tolerance ±10%) Nm (IN.lbs.) <sup>*2</sup>
		D	E	F	H	J	K	L	N	P	Q				
F6-04W-B-M-10	3/8						28 (1.10)	12 (.47)	17.8 (.701)	9 (.35)	15 (.59)	M8 × 40 Lg.	SO-NB-P22	0.4 (.9)	35 (310)
F6-04W-B-U-1090							26 (1.02)	12.1 (.48)				5/16-18UNC × 1-1/2 Lg.			
F6-04-B-M-10	1/2						28 (1.10)	12 (.47)	22.2 (.874)	11 (.43)	M8 × 40 Lg.				
F6-04-B-U-1090							26 (1.02)	12.1 (.48)			5/16-18UNC × 1-1/2 Lg.				
F6-06W-B-M-10	1/2							15 (.59)	22.2 (.874)	11 (.43)	21 (.83)	M10 × 45 Lg.	SO-NB-G30	0.9 (2.0)	68.5 (606)
F6-06W-B-U-1090							30 (1.18)	14.5 (.57)				3/8-16UNC × 1-3/4 Lg.			
F6-06-B-M-10	3/4						15 (.59)	27.7 (1.091)	12 (.47)	14 (.55)	M10 × 45 Lg.				
F6-06-B-U-1090							30 (1.18)	14.5 (.57)			3/8-16UNC × 1-3/4 Lg.				
F6-08W-B-M-10	3/4						30 (1.18)	15 (.59)	27.7 (1.091)	12 (.47)	26 (1.02)	M12 × 45 Lg.	SO-NB-G35	1.1 (2.4)	118 (1044)
F6-08W-B-U-1090							26.5 (1.04)	18 (.71)				7/16-14UNC × 1-3/4 Lg.			
F6-08-B-M-10	1						30 (1.18)	15 (.59)	34.5 (1.358)	14 (.55)	34 (1.34)	M12 × 45 Lg.			
F6-08-B-U-1090							26.5 (1.04)	18 (.71)				7/16-14UNC × 1-3/4 Lg.			
F6-10W-B-M-10	1							16 (.63)	34.5 (1.358)	14 (.55)	34 (1.34)	M12 × 50 Lg.	SO-NB-G40	1.3 (2.9)	118 (1044)
F6-10W-B-U-1090							34 (1.34)	16.8 (.66)				1/2-13UNC × 2 Lg.			
F6-10-B-M-10	1-1/4						16 (.63)	43.2 (1.701)	16 (.63)	16 (.63)	44 (1.73)	M12 × 50 Lg.			
F6-10-B-U-1090							34 (1.34)	16.8 (.66)				1/2-13UNC × 2 Lg.			
F6-12W-B-M-10	1-1/4							21 (.83)	43.2 (1.701)	16 (.63)	44 (1.73)	M16 × 55 Lg.	SO-NB-G50	1.5 (3.3)	287 (2540)
F6-12W-B-U-1090							34 (1.34)	23.2 (.91)				5/8-11UNC × 2-1/4 Lg.			
F6-12-B-M-10	1-1/2						21 (.83)	49.1 (1.933)	18 (.71)	18 (.71)	44 (1.73)	M16 × 55 Lg.			
F6-12-B-U-1090							34 (1.34)	23.2 (.91)				5/8-11UNC × 2-1/4 Lg.			

★ 1. Approx. mass is the value including socket head cap screws (4 Pcs.).  
 ★ 2. The values of recommended tightening torque are for socket head cap screws.

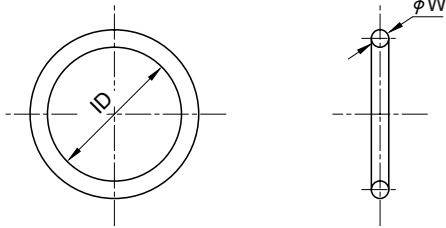

### O-ring Symbol

**SO - N A - P 90**

- Size
- Classification by use
  - P:** For Moving (Packing)
  - G:** For Fixing (Gasket)
- Durometer
  - A:** A70
  - B:** A90
- Material
  - N:** Nitrile Rubber (NBR)
  - F:** Fluororubber (FPM)
- O-Ring

SO-NA/NB-P*		SO-FA/FB-P*	
Size Number	Dimensions mm (Inches)		
	ID	W	
P 3	2.8 ( .110 )	1.9 (.075)	
P 4	3.8 ( .150 )		
P 5	4.8 ( .189 )		
P 6	5.8 ( .228 )		
P 7	6.8 ( .268 )		
P 8	7.8 ( .307 )		
P 9	8.8 ( .346 )		
P 10	9.8 ( .386 )		
P 10A	9.8 ( .386 )		
P 11	10.8 ( .425 )		
P 11.2	11.0 ( .433 )	2.4 (.094)	
P 12	11.8 ( .465 )		
P 12.5	12.3 ( .484 )		
P 14	13.8 ( .543 )		
P 15	14.8 ( .583 )		
P 16	15.8 ( .622 )		
P 18	17.8 ( .701 )		
P 20	19.8 ( .780 )		
P 21	20.8 ( .819 )		
P 22	21.8 ( .858 )		
P 22A	21.7 ( .854 )	3.5 (.138)	
P 22.4	22.1 ( .870 )		
P 24	23.7 ( .933 )		
P 25	24.7 ( .972 )		
P 25.5	25.2 ( .992 )		
P 26	25.7 ( 1.012 )		
P 28	27.7 ( 1.091 )		
P 29	28.7 ( 1.130 )		
P 29.5	29.2 ( 1.150 )		
P 30	29.7 ( 1.169 )		
P 31	30.7 ( 1.209 )	5.7 (.224)	
P 31.5	31.2 ( 1.228 )		
P 32	31.7 ( 1.248 )		
P 34	33.7 ( 1.327 )		
P 35	34.7 ( 1.366 )		
P 35.5	35.2 ( 1.386 )		
P 36	35.7 ( 1.406 )		
P 38	37.7 ( 1.484 )		
P 39	38.7 ( 1.524 )		
P 40	39.7 ( 1.563 )		
P 41	40.7 ( 1.602 )	8.4 (.331)	
P 42	41.7 ( 1.642 )		
P 44	43.7 ( 1.720 )		
P 45	44.7 ( 1.760 )		
P 46	45.7 ( 1.799 )		
P 48	47.7 ( 1.878 )		
P 49	48.7 ( 1.917 )		
P 50	49.7 ( 1.957 )		
P 48A	47.6 ( 1.874 )		
P 50A	49.6 ( 1.953 )		
P 52	51.6 ( 2.031 )	5.7 (.224)	
P 53	52.6 ( 2.071 )		
P 55	54.6 ( 2.150 )		
P 56	55.6 ( 2.189 )		
P 58	57.6 ( 2.268 )		
P 60	59.6 ( 2.346 )		
P 62	61.6 ( 2.425 )		
P 63	62.6 ( 2.465 )		
P 65	64.6 ( 2.543 )		
P 67	66.6 ( 2.622 )		
P 70	69.6 ( 2.740 )	8.4 (.331)	
P 71	70.6 ( 2.780 )		
P 75	74.6 ( 2.937 )		
P 80	79.6 ( 3.134 )		
P 85	84.6 ( 3.331 )		

SO-NA/NB-P*		SO-FA/FB-P*	
Size Number	Dimensions mm (Inches)		
	ID	W	
P 90	89.6 ( 3.528 )	5.7 (.224)	
P 95	94.6 ( 3.724 )		
P100	99.6 ( 3.921 )		
P102	101.6 ( 4.000 )		
P105	104.6 ( 4.118 )		
P110	109.6 ( 4.315 )		
P112	111.6 ( 4.394 )		
P115	114.6 ( 4.512 )		
P120	119.6 ( 4.709 )		
P125	124.6 ( 4.906 )		
P130	129.6 ( 5.102 )	8.4 (.331)	
P132	131.6 ( 5.181 )		
P135	134.6 ( 5.299 )		
P140	139.6 ( 5.496 )		
P145	144.6 ( 5.693 )		
P150	149.6 ( 5.890 )		
P150A	149.5 ( 5.886 )		
P155	154.5 ( 6.083 )		
P160	159.5 ( 6.280 )		
P165	164.5 ( 6.476 )		
P170	169.5 ( 6.673 )		
P175	174.5 ( 6.870 )	5.7 (.224)	
P180	179.5 ( 7.067 )		
P185	184.5 ( 7.264 )		
P190	189.5 ( 7.461 )		
P195	194.5 ( 7.657 )		
P200	199.5 ( 7.854 )		
P205	204.5 ( 8.051 )		
P209	208.5 ( 8.209 )		
P210	209.5 ( 8.248 )		
P215	214.5 ( 8.445 )		
P220	219.5 ( 8.642 )		
P225	224.5 ( 8.839 )	8.4 (.331)	
P230	229.5 ( 9.035 )		
P235	234.5 ( 9.232 )		
P240	239.5 ( 9.429 )		
P245	244.5 ( 9.626 )		
P250	249.5 ( 9.823 )		
P255	254.5 ( 10.020 )		
P260	259.5 ( 10.217 )		
P265	264.5 ( 10.413 )		
P270	269.5 ( 10.610 )		
P275	274.5 ( 10.807 )	5.7 (.224)	
P280	279.5 ( 11.004 )		
P285	284.5 ( 11.201 )		
P290	289.5 ( 11.398 )		
P295	294.5 ( 11.594 )		
P300	299.5 ( 11.791 )		
P315	314.5 ( 12.382 )		
P320	319.5 ( 12.579 )		
P335	334.5 ( 13.169 )		
P340	339.5 ( 13.366 )		
P355	354.5 ( 13.957 )	8.4 (.331)	
P360	359.5 ( 14.154 )		
P375	374.5 ( 14.744 )		
P385	384.5 ( 15.138 )		
P400	399.5 ( 15.728 )		

SO-NA/NB-G*		SO-FA/FB-G*	
Size Number	Dimensions mm (Inches)		
	ID	W	
G 25	24.4 ( .961 )	3.1 (.122)	
G 30	29.4 ( 1.157 )		
G 35	34.4 ( 1.354 )		
G 40	39.4 ( 1.551 )		
G 45	44.4 ( 1.748 )		
G 50	49.4 ( 1.945 )		
G 55	54.4 ( 2.142 )		
G 60	59.4 ( 2.339 )		
G 65	64.4 ( 2.535 )		
G 70	69.4 ( 2.732 )		
G 75	74.4 ( 2.929 )	5.7 (.224)	
G 80	79.4 ( 3.126 )		
G 85	84.4 ( 3.323 )		
G 90	89.4 ( 3.520 )		
G 95	94.4 ( 3.717 )		
G100	99.4 ( 3.913 )		
G105	104.4 ( 4.110 )		
G110	109.4 ( 4.307 )		
G115	114.4 ( 4.504 )		
G120	119.4 ( 4.701 )		
G125	124.4 ( 4.898 )	8.4 (.331)	
G130	129.4 ( 5.094 )		
G135	134.4 ( 5.291 )		
G140	139.4 ( 5.488 )		
G145	144.4 ( 5.685 )		
G150	149.3 ( 5.878 )		
G155	154.3 ( 6.075 )		
G160	159.3 ( 6.272 )		
G165	164.3 ( 6.469 )		
G170	169.3 ( 6.665 )		
G175	174.3 ( 6.862 )	5.7 (.224)	
G180	179.3 ( 7.059 )		
G185	184.3 ( 7.256 )		
G190	189.3 ( 7.453 )		
G195	194.3 ( 7.650 )		
G200	199.3 ( 7.846 )		
G210	209.3 ( 8.240 )		
G220	219.3 ( 8.634 )		
G230	229.3 ( 9.028 )		
G240	239.3 ( 9.421 )		
G250	249.3 ( 9.815 )	8.4 (.331)	
G260	259.3 ( 10.209 )		
G270	269.3 ( 10.602 )		
G280	279.3 ( 10.996 )		
G290	289.3 ( 11.390 )		
G300	299.3 ( 11.783 )		

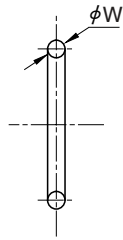
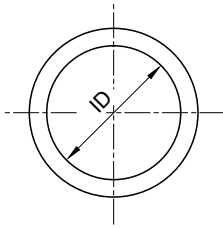

### O-ring Symbol

SO - N A - A 012

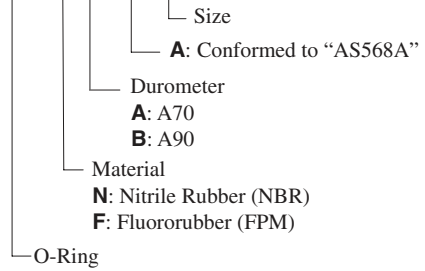

Size Number	Dimensions mm (Inches)	
	ID	W
A006	2.90 (.114)	
A007	3.68 (.145)	
A008	4.47 (.176)	
A009	5.28 (.208)	
A010	6.07 (.239)	
A011	7.65 (.301)	
A012	9.25 (.364)	
A013	10.82 (.426)	
A014	12.42 (.489)	
A015	14.00 (.551)	
A016	15.60 (.614)	
A017	17.17 (.676)	
A018	18.77 (.739)	
A019	20.35 (.801)	
A020	21.95 (.864)	
A021	23.52 (.926)	
A022	25.12 (.989)	
A023	26.70 (1.051)	
A024	28.30 (1.114)	
A025	29.87 (1.176)	
A026	31.47 (1.239)	
A027	33.05 (1.301)	
A028	34.65 (1.364)	
A029	37.82 (1.489)	
A030	41.00 (1.614)	
A031	44.17 (1.739)	
A032	47.35 (1.864)	
A033	50.52 (1.989)	
A034	53.70 (2.114)	
A035	56.87 (2.239)	
A036	60.05 (2.364)	
A037	63.22 (2.489)	
A038	66.40 (2.614)	
A039	69.57 (2.739)	
A040	72.75 (2.864)	
A041	75.92 (2.989)	
A042	82.27 (3.239)	
A043	88.62 (3.489)	
A044	94.97 (3.739)	
A045	101.32 (3.989)	
A046	107.67 (4.239)	
A047	114.02 (4.489)	
A048	120.37 (4.739)	
A049	126.72 (4.989)	
A050	133.07 (5.239)	
A110	9.19 (.362)	
A111	10.77 (.424)	
A112	12.37 (.487)	
A113	13.94 (.549)	
A114	15.54 (.612)	
A115	17.12 (.674)	
A116	18.72 (.737)	
A117	20.29 (.799)	
A118	21.89 (.862)	
A119	23.47 (.924)	
A120	25.07 (.987)	
A121	26.64 (1.049)	
A122	28.24 (1.112)	
A123	29.82 (1.174)	
A124	31.42 (1.237)	
A125	32.99 (1.299)	
A126	34.59 (1.362)	
A127	36.17 (1.424)	
A128	37.77 (1.487)	
A129	39.34 (1.549)	
A130	40.94 (1.612)	
A131	42.52 (1.674)	
A132	44.12 (1.737)	
A133	45.69 (1.799)	
A134	47.29 (1.862)	

1.78 (.070)

2.62 (.103)

Size Number	Dimensions mm (Inches)	
	ID	W
A135	48.90 (1.925)	
A136	50.47 (1.987)	
A137	52.07 (2.050)	
A138	53.64 (2.112)	
A139	55.24 (2.175)	
A140	56.82 (2.237)	
A141	58.42 (2.300)	
A142	59.99 (2.362)	
A143	61.60 (2.425)	
A144	63.17 (2.487)	
A145	64.77 (2.550)	
A146	66.34 (2.612)	
A147	67.94 (2.675)	
A148	69.52 (2.737)	
A149	71.12 (2.800)	
A150	72.69 (2.862)	
A151	75.87 (2.987)	
A152	82.22 (3.237)	
A153	88.57 (3.487)	
A154	94.92 (3.737)	
A155	101.27 (3.987)	
A156	107.62 (4.237)	
A157	113.97 (4.487)	
A158	120.32 (4.737)	
A159	126.67 (4.987)	
A160	133.02 (5.237)	
A161	139.37 (5.487)	
A162	145.72 (5.737)	
A163	152.07 (5.987)	
A164	158.42 (6.237)	
A165	164.77 (6.487)	
A166	171.12 (6.737)	
A167	177.47 (6.987)	
A168	183.82 (7.237)	
A169	190.17 (7.487)	
A170	196.52 (7.737)	
A171	202.87 (7.987)	
A172	209.22 (8.237)	
A173	215.57 (8.487)	
A174	221.92 (8.737)	
A175	228.27 (8.987)	
A176	234.62 (9.237)	
A177	240.97 (9.487)	
A178	247.32 (9.737)	
A210	18.64 (.734)	
A211	20.22 (.796)	
A212	21.82 (.859)	
A213	23.39 (.921)	
A214	24.99 (.984)	
A215	26.57 (1.046)	
A216	28.17 (1.109)	
A217	29.74 (1.171)	
A218	31.34 (1.234)	
A219	32.92 (1.296)	
A220	34.52 (1.359)	
A221	36.09 (1.421)	
A222	37.69 (1.484)	
A223	40.87 (1.609)	
A224	44.04 (1.734)	
A225	47.22 (1.859)	
A226	50.39 (1.984)	
A227	53.57 (2.109)	
A228	56.74 (2.234)	
A229	59.92 (2.359)	

2.62 (.103)

3.53 (.139)

Size Number	Dimensions mm (Inches)	
	ID	W
A230	63.09 (2.484)	
A231	66.27 (2.609)	
A232	69.44 (2.734)	
A233	72.62 (2.859)	
A234	75.79 (2.984)	
A235	78.97 (3.109)	
A236	82.14 (3.234)	
A237	85.32 (3.359)	
A238	88.49 (3.484)	
A239	91.67 (3.609)	
A240	94.84 (3.734)	
A241	98.02 (3.859)	
A242	101.19 (3.984)	
A243	104.37 (4.109)	
A244	107.54 (4.234)	
A245	110.72 (4.359)	
A246	113.89 (4.484)	
A247	117.07 (4.609)	
A248	120.24 (4.734)	
A249	123.42 (4.859)	
A250	126.59 (4.984)	
A251	129.77 (5.109)	
A252	132.94 (5.234)	
A253	136.12 (5.359)	
A254	139.29 (5.484)	
A255	142.47 (5.609)	
A256	145.64 (5.734)	
A257	148.82 (5.859)	
A258	151.99 (5.984)	
A259	155.17 (6.109)	
A260	164.69 (6.484)	
A261	171.04 (6.734)	
A262	177.39 (6.984)	
A263	183.74 (7.234)	
A264	190.09 (7.484)	
A265	196.44 (7.734)	
A266	202.79 (7.984)	
A267	209.14 (8.234)	
A268	215.49 (8.484)	
A269	221.84 (8.734)	
A270	228.19 (8.984)	
A271	234.54 (9.234)	
A272	240.89 (9.484)	
A273	247.24 (9.734)	
A274	253.59 (9.984)	
A901	4.70 (.185)	1.42 (.056)
A902	6.07 (.239)	1.63 (.064)
A903	7.64 (.301)	1.63 (.064)
A904	8.92 (.351)	1.83 (.072)
A905	10.52 (.414)	1.83 (.072)
A906	11.89 (.468)	1.98 (.078)
A907	13.46 (.530)	2.08 (.082)
A908	16.36 (.644)	2.21 (.087)
A909	17.93 (.706)	2.46 (.097)
A910	19.18 (.755)	2.46 (.097)
A911	21.92 (.863)	
A912	23.47 (.924)	
A913	25.04 (.986)	
A914	26.59 (1.047)	2.95 (.116)
A916	29.74 (1.171)	
A918	34.42 (1.355)	
A920	37.46 (1.475)	
A924	43.69 (1.720)	3.00 (.118)
A928	53.09 (2.090)	
A932	59.36 (2.337)	

3.53 (.139)



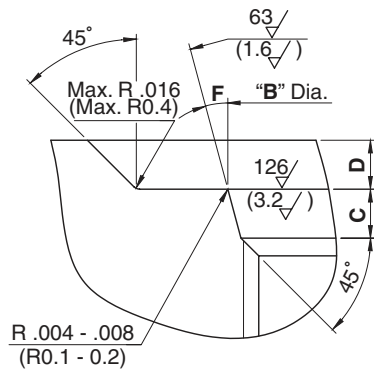

Detail "X"

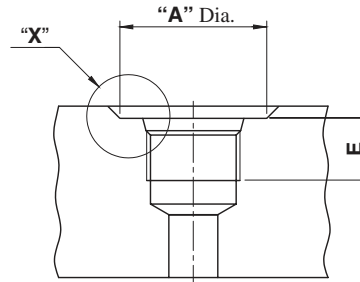

DIMENSIONS IN  
 INCHES (MILLIMETRES)

Nominal Tube OD		Thread Size	Dimensions Inch (mm)						O-Ring Size (Hs 90)
			A*	B	C	D	E	F	
Dash Size	Inch		(Min.)	±.002 (±0.05)	+0.15 0 (+0.4 0)	(Max.)	(Min.)	±1°	
-2	1/8	5/16-24 UNF-2B	.669 (17)	.360 (9.15)	.075 (1.9)	.063 (1.6)	.394 (10)	12	AS568-902
-3	3/16	3/8-24 UNF-2B	.748 (19)	.423 (10.75)	.075 (1.9)	.063 (1.6)	.394 (10)	12	AS568-903
-4	1/4	7/16-20 UNF-2B	.827 (21)	.490 (12.45)	.094 (2.4)	.063 (1.6)	.453 (11.5)	12	AS568-904
-5	5/16	1/2-20 UNF-2B	.906 (23)	.553 (14.05)	.094 (2.4)	.063 (1.6)	.453 (11.5)	12	AS568-905
-6	3/8	9/16-18 UNF-2B	.984 (25)	.618 (15.7)	.098 (2.5)	.063 (1.6)	.453 (11.5)	12	AS568-906
-8	1/2	3/4-16 UNF-2B	1.181 (30)	.813 (20.65)	.098 (2.5)	.095 (2.4)	.500 (12.7)	15	AS568-908
-10	5/8	7/8-14 UNF-2B	1.339 (34)	.945 (24)	.098 (2.5)	.095 (2.4)	.563 (14.3)	15	AS568-910
-12	3/4	1-1/16-12 UN-2B	1.614 (41)	1.150 (29.2)	.130 (3.3)	.095 (2.4)	.657 (16.7)	15	AS568-912
-14	7/8	1-3/16-12 UN-2B	1.772 (45)	1.276 (32.4)	.130 (3.3)	.095 (2.4)	.748 (19)	15	AS568-914
-16	1	1-5/16-12 UN-2B	1.929 (49)	1.400 (35.55)	.130 (3.3)	.126 (3.2)	.748 (19)	15	AS568-916
-20	1-1/4	1-5/8-12 UN-2B	2.283 (58)	1.715 (43.55)	.130 (3.3)	.126 (3.2)	.748 (19)	15	AS568-920
-24	1-1/2	1-7/8-12 UN-2B	2.559 (65)	1.965 (49.9)	.130 (3.3)	.126 (3.2)	.748 (19)	15	AS568-924
-32	2	2-1/2-12 UN-2B	3.465 (88)	2.589 (65.75)	.130 (3.3)	.126 (3.2)	.748 (19)	15	AS568-932

★ If face of boss is on a machined surface, dimensions "A" and "D" need not apply as long as corner radius R .0004 - .0008 inches (R 0.1 - 0.2 mm) is maintained.