

## ■ Power Amplifiers For 40Ω - 10Ω Series Control Valves

These power amplifiers are specially designed to combine and incorporate the functions of pressure control (10Ω solenoid) and flow control (40Ω solenoid) into one and can be used for the proportional electro-hydraulic flow control and relief valves of which model numbers are as shown below.



### ■ Model Number Designation

AME	-D2	-H1	-100	-12
Series Number	Type of Function	Type of Mounting	Power Supply	Design Number
AME	D2: DC Input Type	H1: Wall Tapestry Type	100: 100 V AC 200: 200/220 V AC	12

### ■ Applicable to Valve

Name of Valve	Model Numbers
40Ω - 10Ω Series Flow Control and Relief Valve	EFBG-03-125-C/H-17* EFBG-06-250-C/H-17* EFBG-10-500-C/H-17*

### ■ Specifications

Description	Model No. AME-D2-H1-*12	
	Flow Controls (40Ω Solenoid)	Pressure Controls (10Ω Solenoid)
Type of Function	DC Input Type	DC Input Type
Max. Output Current	0.8 A (40Ω Solenoid)	1 A (10Ω Solenoid)
Max. Input Voltage	+10 V DC	+10 V DC
Input Impedance	10 kΩ	10 kΩ
Max. Gain	0.8 A / 5 V	1 A / 5 V
Dither	Fix	Fix
Temperature Drift (Max.)	0.2 mA /°C	0.2 mA /°C
Power Supply	100 V AC, 200/220 V AC ± 10% (50/60 Hz)	
Power Input (Max.)	130 VA	
Ambient Temperature	0-50°C (32-122°F)	
External Setting Resistance	1 kΩ	1 kΩ
Approx. Mass	5.6 kg (12.3 lbs.)	

### ■ Instructions

Power supply for the setting adjuster up to two set can be provided from this power amplifier. However, please use the variable resistor or potentiometre of which impedance is 1 kΩ for the setting adjuster.

AME-D2-H1-\*-12

[Example Diagram]

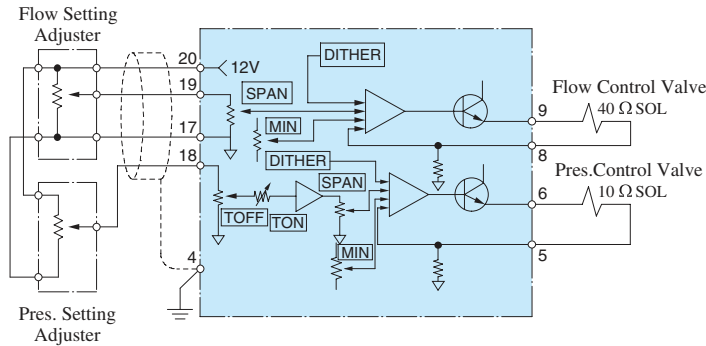

● Detail of Terminal Board

Terminal Number	Name
1	Power Supply 100 V AC, 200 V AC: 1, 2 220 V AC: 1, 3
2	
3	
4	Ground G
5	Output to Pressure Control
6	Valve (10 Ω) Solenoid PR. SOL
7	Ammeter
8	Output to Flow Control
9	Valve (40 Ω) Solenoid FL. SOL
10	Ammeter
11	Common COM
12	—
13	—
14	-12 V OUT -12 V
15	Common COM
16	+12 V OUT +12 V
17	Common COM
18	Input Signal for PRES. PR.IN
19	Input Signal for FLOW FL.IN
20	+12 V OUT +12 V

Terminal Board  
(Refer to the table on the right above.)

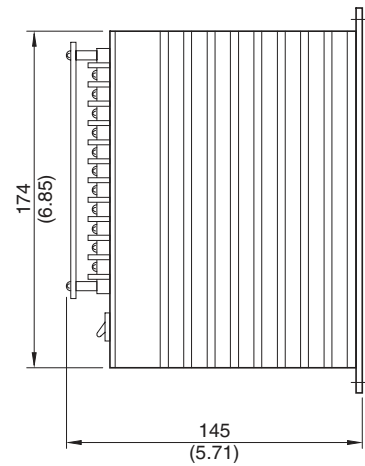
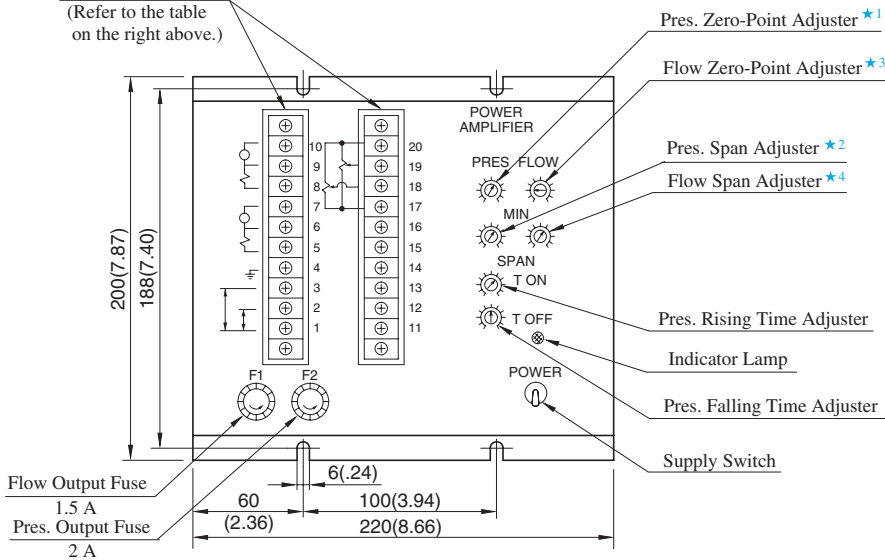

- ★ 1. Minimum Pressure Setting
- ★ 2. Variable Pressure Range Setting
- ★ 3. Minimum Flow Setting
- ★ 4. Variable Flow Range Setting

DIMENSIONS IN MILLIMETRES (INCHES)