



# PISTON PUMPS

Yuken offers low noise/high efficiency, swash plate type variable displacement piston pumps. These pumps have been developed by Yuken's leading hydraulic engineers and provide a diverse lineup to meet a wide range of application requirements.

## **ABR** Series Variable Displacement Piston Pumps ..... P15

- Compact and Lightweight  
A compact design and an aluminum body ensures a high power to mass ratio.
- Low Noise

## **A** Series Variable Displacement Piston Pumps ..... P27

- A variety of control methods are supported  
Ten types of unique control methods are available which integrate amplifiers and sensors. These control types range from standard pressure compensator control to proportional solenoid pressure/flow control.
- Available in a wide range of displacements from 10 to 219 cm<sup>3</sup>/rev (.610 to 13.36 cu. in./rev)

## **ABH** Series Variable Displacement Piston Pumps ..... P117

- Variable displacement piston pumps offer high pressure, high performance in a simple and compact package.
- High Pressure: 35 MPa (5080 PSI)
  - High volumetric efficiency  
These pumps maintain a high volumetric efficiency, even at a pressure of 35 MPa (5080 PSI).
  - Available in a wide range of displacements  
Seven models are available in displacements ranging of 16.3 to 180.7 cm<sup>3</sup>/rev (.995 to 11.03 cu. in./rev).



**"AR" Series Variable Displacement Piston Pumps**



**"A" Series Variable Displacement Piston Pumps**



**"A3H" Series Variable Displacement Piston Pumps**

# "AR" Series Variable Displacement Piston Pumps

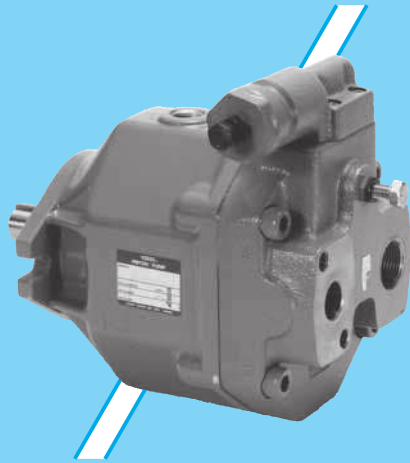

AR16  
Axial Port Type

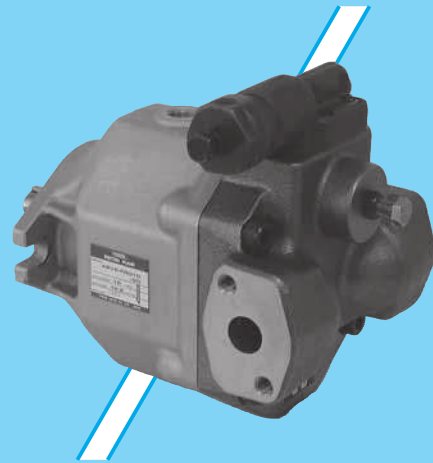

AR16  
Side Port Type

"AR" series variable displacement pump has been developed which the aim of even further the quietness in operation, smaller in size and lighter in mass and based on Yuken technology and engineering which put on market the "A" series pump which has a reputation for its quiet operation and high efficiency.

Pump Type	Graphic Symbol	Geometric Displacement										Maximum Operating Pressure MPa (PSI)	Page		
		1	2	5	10	20	50	100	200	300	cu. in./rev 10 15			cm <sup>3</sup> /rev	
"AR" Series Variable Displacement Piston Pumps					AR16									16 (2320)	18
					AR22										

**Hydraulic Fluids**

■ **Hydraulic Fluids**

Use petroleum base oils such as anti-wear type hydraulic oils or R & O (Rust and Oxidation inhibitor) type hydraulic oils equivalent to ISO VG-32 or 46. The recommended viscosity range is from 20 to 400 mm<sup>2</sup>/s (98 to 1800 SSU) and temperature range is from 0 to 60 °C (32 to 140 °F), both of which have to be satisfied for the use of the above hydraulic oils.

■ **Control of Contamination**

Due caution must be paid to maintaining control over contamination of the operating oil which can otherwise lead to breakdowns and shorten the life of the unit.

Please maintain the degree of contamination within NAS Grade 10.

The suction port must be equipped with at least a 100 μm (150 mesh) reservoir type filter and the return line must have a line type filter of under 10 μm.

**Instructions**

■ **Mounting**

When installing the pump the filling port should be positioned upwards.

■ **Alignment of Shaft**

Employ a flexible coupling whenever possible, and avoid any stress from bending or thrust.

Maximum permissible misalignment is less than 0.1 mm (.004 inches) TIR and maximum permissible misangular is less than 0.2°.

■ **Suction Pressure**

Permissible suction pressure at inlet port of the pump is between -16.7 and +50 kPa (5 in.Hg Vacuum and 7 PSIG). For piping to the suction port, use the pipes of the same diameter as that of the specified pipe flange to be used.

Make sure that the height of the pump suction port is within one metre (3.3 ft) from the oil level in the reservoir.

■ **Hints on Piping**

When using steel pipes for the suction or discharge ports, excessive load from the piping to the pump generates excessive noise.

Whenever there is fear of excessive load, please use rubber hoses.

■ **Suction Piping**

In case the pump is installed above the oil level, the suction piping and suction line filter should be located lower than the pump position to prevent air in the suction line.

■ **Drain Piping**

Install drain piping according to the chart and ensure that pressure within the pump housing should be maintained at a normal pressure of less than 0.1 MPa (14.5 PSI) and surge pressure of less than 0.5 MPa (72.5 PSI).

Length of piping should be less than 1 m (3.3 ft.), and the pipe end should be submerged in oil.

In case AR16 and AR22 pump, a screw-in torque of fitting is 40 to 50 Nm (354 to 443 IN.lbs.). Do not apply bending and thrust torque to the fitting.

[Recommended Drain Piping Size]

Model	Fitting Size		Inside Dia. of Pipe
	Japnese Std. "JIS" & European Design Std.	N.American Design Std.	
AR16, AR22	3/8 [Inside Dia. 8.5 mm (.33 in.) or more]	SAE #8	10 mm (.39 in.)

■ **Bleeding Air**

It may be necessary to bleed air from pump case and outlet line to remove causes of vibration. An air bleed valve (Model Number ST1004-\*-10\*, Page 820) is recommended for this purpose.



**Starting**

Before first starting, fill pump case with clean operating oil via the filling port.

In order to avoid air blockage when first starting, adjust the control valves so that the discharged oil from the pump is returned direct to the reservoir or the actuator moves in a free load.

[Volume of Pre-fill Oil Required]

Model	Volume cm <sup>3</sup> (in. <sup>3</sup> )
AR16 AR22	430 (26.2)

**Setting Discharge Pressure and Delivery**

At the time of shipment, the unit has been preset to maximum delivery and minimum discharge pressure.

Adjust the preset delivery and pressure to meet your system requirements.

**Adjustment of Discharge Pressure**

Turning the adjustment screw clockwise, increases pressure.

[ Volume adjusted by each full turn of the pressure adjustment screw ]

Model Numbers	Adjustment Volume MPa (PSI)
AR16/AR22-FR01B	2.9 (420)
AR16/AR22-FR01C	5.4 (780)

**Adjustment of Delivery**

Turning the delivery adjustment screw clockwise, decreases delivery.

[ The minimum adjustable flow and adjustable volume of each full turn of the delivery adjustment screw ]

Model Numbers	Adjustable volume with each full turn of the adjustment screw cm <sup>3</sup> /rev (cu.in./rev)	Minimum adjustable flow cm <sup>3</sup> /rev (cu.in./rev)
AR16	1.5 (.092)	6 (.366)
AR22	2.1 (.128)	8.5 (.519)

## "AR" Series Variable Displacement Piston Pumps

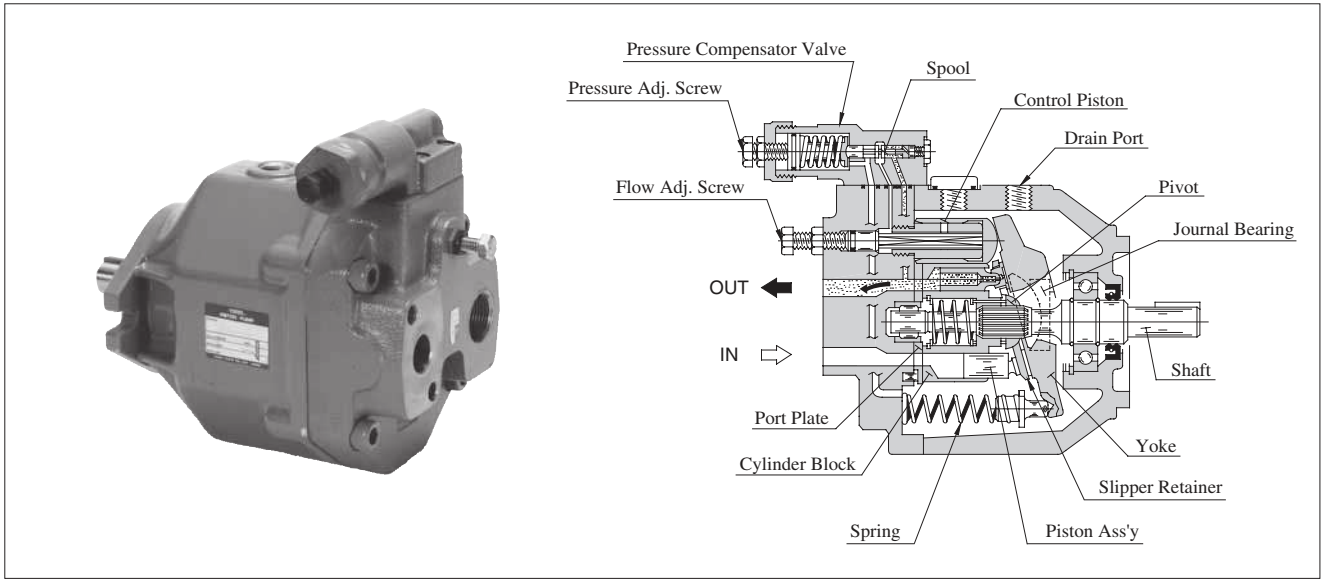

**■ Features**

**● Smaller in Size and Lighter in Mass**

As indicated in the dimensional comparison presented below, the AR16 is smaller than the A16 (32 design). Also, the mass of AR16 is substantially lighter than the A16.

**● Low Noise**

The noise level of AR16 has been reduced by 1-2 dB (A) at full flow and full cut-off compared with that of the excellent A16 quiet pump.

[Comparison of "AR16" with "A16"]

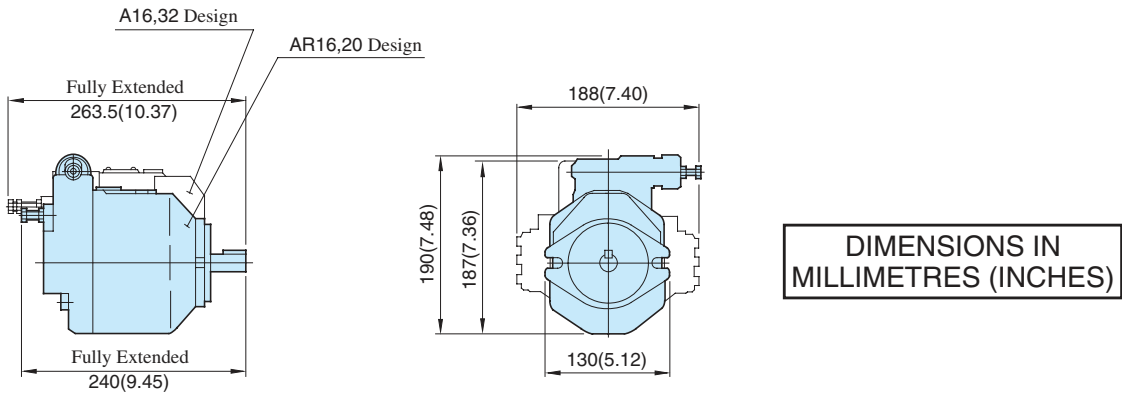

Model	Approx. Mass (Flange Mtg.)	Ratio of Mass (AR16/A16)
AR16	9.8 kg (21.6 lbs.)	60 %
A16	16.5 kg (36.4 lbs.)	



## "AR" Series Variable Displacement Piston Pumps – Single Pump, Pressure Compensator Type



Graphic Symbol

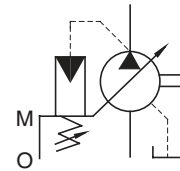

### Specifications

Model Numbers	Geometric Displacement cm <sup>3</sup> /rev (cu.in./rev)	Operating Pressure MPa (PSI)		Shaft Speed Range r/min.		Approx. Mass kg (lbs.)
		Rated	Intermittent*	Max.	Min.	
AR16-FR01*-20/2080/20950	15.8 ( .964)	16 (2320)		1800	600	9.8 (21.6)
AR22-FR01*-20/2080/20950	22.2 (1.355)			1800	600	

\* When setting the pressure, make sure the full cut-off pressure never exceeds the maximum intermittent pressure.

### Model Number Designation

AR16	-F	R	01	B	S	-20	*
Series Number	Mounting	Direction of Rotation	Control Type	Pres. Adj. Range MPa (PSI)	Port Position	Design Number	Design Std.
<b>AR16</b> (15.8 cm <sup>3</sup> /rev)	<b>F:</b> Flange Mtg.	(Viewed from Shaft End) <b>R:</b> ★1 Clockwise (Normal)	<b>01:</b> Pressure Compensator Type	<b>B:</b> 1.2 - 7 {170 - 1020} <b>C:</b> 2.0 - 16 {290 - 2320}	<b>None:</b> Axial Port <b>S:</b> Side Port	<b>20</b>	Refer to ★2
<b>AR22</b> (22.2 cm <sup>3</sup> /rev)						<b>20</b>	

★1. Available to supply pump with anti-clockwise rotation. Consult Yuken for details.

★2. Design Standards:  
None..... Japanese Standard "JIS"  
80..... European Design Standard  
950..... N. American Design Standard

### Pipe Flange Kits

Pipe flange kits are available.  
When ordering, specify the kit number from the table below.

Pump Model Numbers	Name of Port	Pipe Flange Kit Numbers				
		Threaded Connection			Socket Welding	
		Japanese Standard "JIS"	European Design Standard	N. American Design Standard	Japanese Standard "JIS" European Design Standard	N. American Design Standard
AR16-FR01 AR22-FR01	Suction	F5-06-A-1021	F5-06-A-10801	F5-06-A-10950	F5-06-B-1021	F5-06-B-10901
	Discharge *	_____	_____	_____	_____	_____

★ Discharge port is available only for the threaded connections.

• Detail of the pipe flange kits are shown on page 24.

### Mounting Bracket Kits

Mounting bracket available on separate order.  
Refer to page 24 for dimensions of the Mtg. bracket.

Pump Model Numbers	Mtg. Bracket Kit Numbers	Approx. Mass kg (lbs.)
AR16/AR22-FR01	LP-1A-10	2.2 (4.9)

Note: The mounting bracket kit consists of a mounting bracket, two hex. bolts and two plain washers.

Typical Pump Characteristics of Type "AR16" at Viscosity 20 mm<sup>2</sup>/s (100 SSU) [ISO VG32 Oils, 50°C (122°F)]

**Performance Characteristic Curve**

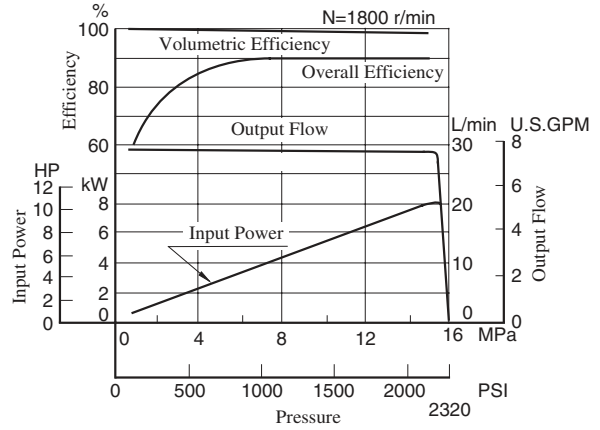
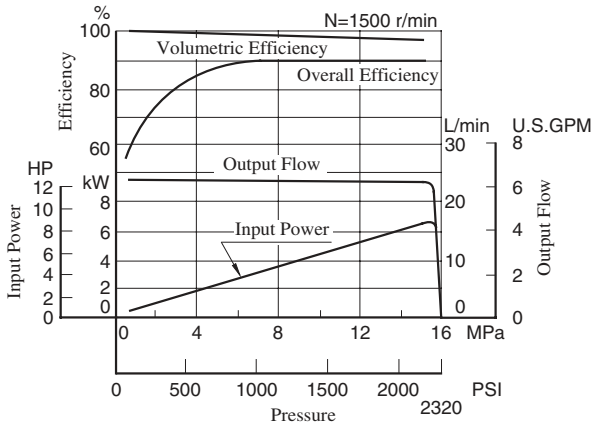

**Input Power**

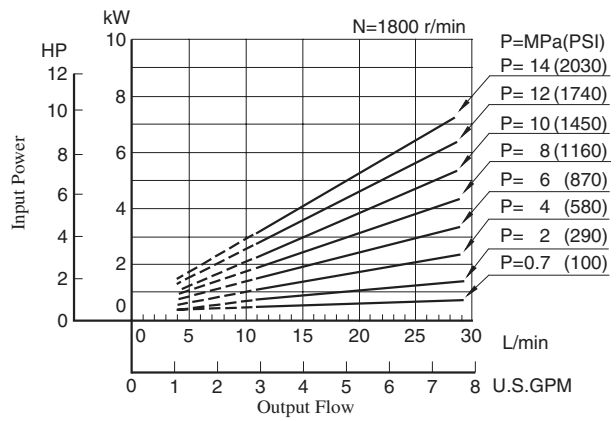
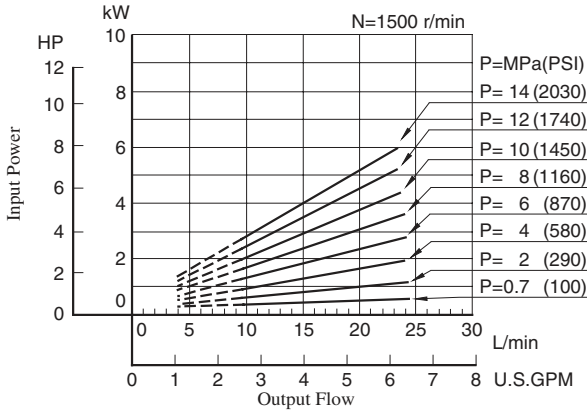

**Full Cut-off Power**

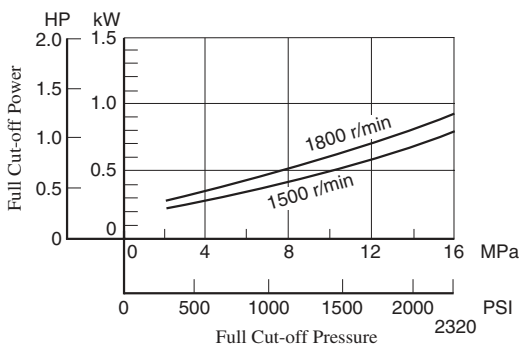

**Drain**

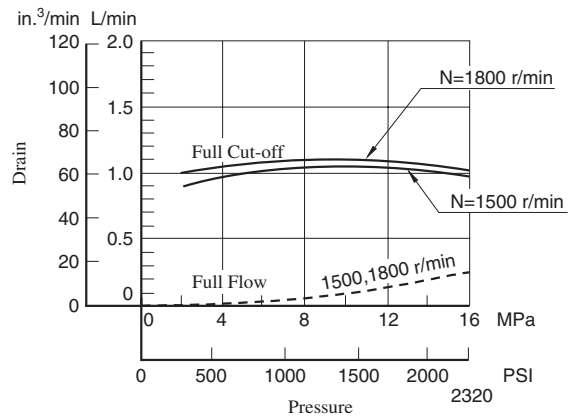

**Noise Level** [One metre (3.3 ft.) horizontally away from pump head cover]

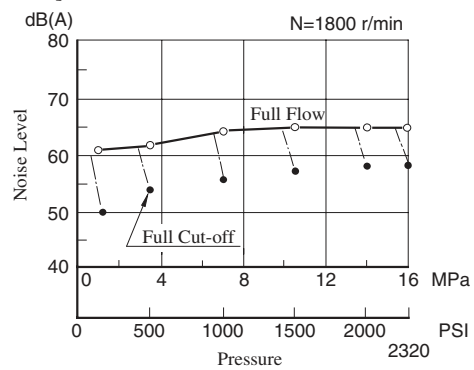
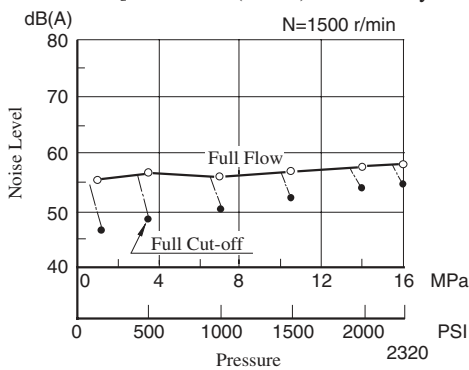





Typical Pump Characteristics of Type "AR22" at Viscosity 20 mm<sup>2</sup>/s (100 SSU) [ISO VG32 Oils, 50°C (122°F)]

### Performance Characteristic Curve

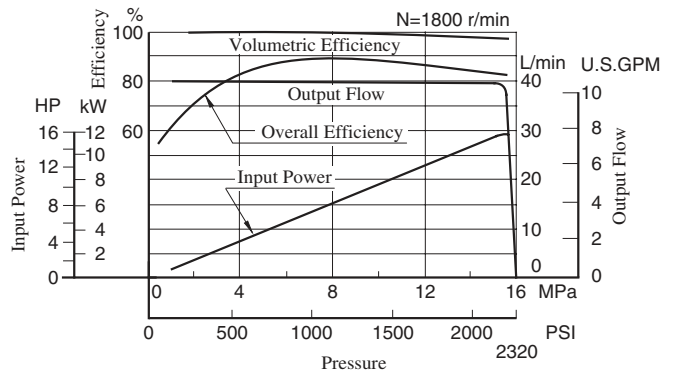
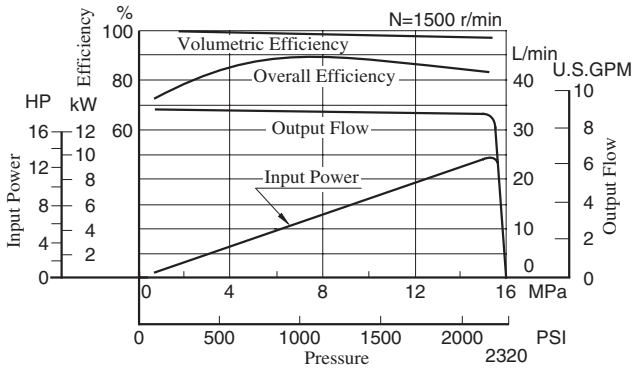

### Input Power

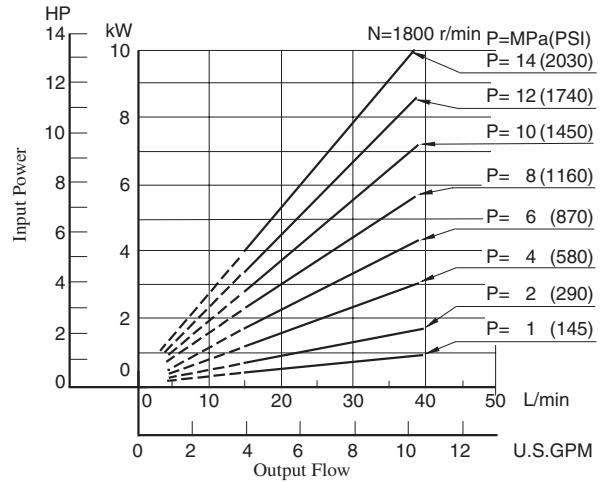
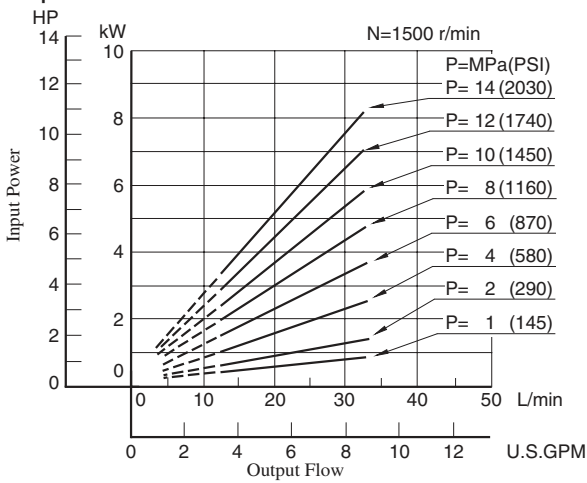

### Full Cut-off Power

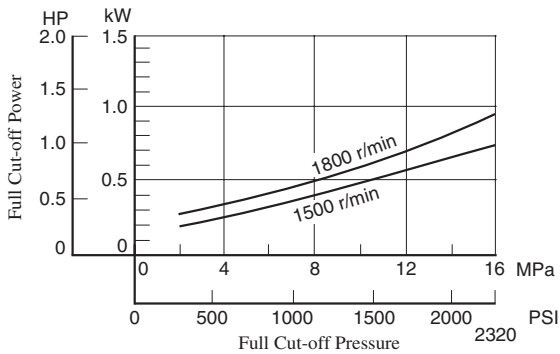

### Drain

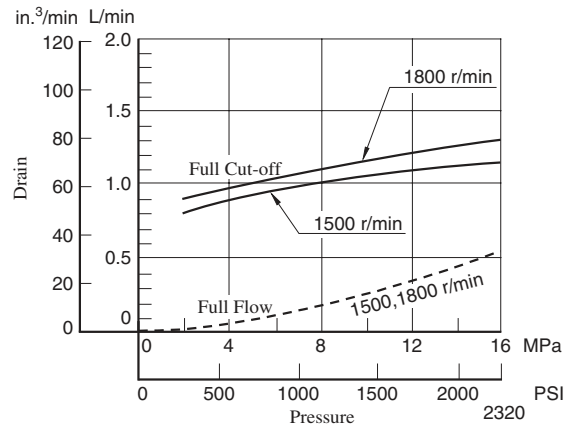

### Noise Level [One metre (3.3 ft.) horizontally away from pump head cover]

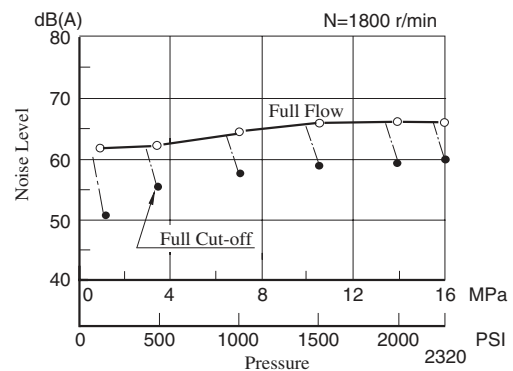
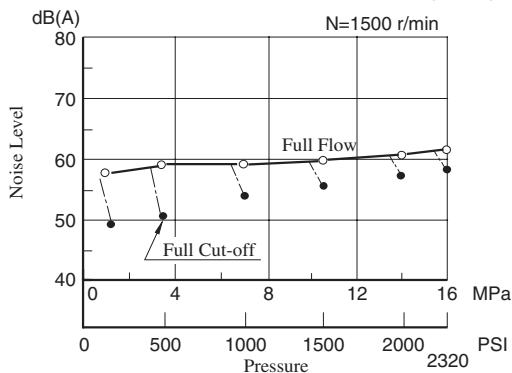

**Response Characteristics Change in Accordance with Circuits and Operating Conditions.**

■ Test Circuit and Conditions

● **Circuit**

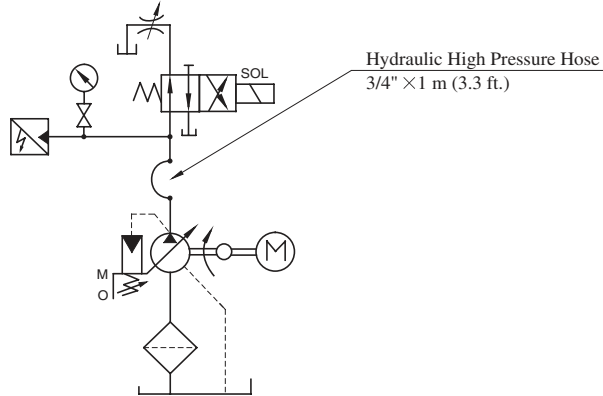

● **Conditions**

- Drive Speed : 1500 r/min
- Hydraulic Fluid : ISO VG32 oil
- Oil Temperature : 50 °C (122 °F)
- Viscosity : 20 mm<sup>2</sup>/s (100 SSU)

■ Result of Measurement

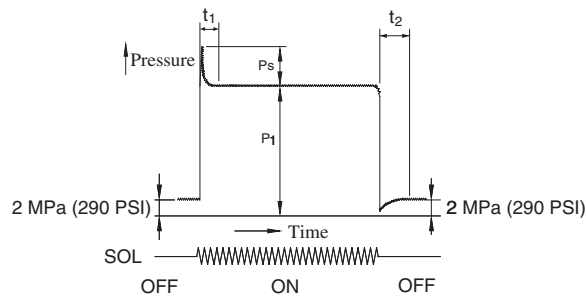

Model	Full Cut-off Pressure P <sub>1</sub> MPa (PSI)	Response Time ms		Overshoot Pressure P <sub>s</sub> MPa (PSI)
		t <sub>1</sub>	t <sub>2</sub>	
AR16	16 (2320)	60	65	5.6 ( 810)
AR22		70	70	7.3 (1060)

AR16-FR01\*-20/2080/20950  
AR22-FR01\*-20/2080/20950

**Axial Port Type**

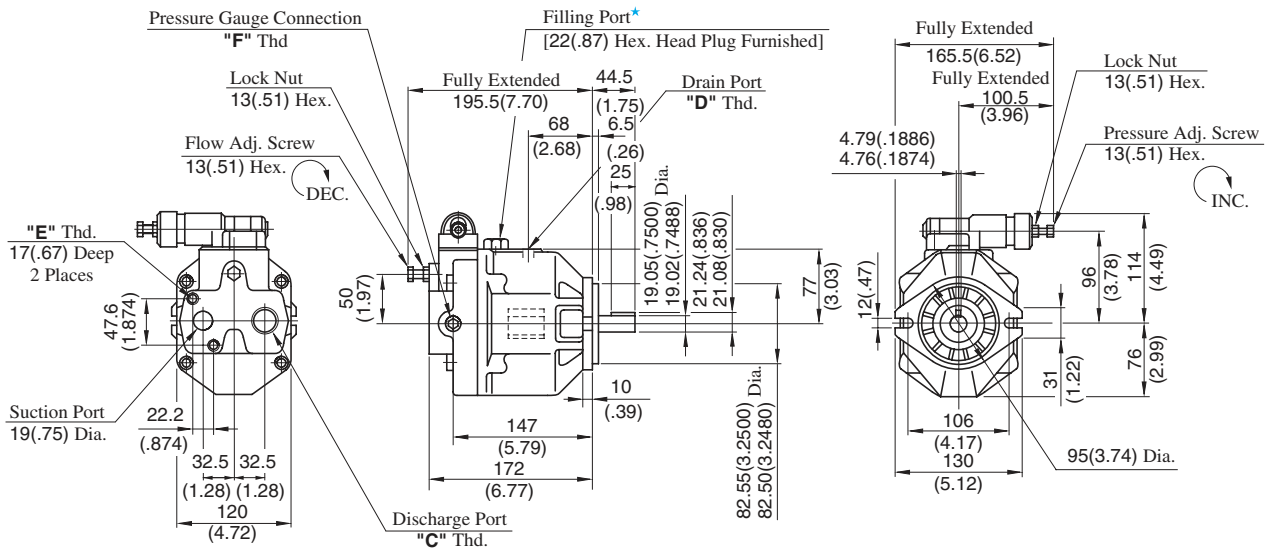

\* Install the pump so that the "Filling port" is at the top.

Model Numbers	"C" Thd.	"D" Thd.	"E" Thd.	"F" Thd.
AR16/AR22-FR01*-20	Rc 3/4	Rc 3/8	M10	Rc 1/4
AR16/AR22-FR01*-2080	3/4 BSP.F	3/8 BSP.F		1/4 BSP.Tr
AR16/AR22-FR01*-20950	SAE #12	SAE #8	3/8-16 UNC	SAE #4

DIMENSIONS IN MILLIMETRES (INCHES)

AR16-FR01\*S-20/2080/20950  
AR22-FR01\*S-20/2080/20950

**Side Port Type**

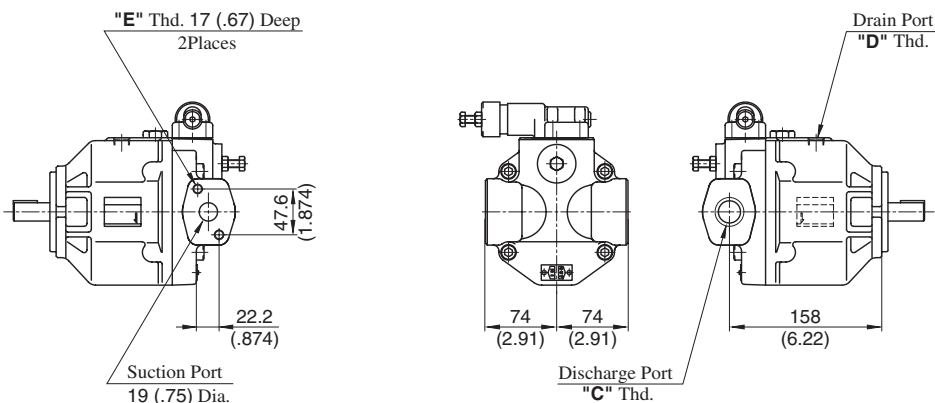

Model Numbers	"C" Thd.	"D" Thd.	"E" Thd.
AR16/AR22-FR01*S-20	Rc 3/4	Rc 3/8	M10
AR16/AR22-FR01*S-2080	3/4 BSP.F	3/8 BSP.F	
AR16/AR22-FR01*S-20950	SAE #12	SAE #8	3/8-16 UNC

• For other dimensions, refer to "Axial Port Type".

**Pipe Flange Kit for Suction Port**

- Threaded Connection

**Japanese Std. "JIS": F5-06-A-1021**

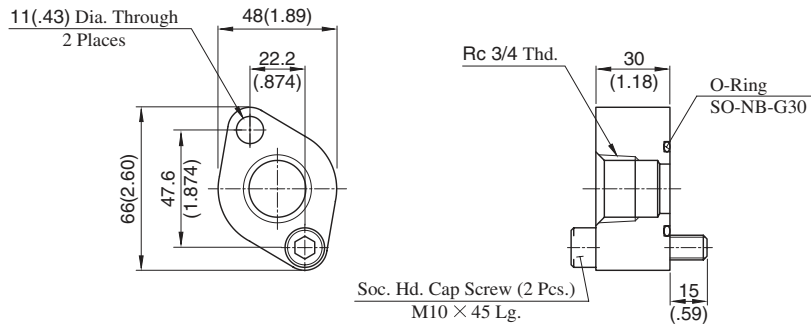

Approx. Mass ..... 0.5 kg (1.1 lbs.)

**European Design Std.: F5-06-A-10801**

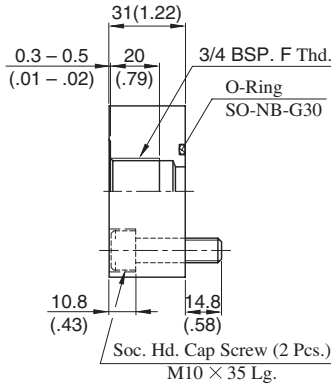
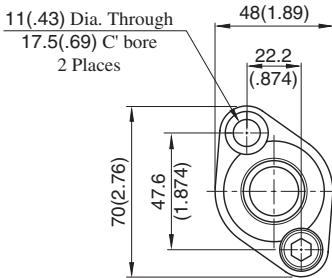

Approx. Mass ..... 0.5 kg (1.1 lbs.)

**N. American Design Std.: F5-06-A-10950**

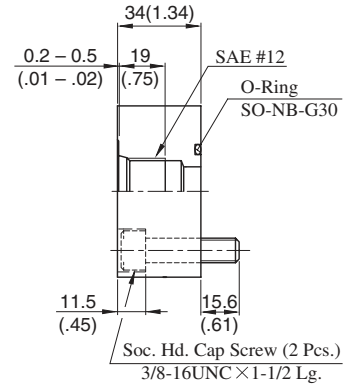

- Socket Welding

**F5-06-B-1021/10901**

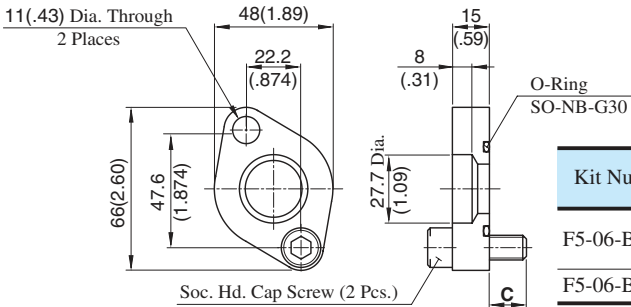

Approx. Mass ..... 0.3 kg (.66 lbs.)

Kit Numbers	C mm (In.)	Soc. Hd. Cap Screw	Remarks
F5-06-B-1021	15 (.59)	M10 x 45Lg.	Japanese Std. "JIS" European Design Std.
F5-06-B-10901	16.75 (.66)	3/8-16 UNC x 1-1/4 Lg.	N. American Design Std.

**DIMENSIONS IN  
MILLIMETRES (INCHES)**

**Mtg. Bracket Kit: LP-1A-10**

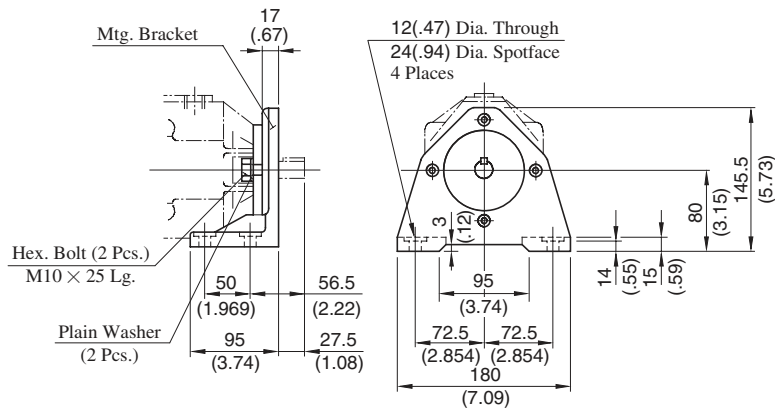

### Spare Parts List

AR16-FR01\*-20/2080/20950  
AR22-FR01\*-20/2080/20950

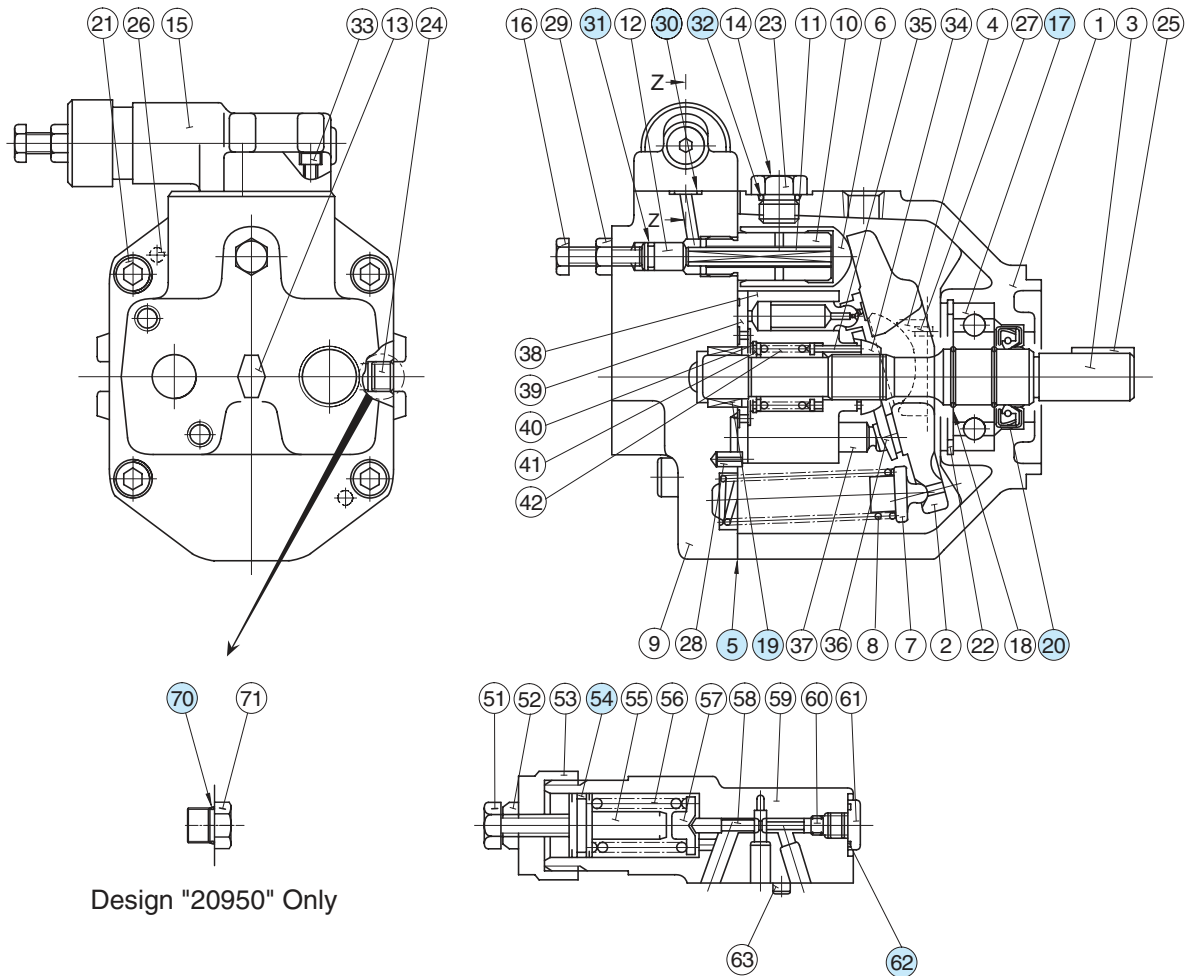

Section Z-Z

#### List of Seals & Bearings

Item	Name of Parts	Part Numbers		Qty.
		AR16-FR01	AR22-FR01	
5*	Gasket	1302-PK312891-5		1
17	Bearing	6305		1
19	Bearing	HMK 1715 V2	Z30-1303-PK410300-8	1
20*	Oil Seal	TCN 254511		1
30*	O-Ring	SO-NB-P9		3
31*	O-Ring	SO-NA-P8		1
32*	O-Ring	SO-NB-P14		1
54*	O-Ring	SO-NA-A018		1
62*	O-Ring	SO-NB-P10		1
70	O-Ring	SO-NB-A905		1

\*When ordering seals, please specify the seal kit number from the table below.

#### List of Seal Kits

Pump Model Numbers	Seal Kit Number
AR16-FR01*-20/2080/20950	KS-AR16-01-20
AR22-FR01*-20/2080/20950	

## Interchangeability in Installation between "A" Series and "AR" Series

### Specifications

Model		A16-*-R-01-*-K-32*	AR16-FR01*-20*	A22-*-R-01-*-K-32*	AR22-FR01*-20*
Description		A16-*-R-01-*-K-32*	AR16-FR01*-20*	A22-*-R-01-*-K-32*	AR22-FR01*-20*
Geometric Displacement		15.8 cm <sup>3</sup> /rev (.964 cu.in./rev)		22.2 cm <sup>3</sup> /rev (1.355 cu.in./rev)	
Operating Pres.	Rated	16 MPa (2320 PSI)		16 MPa (2320 PSI)	
	Intermittent	21 MPa (3050 PSI)	16 MPa (2320 PSI)	16 MPa (2320 PSI)	
Shaft Speed Range		600 -1800 r/min		600 -1800 r/min	
Approx. Mass (Flange Mtg.)		16.5 kg (36.4 lbs.)	9.8 kg (21.6 lbs.)	16.5 kg (36.4 lbs.)	9.8 kg (21.6 lbs.)

### Interchangeability in Installation

Model Numbers		Interchangeability in Installation			
"A" Series	"AR" Series	Mtg. Flange & Shaft End	Piping		
			Suction Port	Discharge Port	Drain Port
A16-*-R-01-*-K-32*	AR16-FR01*-20*	Yes	Yes	No	No
A22-*-R-01-*-K-32*	AR22-FR01*-20*				

• Comparison of dimensions between "A" series and "AR" series are shown below.

### A16/A22-F-R-01-\*-K

Note: Dimensions with star mark ★ are identical to each other.

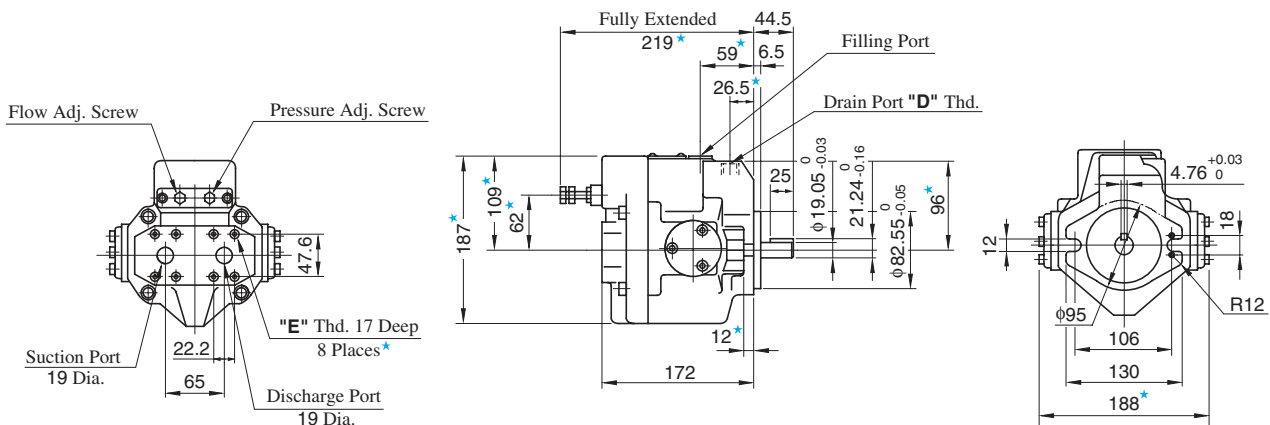

Model Numbers	"C" Thd.	"D" Thd.	"E" Thd.	"F" Thd.
A16/A22-F-R-01-*-K-32	—	Rc 3/8	M10	—
A16/A22-F-R-01-*-K-3280	—	3/8 BSP.F		—
A16/A22-F-R-01-*-K-32950	—	SAE #8		3/8-16 UNC
AR16/22-FR01*-20	Rc 3/4	Rc 3/8	M10	Rc 1/4
AR16/22-FR01*-2080	3/4 BSP.F	3/8 BSP.F		1/4 BSP.Tr
AR16/22-FR01*-20950	SAE #12	SAE #8	3/8-16 UNC	SAE #4

### AR16/AR22-FR01

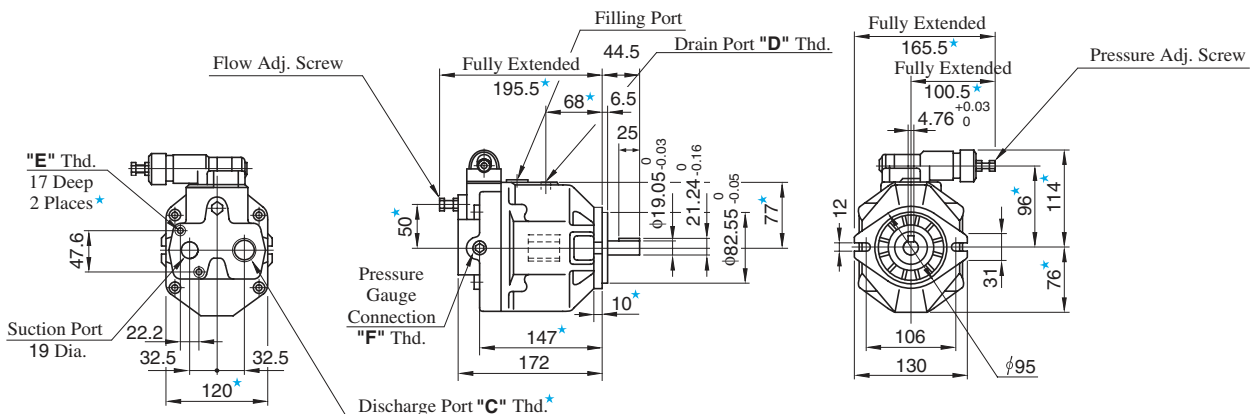

# "A" Series Variable Displacement Piston Pumps

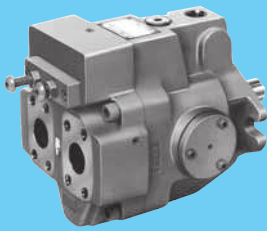

A37

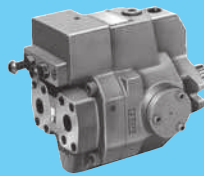

A16

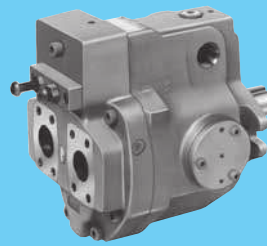

A56

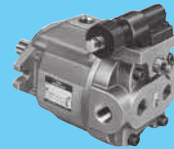

A10

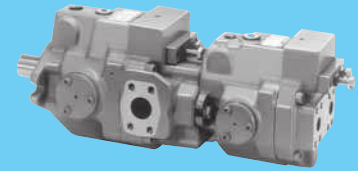

A1637

## "A" Series Variable Displacement Piston Pumps

Pump Type	Graphic Symbols	Geometric Displacement		Maximum Operating Pressure MPa (PSI)	Page
		cm <sup>3</sup> /rev	cu. in./rev		
Single Pumps				21 (3050)	30
				16 (2320)	
				21 (3050)	
				28 (4060)	
				16 (2320)	
		Double Pumps		Outboard Pump	
Inboard Pump	A16 A37 A56 A70 A90 A145 A220				
Variable / Fixed Double Pumps		Outboard Pump	PV2R1 PV2R2	28 (4060)*	115
		Inboard Pump	A16 A37 A56 A70 A90 A145 A220		

• Various control types are available such as pressure compensator type. Refer to page 31 and 32.

★ The maximum operating pressure for each double pump depends on its combination of pumps. Contact us for details.

## Hydraulic Fluids

### Hydraulic Fluids

Use petroleum based oils such as anti-wear type hydraulic oils or R & O (Rust and Oxidation inhibitor) type hydraulic oils equivalent to ISO VG-32 or 46. The recommended viscosity range is from 20 to 400 mm<sup>2</sup>/s (98 to 1800 SSU) and temperature range is from 0 to 60°C (32 to 140°F), both of which have to be satisfied for the use of the above hydraulic oils.

### Control of Contamination

Due caution must be paid to maintaining control over contamination of the operating oil which can otherwise lead to breakdowns and shorten the life of the unit.

Please maintain the degree of contamination within NAS Grade 10.

The suction port must be equipped with at least a 100 μm (150 mesh) reservoir type filter and the return line must have a line type filter of under 10 μm.

## Instructions

### Mounting

When installing the pump the filling port should be positioned upwards.

### Alignment of Shaft

Employ a flexible coupling whenever possible, and avoid any stress from bending or thrust.

Maximum permissible misalignment is less than 0.1 mm (.004 inches) TIR and maximum permissible misangular is less than 0.2°.

### Suction Pressure

Permissible suction pressure at inlet port of the pump is between -16.7 and +50 kPa (5 in.Hg Vacuum and 7 PSIG).

For piping to the suction port, use the pipes of the same diameter as that of the specified pipe flange to be used. Make sure that the height of the pump suction port is within one metre (3.3 ft) from the oil level in the reservoir.

### Hints on Piping

When using steel pipes for the suction or discharge ports, excessive load from the piping to the pump generates excessive noise.

Whenever there is fear of excessive load, please use rubber hoses.

### Suction Piping

In case the pump is installed above the oil level, the suction piping and suction line filter should be located lower than the pump position to prevent air in the suction line.

When using steel pipes for the suction or discharge ports, excessive load from the piping to the pump generates excessive noise.

Whenever there is fear of excessive load, please use rubber hoses.

### Drain Piping

Install drain piping according to the chart and ensure that pressure within the pump housing should be maintained at a normal pressure of less than 0.1 MPa (14.5 PSI) and surge pressure of less than 0.5 MPa (72.5 PSI).

Length of piping should be less than 1 m (3.3 ft.), and the pipe end should be submerged in oil.

[Recommended Drain Piping Size]

Model	Fitting Size		Inside Dia. of Pipe
	Japnese Std. "JIS" & European Design Std.	N.American Design Std.	
A10	3/8 [Inside Dia. 8.5 mm (.33 in.) or more]	SAE #6	10 mm (.39 in.)
A16, A22	3/8 [Inside Dia. 8.5 mm (.33 in.) or more]	SAE #8	
A37	1/2 [Inside Dia. 10 mm (.47 in.) or more]	SAE #10	12 mm (.47 in.)
A56, A70 A90, A145	3/4 [Inside Dia. 16 mm (.63 in.) or more]	SAE #12	19 mm (.75 in.)

### Bleeding Air

It may be necessary to bleed air from pump case and outlet line to remove causes of vibration. An air bleed valve (Model Number ST1004-\*-10\*, Page 820) is recommended for this purpose.





**Starting**

Before first starting, fill pump case with clean operating oil via the filling port.

In order to avoid air blockage when first starting, adjust the control valves so that the discharged oil from the pump is returned direct to the reservoir or the actuator moves in a free load.

[Volume of Pre-fill Oil Required]

Model	Volume cm <sup>3</sup> (cu.in.)
A10	370 (22.6)
A16/A22	600 (36.6)
A37/A56	1200 (73.2)
A70	2100 (128)
A90	2500 (153)
A145	3300 (201)

**Setting Discharge Pressure and Delivery**

At the time of shipment, the unit has been preset to maximum delivery and minimum discharge pressure.

Adjust the preset delivery and pressure to meet your system requirements.

**Adjustment of Discharge Pressure**

Turning the adjustment screw clockwise, increases pressure.

[ Volume adjusted by each full turn of the pressure adjustment screw ]

Model Numbers	Adjustment Volume MPa (PSI)
A10-FR01B	2.9 (420)
A10-FR01C/H	5.4 (780)
A16/A22/A37/A56-*-R-01-B	3.5 (510)
A16/A22/A37/A56-*-R-01-C	6.5 (940)
A16/A37/A56-*-R-01-H	7.9 (1150)
A70/A90/A145-*-R01B	2.3 (330)
A70/A90/A145-*-R01C	3.2 (460)
A70/A90/A145-*-R01H	4.0 (580)
A70/A90/A145-*-R01K	4.7 (680)

**Adjustment of Delivery**

Turning the flow adjustment screw clockwise, decreases delivery.

[ The minimum adjustable flow and adjustable volume of each full turn of the delivery adjustment screw ]

Model Numbers	Adjustable volume with each full turn of the adjustment screw cm <sup>3</sup> /rev (cu.in./rev)	Minimum adjustment flow cm <sup>3</sup> /rev (cu.in./rev)
A10	1.1 (.067)	2.0 (.122)
A16	1.4 (.085)	4.0 (.244)
A22	2.0 (.122)	6.0 (.366)
A37	2.9 (.177)	10 (.610)
A56	3.9 (.238)	12 (.732)
A70	4.4 (.268)	30 (1.83)
A90	4.8 (.293)	56 (3.42)
A145	7.2 (.439)	83 (5.06)

## "A" Series Variable Displacement Piston Pumps

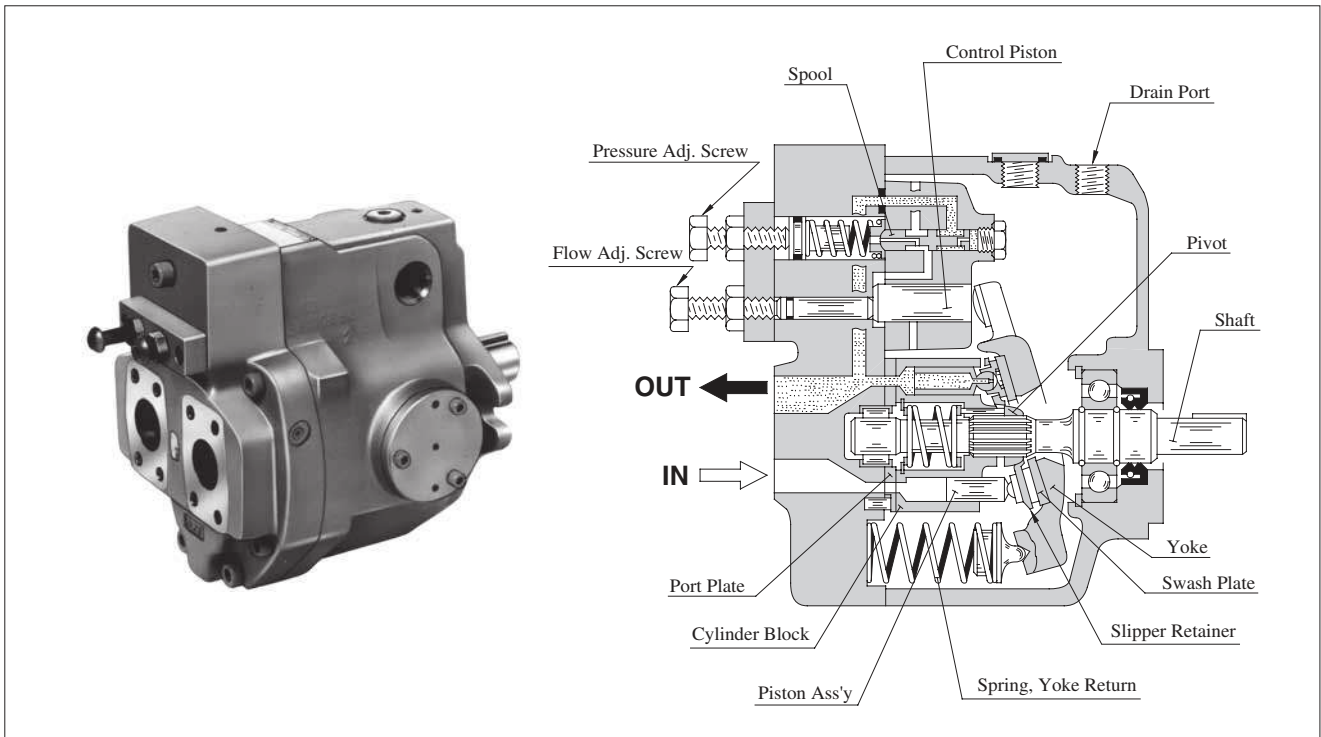

### ■ Features

#### ● High efficiency

Under the conditions of pressure 16 MPa (2320 PSI) and speed 1800 r/min, the volumetric efficiency is over 98% and the overall efficiency is over 90%.

#### ● Low noise level

In the "A16" pump, the noise level is as low as 57.3 dB(A) [at the full cut-off pressure 21 MPa (3050 PSI) with speed 1500 r/min one metre (3.3 ft.) horizontally away from pump head cover.]

"A16" type performance characteristics

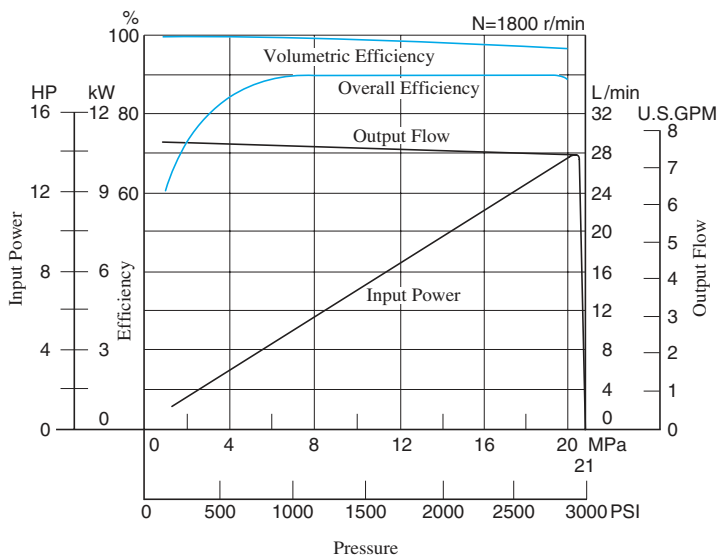

"A16" type noise level characteristics

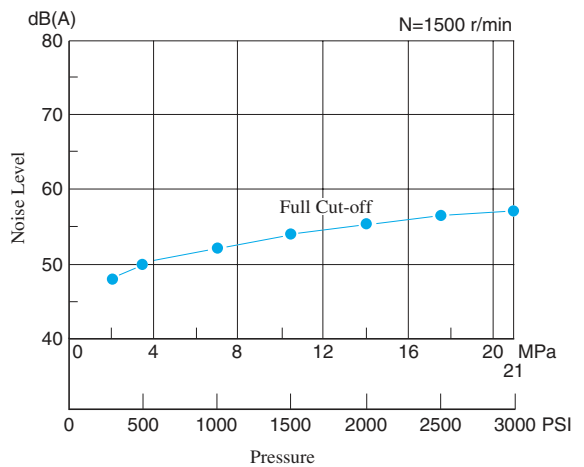

#### ● Accomplishment of energy-saving

Because the overall efficiency is high and the cut-off characteristics is sharp, thus the input power may be saved.

#### ● Low heat generation

Because of small power loss, it is possible to reduce the rise in oil temperature. Accordingly, capacity of a reservoir can be reduced.



Control Type

Control Type	Graphic Symbols	Performance Characteristics	Explanation	Page
"01" Pressure Compensator Type			When the system pressure increases and comes close to the preset cut-off pressure, the pump flow decreases automatically while maintaining the set pressure as it is.	33
"02" Solenoid-two Pressure Control Type			This type of control is ideal for an application where the output power of the actuator has to be controlled in two different load pressures while keeping the actuator speed nearly constant.	55
"03" Pressure Compensator with Unloading Type			It is suitable for a situation where a long unloading time is required and heat generation and noise have to be kept at their lowest levels. <ul style="list-style-type: none"> <li>The pump can be used in combination with the multistage pressure control valve.</li> </ul>	63
"04" Proportional Electro-Hydraulic Load Sensing Type			This is an energy-saving type control which regulates the pump flow and load pressure to be at absolute minimum necessary level to operate the actuator. Pump flow rate and cut-off pressure are controlled proportional to the input current to the control device on the pump and the input current is regulated by the specific amplifier.	64
"04E" Electro-Hydraulic Proportional Pressure & Flow Control Type			This type of control has the pressure sensor and tilt angle sensor in the pump. The pump is used with the external amplifier (amplifier is integrated into pump in case of "04EH").	74
"04EH" Electro-Hydraulic Proportional Pressure & Flow Control Type (OBE Type)			Flow and pressure can be controlled in proportion to input voltage by only one control valve. The features has been greatly improved by electrical feedback of swash plate tilt angle correspond to flow rate and load pressure to control valve. <ul style="list-style-type: none"> <li>Linearity of input characteristics is excellent and easy to set.</li> <li>Hysteresis is lower, repeatability and reproducibility are fine.</li> </ul>	86
"05" Two-Pressure Two-Flow Control Type by System Pres.			This type of control is suitable for an application like "Presses" where the changeover from rapid advance to feed is required just when the pressing (pressurizing) starts.	— *
"06" Two-Pressure Two-Flow Control Type by Solenoid Valve			This pump control is suitable for machining found on machine tool, where machining starts after the changeover from rapid advance, to feed has been made.	— *

**Control Type**

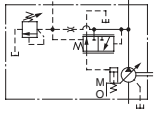
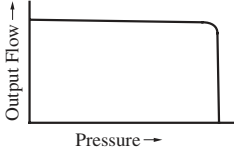
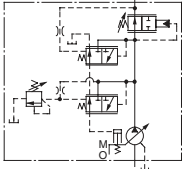
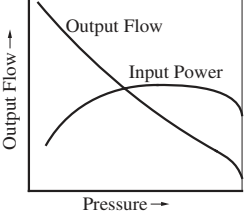
Control Type	Graphic Symbols	Performance Characteristics	Explanation	Page
"07" Pilot Pressure Control Type Pressure Compensator			The pump is used in combination with the pilot relief valve or multistage pressure control valve. By controlling the pilot pressure, the full cut-off pressure can be remote-controlled according to your requirements.	96
"09" Constant Power Control Type			<ul style="list-style-type: none"> <li>• Pump input power can be controlled in accordance with the motor output.</li> <li>• When the discharge pressure rise, the output flow decreases corresponding to the preset input power.</li> <li>• The pump can act for function of two pumps, low-pressure large-flow and high-pressure small-flow. Therefore, the motor capacity can be reduced.</li> </ul>	105

★ Control type "05" and "06" are not shown in this catalogue. Contact us for the details.

**Availability of Control Type**

Mark "○" in the table below refers to standard model.

Model Numbers	Geometric Displacement cm <sup>3</sup> /rev (cu.in./rev)	Control Type									
		01	02	03	04	04E	04EH	05	06	07	09
A10	10.0 (.610)	○								○	
A16	15.8 (.964)	○	○	○	○	○	○	○	○	○	○
A22	22.2 (1.355)	○	○	○	○	○	○		○	○	
A37	36.9 (2.25)	○	○	○	○	○	○	○	○	○	○
A56	56.2 (3.43)	○	○	○	○	○	○	○	○	○	○
A70	70.0 (4.27)	○	○	○	○	○	○		○	○	○
A90	91.0 (5.55)	○	○	○	○	○	○		○	○	
A145	145 (8.85)	○	○	○	○	○	○		○	○	○



# "A" Series Variable Displacement Piston Pumps – Single Pump, Pressure Compensator Type

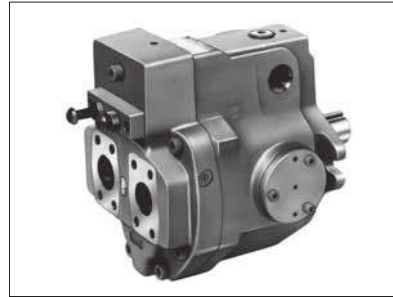

Graphic Symbol

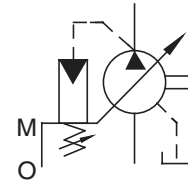

## Specifications

Model Numbers	Geometric Displacement cm <sup>3</sup> /rev (cu. in. /rev)	Minimum Adj. Flow cm <sup>3</sup> /rev (cu. in. /rev)	Operating Pressure MPa (PSI)		Shaft Speed Range r/min		Approx. Mass kg (lbs.)	
			Rated <sup>*2</sup>	Intermittent <sup>*1</sup>	Max.	Min.	Flange Mtg.	Foot Mtg.
A10-FR01B-12*	10.0 (.610)	2 (.122)	16 (2320)	21 (3050)	1800	600	5.1 (11.2)	—
A10-FR01C/H-12*							8.5 (18.7)	
A16-*R-01-*K-32*	15.8 (.964)	4 (.244)	16 (2320)	21 (3050)	1800	600	16.5 (36.4)	18.7 (41.2)
A22-*R-01-*K-32*	22.2 (1.355)	6 (.366)	16 (2320)	16 (2320)	1800	600	16.5 (36.4)	18.7 (41.2)
A37-*R-01-*K-32*	36.9 (2.25)	10 (.610)	16 (2320)	21 (3050)	1800	600	28.0 (61.7)	32.3 (71.2)
A56-*R-01-*K-32*	56.2 (3.43)	12 (.732)	16 (2320)	21 (3050)	1800	600	35.0 (77.2)	39.3 (86.7)
A70-*R01*S-60*	70.0 (4.27)	30 (1.83)	25 (3630)	28 (4060)	1800	600	58.5 (129)	70.5 (155)
A90-*R01*S-60*	91.0 (5.55)	56 (3.42)	25 (3630)	28 (4060)	1800	600	72.5 (160)	93 (205)
A145-*R01*S-60*	145 (8.85)	83 (5.06)	25 (3630)	28 (4060)	1800	600	92.5 (204)	117.5 (259)

- ★1. Whenever setting pressure, make sure the full cut-off pressure never exceeds the maximum intermittent pressure.
- ★2. Care should be taken in cases of used at a higher pressure than the rated pressure, because operating terms may be restricted. For example, if used as per maximum illustrated operating conditions, intermittent time at maximum flow is restricted to under 1/5 of one cycle time and under six seconds simultaneously. Conditions may vary according to the actual working pressure and delivery (inclination angle of the swash plate). Consult factory or Yuken sales representative for further information.
- ★3. The table above shows specifications for using petroleum based oils. Pumps (customized design) for special fluids are also available. Their operating pressure and maximum shaft speed however differ from the values in the table above depending on the fluid type. Range of operating temperature and viscosities may differ from those of petroleum based oils due to their characteristics.

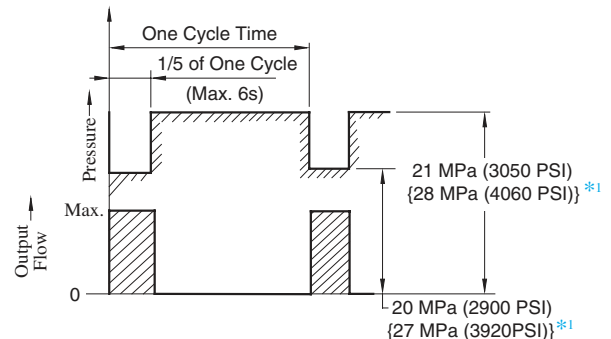

\*1. Applicable only for "A70/90/145"

## Specifications and Design numbers for Special Fluids

Type of Fluids	Pump Series	Operating Pressure MPa (PSI)		Allowable Maximum Shaft Speed r/min		Temperature Range °C (°F)	Viscosity Range mm <sup>2</sup> /s (SSU)	Design Numbers for Special Fluid (Occasion of Japanese Std. "JIS") <sup>*3</sup>
		Rated	Intermittent	Rated	Max.			
Water-Glycols	A16 – A56	14(2030)	16(2320) {14(2030)} <sup>*1</sup>	1200	(1800) <sup>*2</sup>	0 - 50 (32 - 104)	20 - 200(98 - 927)	3230
	A70 – A145	21(3050)	21(3050)					6030
Phosphate Ester Type	A16 – A56	14(2030)	16(2320) {14(2030)} <sup>*1</sup>	1200	(1800) <sup>*2</sup>	0 - 60 (32 - 140)	20 - 200(98 - 927)	3206
	A70 – A145	21(3050)	21(3050)					6006
Polyol Ester Type	A16 – A56	16(2320)	16(2320)	1800	1800	0 - 60 (32 - 140)	20 - 200(98 - 927)	32450
	A70 – A145	21(3050)	21(3050)					60450

- ★1. The figures in brackets are for A22 type.
- ★2. As the specific gravities of water-glycol fluids and phosphate ester type fluids are higher than one, an overhead reservoir is required when pumps are operated at 1500 r/min or more.
- ★3. For the design numbers of pumps for European Design and North American Design Standards, please contact us.

**Model Number Designation**

A16	-F	-R	-01	-B	-S	-K	-32	*
Series Number	Mounting	Direction of Rotation	Control Type	Pres. Adj. Range MPa (PSI)	Port Position	Shaft Extension	Design Number	Design Std.
<b>A16</b> (15.8 cm <sup>3</sup> /rev)	<b>F:</b> Flange Mtg.	(Viewed from Shaft End)	<b>01:</b> Pressure Compensator Type	<b>B:</b> 1.2 - 7 (170 - 1020) <b>C:</b> 1.2 - 16 (170 - 2320) <b>H:</b> 1.2 - 21 (170 - 3050)	<b>None:</b> Axial Port	<b>K:</b> Keyed Shaft	<b>32</b>	Refer to <sup>*2</sup>
<b>A22</b> (22.2 cm <sup>3</sup> /rev)				<b>B:</b> 1.2 - 7 (170 - 1020) <b>C:</b> 1.2 - 16 (170 - 2320)			<b>32</b>	
<b>A37</b> (36.9 cm <sup>3</sup> /rev)	<b>L:</b> Foot Mtg.	<b>R:</b> Clockwise (Normal) <sup>*1</sup>		<b>B:</b> 1.2 - 7 (170 - 1020) <b>C:</b> 1.2 - 16 (170 - 2320) <b>H:</b> 1.2 - 21 (170 - 3050)	<b>S:</b> Side Port		<b>32</b>	
<b>A56</b> (56.2 cm <sup>3</sup> /rev)							<b>32</b>	

A70	-F	R	01	B	S	-60	*
Series Number	Mounting	Direction of Rotation	Control Type	Pres. Adj. Range MPa (PSI)	Port Position	Design Number	Design Std.
<b>A10</b> (10.0 cm <sup>3</sup> /rev)	<b>F:</b> Flange Mtg. <sup>*3</sup>	(Viewed from Shaft End)	<b>01:</b> Pressure Compensator Type	<b>B:</b> 1.2 - 7 (170 - 1020) <sup>*4</sup> <b>C:</b> 2.0 - 16 (290 - 2320) <b>H:</b> 2.0 - 21 (290 - 3050)	—	<b>12</b>	Refer to <sup>*2</sup>
<b>A70</b> (70.0 cm <sup>3</sup> /rev)	<b>F:</b> Flange Mtg.			<b>B:</b> 1.2 - 7 (170 - 1020) <b>C:</b> 1.5 - 16 (220 - 2320) <b>H:</b> 1.8 - 21 (260 - 3050) <b>K:</b> 2.0 - 28 (290 - 4060)	<b>S:</b> Side Port	<b>60</b>	
<b>A90</b> (91.0 cm <sup>3</sup> /rev)	<b>L:</b> Foot Mtg.			<b>R:</b> Clockwise (Normal) <sup>*1</sup>		<b>60</b>	
<b>A145</b> (145 cm <sup>3</sup> /rev)						<b>60</b>	

- ★ 1. Available to supply pump with anti-clockwise rotation. Consult Yuken for details.
- ★ 2. Design Standards: None..... Japanese Standard "JIS"  
80 ..... European Design Standard  
950 ..... N. American Design Standard

- ★ 3. When A10 pump is used as the foot Mtg., order the Mtg. Bracket kit shown below separately. Refer to page 24 for dimensions of the Mtg. bracket.  
Note: The mounting bracket kit consists of a mounting bracket, two hex. bolts and two plain washer.

Mtg. Bracket Kit Numbers	Approx. Mass kg (lbs.)
LP-1A-10	2.2 (4.9)

- ★ 4. The pressure adjustment range "B" is not available to the European Design Standard and the N. American Design Standard of "A10".

**Pipe Flange Kits**

Pipe flange kits are available. When ordering, specify the kit number from the table below.

Pump Model Numbers	Name of Port	Pipe Flange Kit Numbers						
		Threaded Connection			Socket Welding <sup>*1</sup>		Butt Welding	
		Japanese Std. "JIS"	European Design Std.	N. American Design Std. <sup>*2</sup>	Japanese Std. "JIS" European Design Std.	N. American Design Std. <sup>*2</sup>	Japanese Std. "JIS" European Design Std.	N. American Design Std. <sup>*2</sup>
A16-*R-01	Suction	F5-06-A-10	F5-06-A-1080	—	F5-06-B-10	F5-06-B-1090	F5-06-C-10	F5-06-C-1090
A22-*R-01	Discharge	F5-06-A-10	F5-06-A-1080	—	F5-06-B-10	F5-06-B-1090	F5-06-C-10	F5-06-C-1090
A37-*R-01	Suction	F5-10-A-10	F5-10-A-1080	—	F5-10-B-10	F5-10-B-1090	F5-10-C-10	F5-10-C-1090
A56-*R-01	Discharge	F5-10-A-10	F5-10-A-1080	—	F5-10-B-10	F5-10-B-1090	F5-10-C-10	F5-10-C-1090
A70-*R01	Suction	F5-12-A-10	F5-12-A-1080	—	F5-12-B-10	F5-12-B-1090	F5-12-C-10	F5-12-C-1090
	Discharge	F5-08-A-10	F5-08-A-1080	—	F5-08-B-10	F5-08-B-1090	F5-08-C-10	F5-08-C-1090
A90-*R01	Suction	F5-16-A-10	F5-16-A-1080	—	F5-16-B-10	F5-16-B-1090	F5-16-C-10	F5-16-C-1090
A145-*R01	Discharge	F5-10-A-10	F5-10-A-1080	—	F5-10-B-10	F5-10-B-1090	F5-10-C-10	F5-10-C-1090

- ★ 1. In case of using socket welding flanges, there is a case where the operating pressure should be set lower than the normal because of strength of the flanges. Therefore, please pay cautious attention to the operating pressure when the socket welding flanges are used.
- ★ 2. As dimensions of the pipe flange mounting surface are conformed to SAE 4 Bolt Split Flange (Standard Pressure Series), pipe flanges conforming to the SAE Standards can be used.
- Details of the pipe flange kits are shown on page 824.



### Response Characteristics Change in Accordance with Circuits and Operating Conditions.

#### Test Circuit and Conditions

##### Circuit

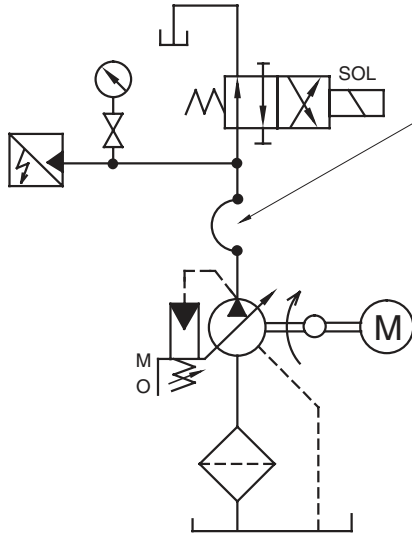

##### Conditions

- Drive Speed : 1500 r/min
- Hydraulic Fluid : ISO VG32 oil
- Oil Temperature : A10-A56: 50 °C (122 °F) [Viscosity 20 mm<sup>2</sup>/s (100 SSU)]  
A70-A145: 40 °C (104 °F) [Viscosity 32 mm<sup>2</sup>/s (150 SSU)]

#### High Pressure Rubber Hose

Model	Ruber Hose Size
A10	1/2" × 800 mm (2.6 ft.)
A16 A22	3/4" × 700 mm (2.3 ft.)
A37 A56	3/4" × 2000 mm (6.6 ft.)
A70	3/4" × 3500 mm (11.5 ft.)
A90 A145	3/4" × 3000 mm (9.8 ft.) + 1-1/4" × 2000 mm (6.6 ft.)

#### Result of Measurement

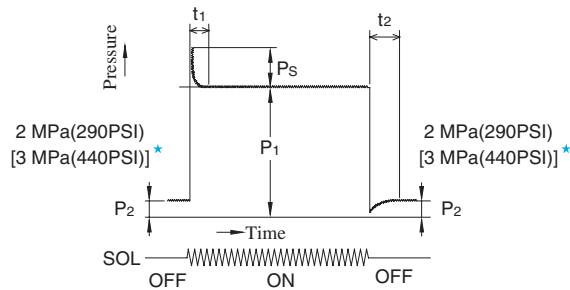

★ Applicable only for "A90/A145"

Model	Full Cut-off Pressure P <sub>1</sub> MPa (PSI)	Response Time ms		Overshoot Pressure P <sub>s</sub> MPa (PSI)
		t <sub>1</sub>	t <sub>2</sub>	
A10	21 (3050)	100	75	2.6 (380)
A16	16 (2320)	38*	59*	3.6 (520)
A22	16 (2320)	30*	72*	5.9 (860)
A37	16 (2320)	40*	78*	7.8 (1130)
A56	16 (2320)	38*	88*	7.6 (1100)
A70	25 (3630)	80	100	7.8 (1130)
A90	25 (3630)	90	110	7.9 (1150)
A145	25 (3630)	100	150	8.8 (1280)

\* Response time except A10, A70, A90 and A145 is measured Yoke travel.

Typical Performance Characteristics of Type "A10" at Viscosity 20 mm<sup>2</sup>/s (100 SSU) [ISO VG32 Oils, 50°C (122°F)]

■ Performance Characteristic Curve

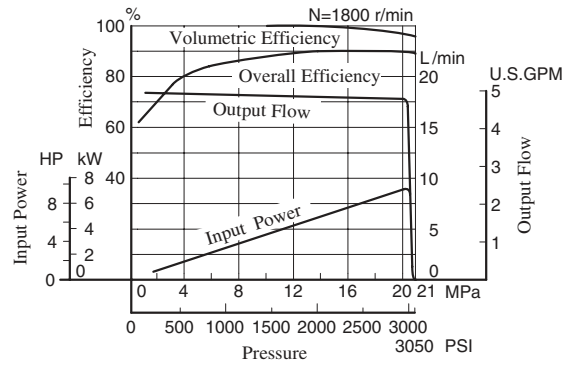
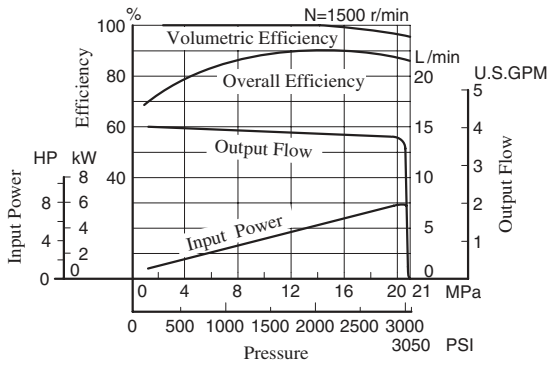

■ Input Power

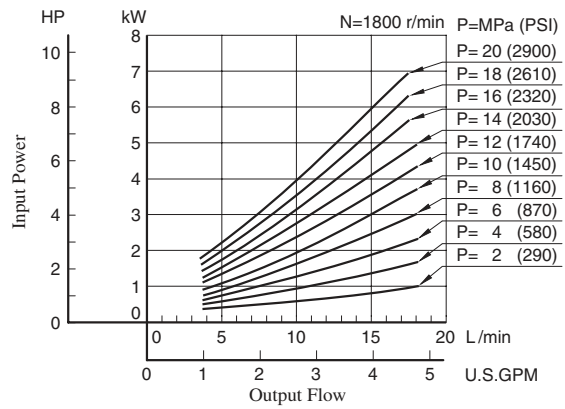
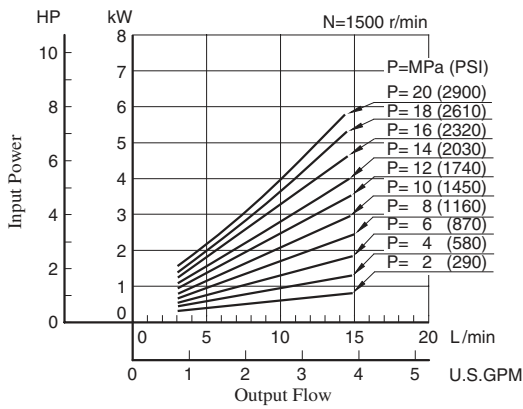

■ Full Cut-off Power

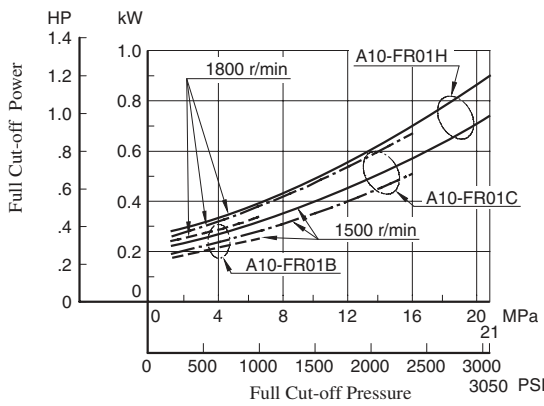

■ Drain

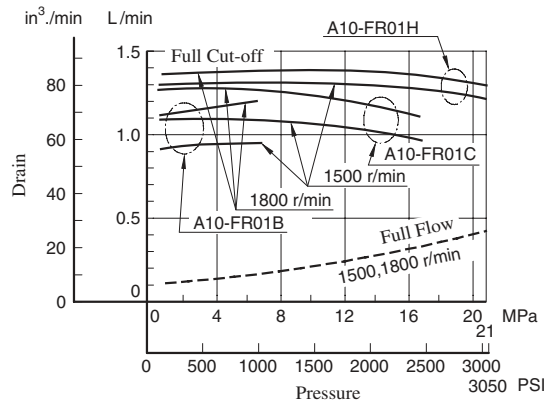

■ Noise Level [One metre (3.3 ft.) horizontally away from pump head cover]

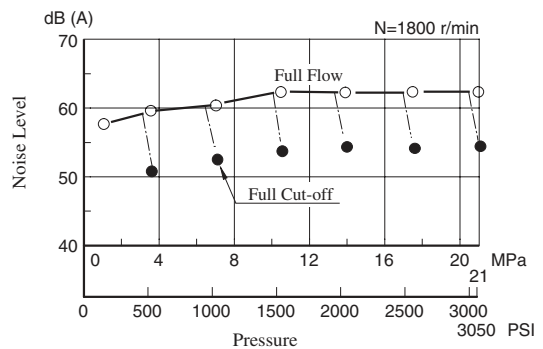
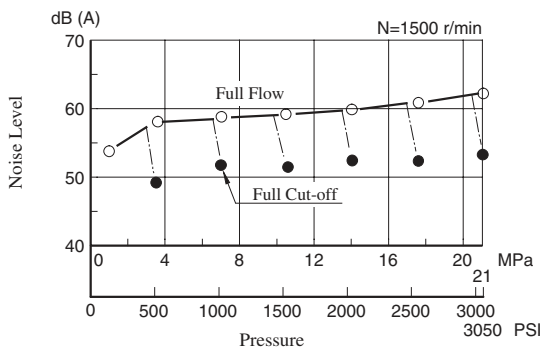





Typical Performance Characteristics of Type "A16" at Viscosity 20 mm<sup>2</sup>/s (100 SSU) [ISO VG32 Oils, 50°C (122°F)]

### Performance Characteristic Curve

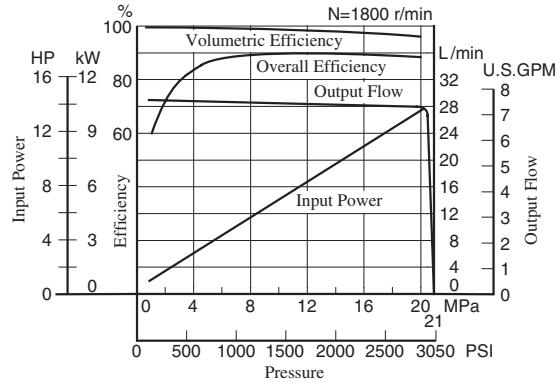
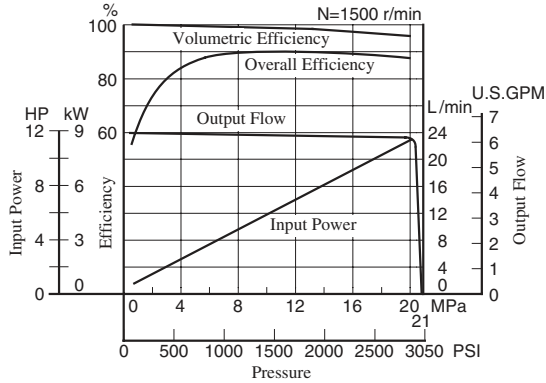

### Input Power

Example: At a pressure of under 10 MPa (1450 PSI), a flow 20 L/min (5.3 U.S.GPM), and rotation 1500 r/min, the axial input becomes about 3.7 kW (5 HP) as shown the dotted line in the graph.

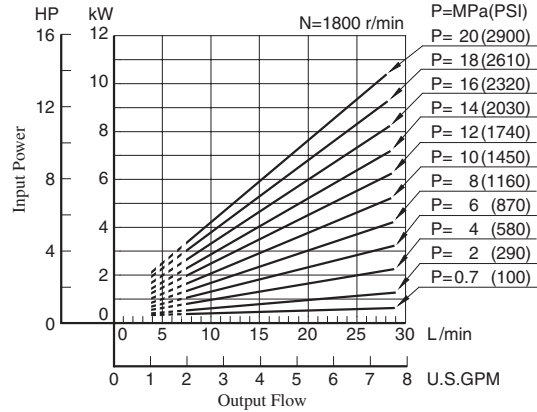
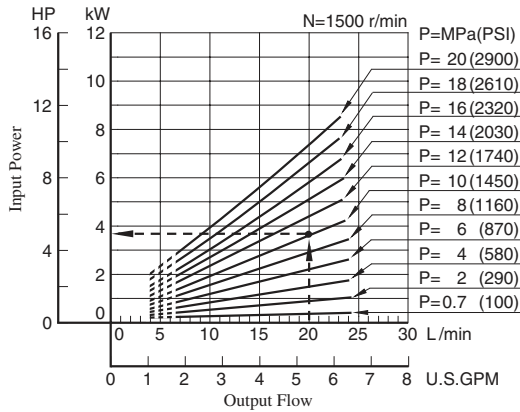

### Full Cut-off Power

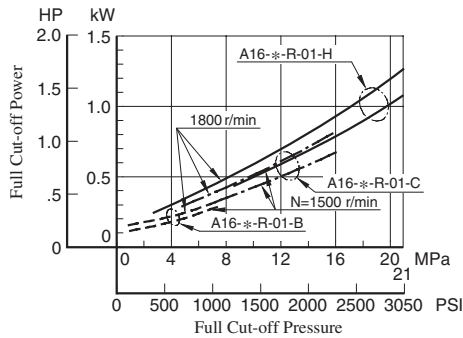

### Drain

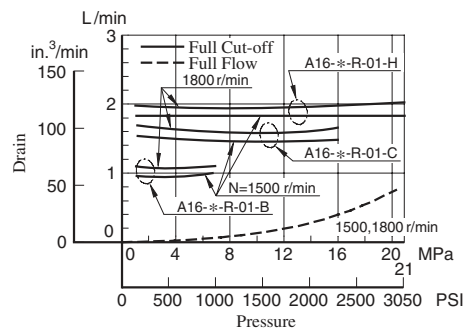

### Noise Level [One metre (3.3 ft.) horizontally away from pump head cover]

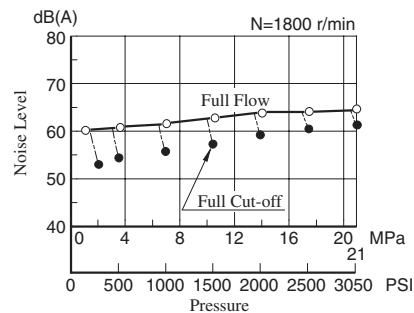
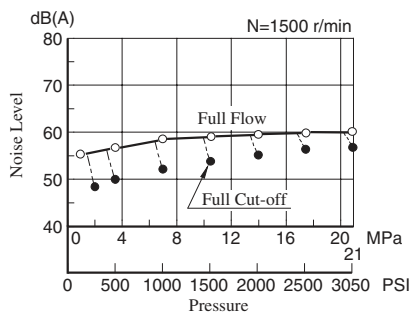

Typical Performance Characteristics of Type "A22" at Viscosity 20 mm<sup>2</sup>/s (100 SSU) [ISO VG32 Oils, 50°C (122°F)]

■ Performance Characteristic Curve

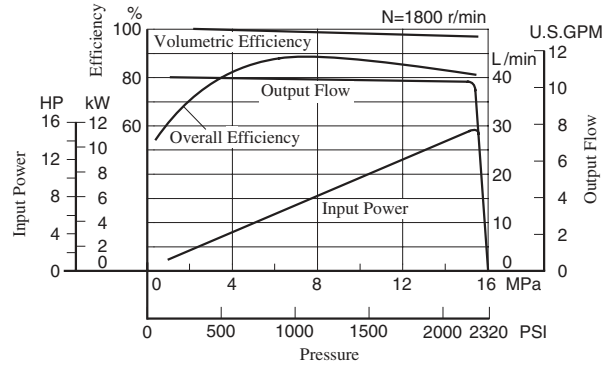
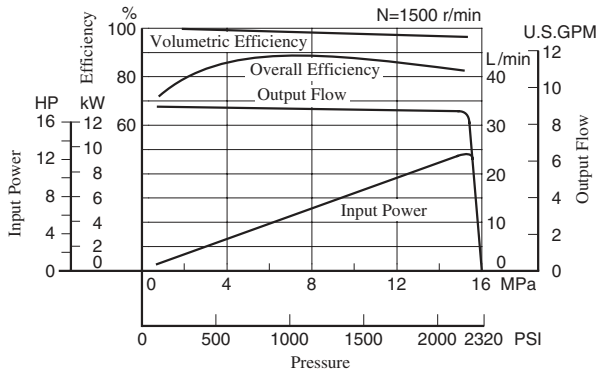

■ Input Power

Example: At a pressure of under 10 MPa (1450 PSI), a flow 30 L/min (7.9 U.S.GPM), and rotation 1500 r/min, the axial input becomes about 5.4 kW (7.2 HP) as shown the dotted line in the graph.

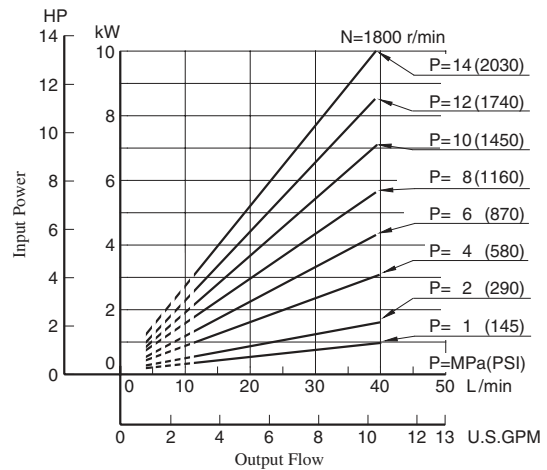
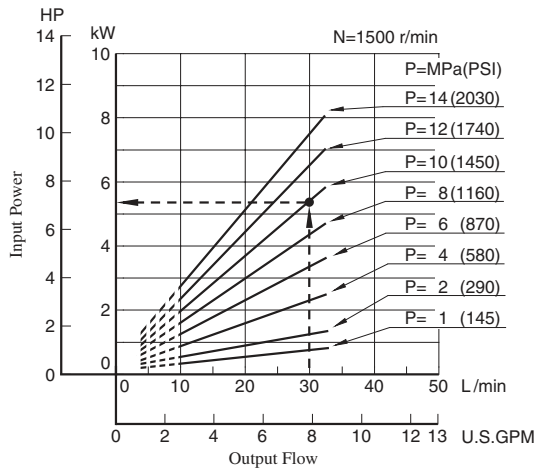

■ Full Cut-off Power

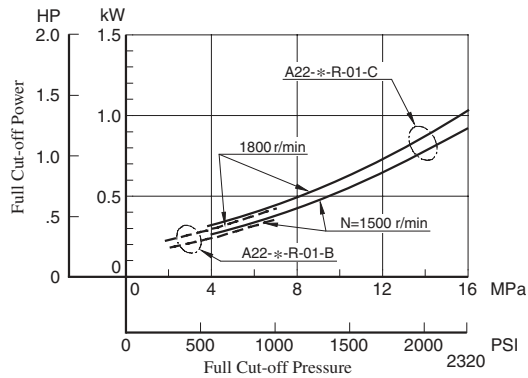

■ Drain

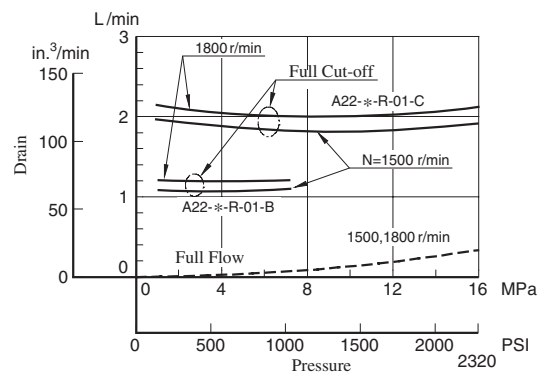

■ Noise Level [One metre (3.3 ft.) horizontally away from pump head cover]

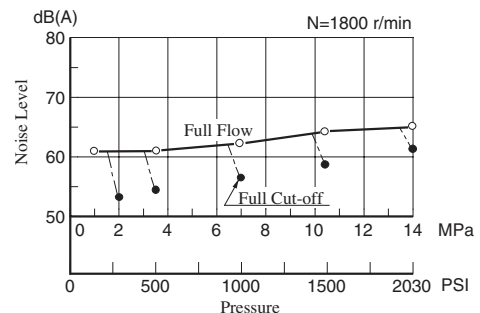
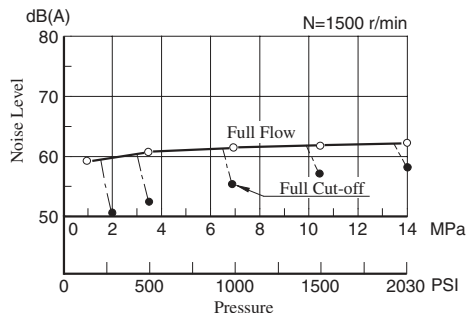



Typical Performance Characteristics of Type "A37" at Viscosity 20 mm<sup>2</sup>/s (100 SSU) [ISO VG32 Oils, 50°C (122°F)]

## Performance Characteristic Curve

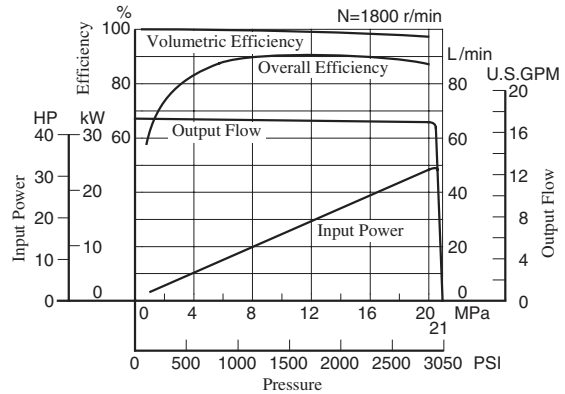
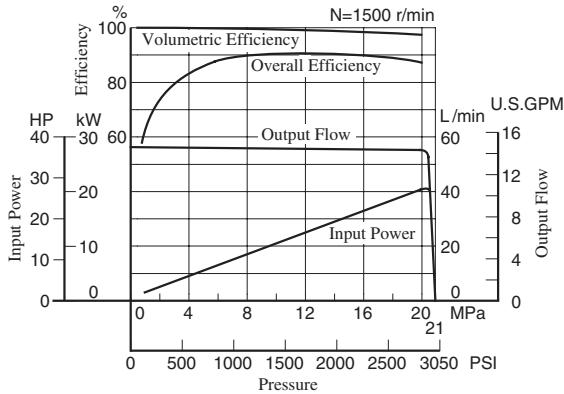

## Input Power

Example: At a pressure of under 16 MPa (2320 PSI), a flow 45 L/min (11.9 U.S.GPM), and rotation 1500 r/min, the axial input becomes about 12.6 kW (16.9 HP) as shown the dotted line in the graph.

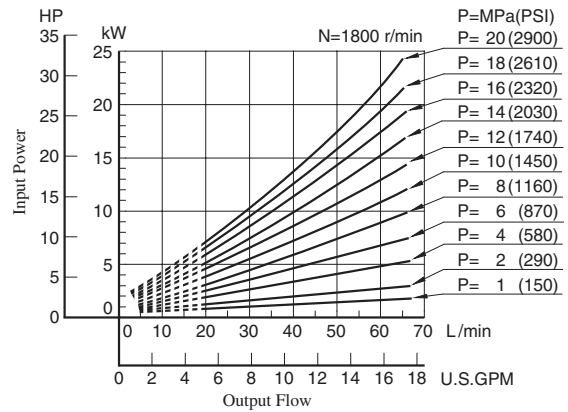
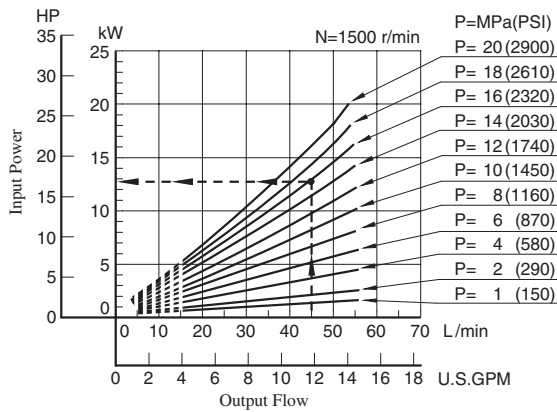

## Full Cut-off Power

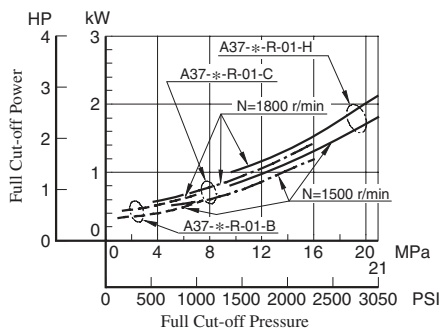

## Drain

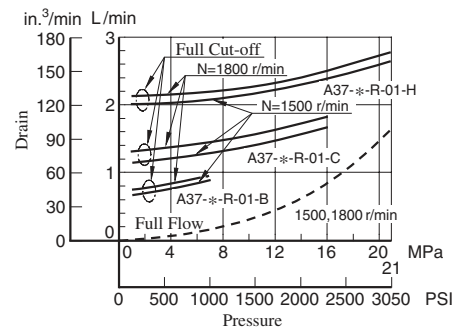

## Noise Level [One metre (3.3 ft.) horizontally away from pump head cover]

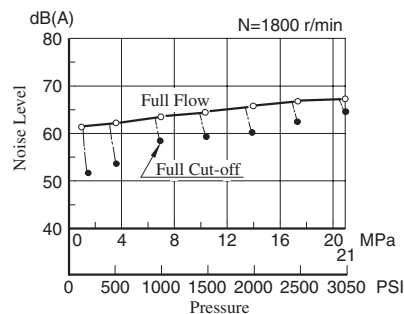
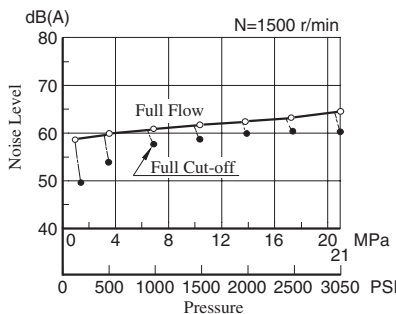

Typical Performance Characteristics of Type "A56" at Viscosity 20 mm<sup>2</sup>/s (100 SSU) [ISO VG32 Oils, 50°C (122°F)]

■ Performance Characteristic Curve

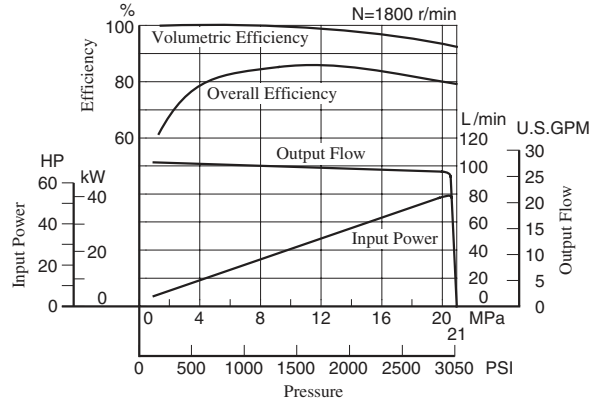
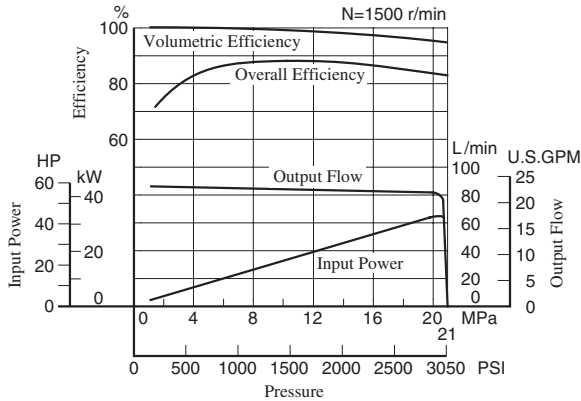

■ Input Power

Example: At a pressure of under 16 MPa (2320 PSI), a flow 70 L/min (18.5 U.S.GPM), and rotation 1500 r/min, the axial input becomes about 20.8 kW (27.9 HP) as shown the dotted line in the graph.

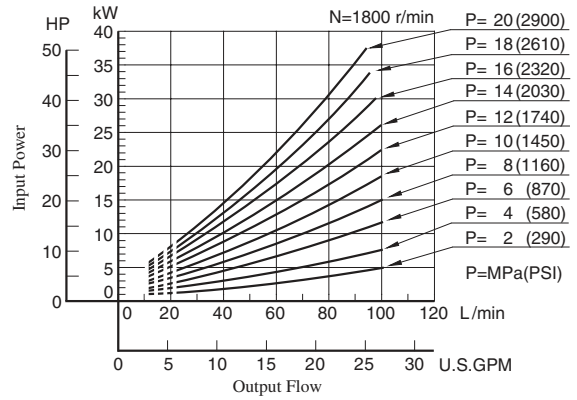
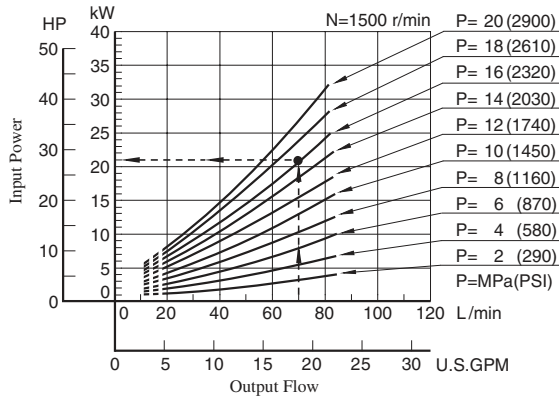

■ Full Cut-off Power

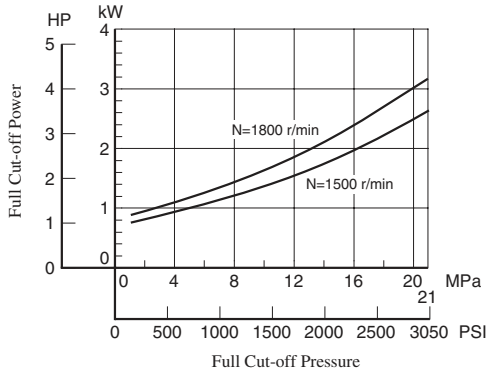

■ Drain

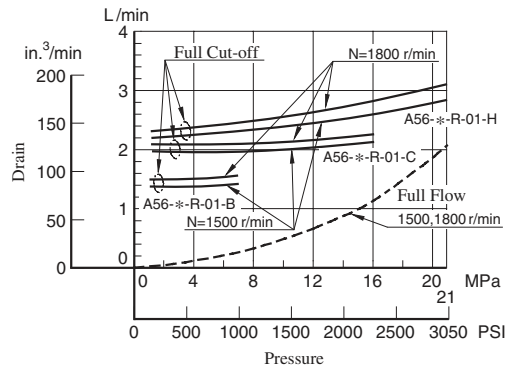

■ Noise Level [One metre (3.3 ft.) horizontally away from pump head cover]

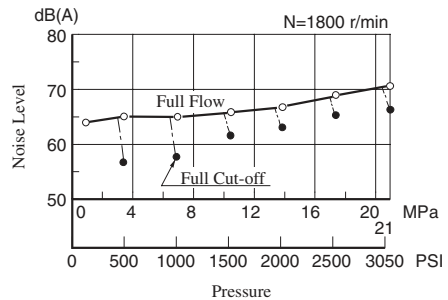
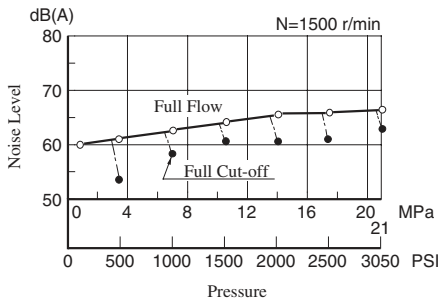



Typical Performance Characteristics of Type "A70" at Viscosity 32 mm<sup>2</sup>/s (150 SSU) [ISO VG32 Oils, 40°C (104°F)]

### Performance Characteristics Curve

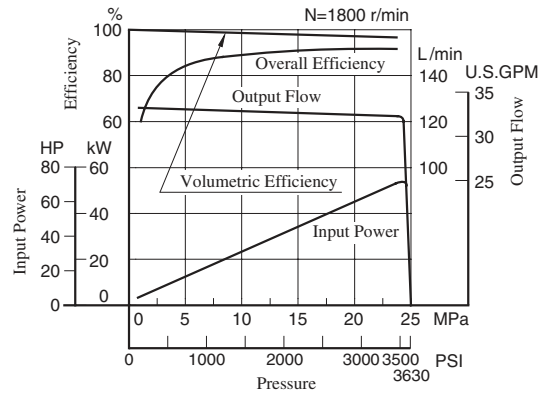
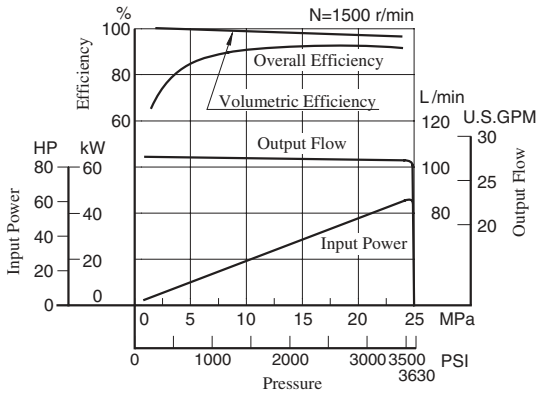

### Input Power

Example: At a pressure of under 20 MPa (2900 PSI), a flow 70 L/min (18.5 U.S.GPM), and rotation 1500 r/min, the axial input becomes about 26 kW (35 HP) as shown the dotted line in the graph.

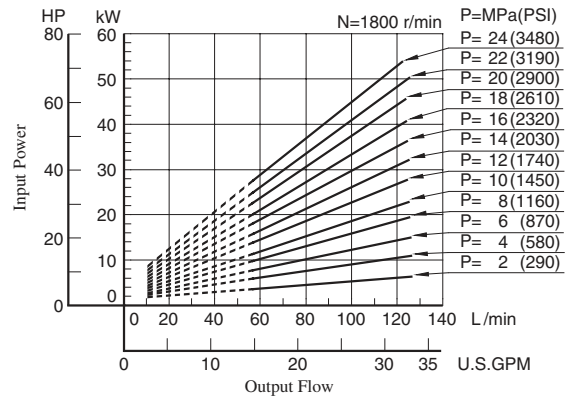
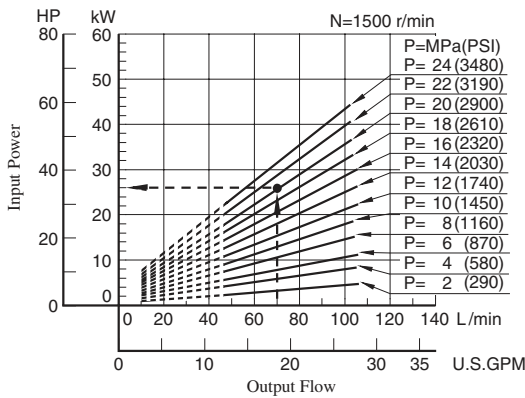

### Full Cut-off Power

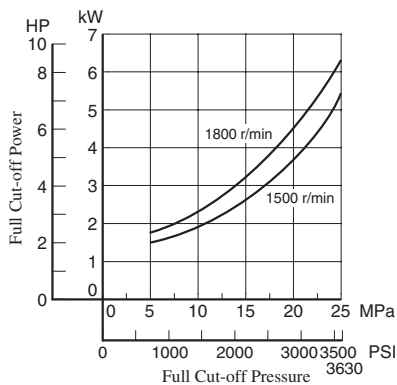

### Drain

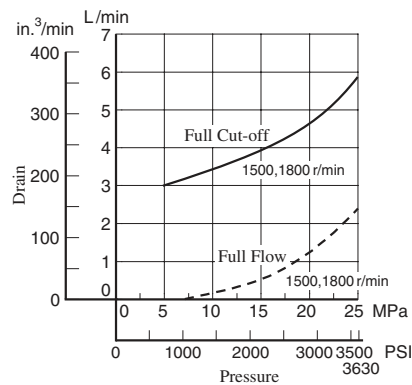

### Noise Level [One metre (3.3 ft.) horizontally away from pump head cover]

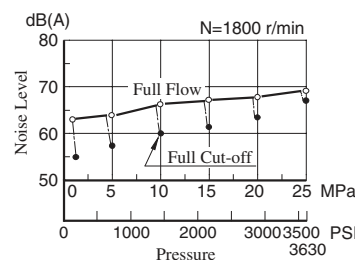
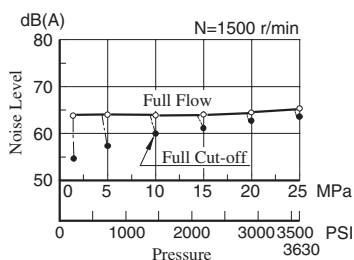

Typical Performance Characteristics of Type "A90" at Viscosity 32 mm<sup>2</sup>/s (150 SSU) [ISO VG32 Oils, 40°C (104°F)]

■ Performance Characteristics Curve

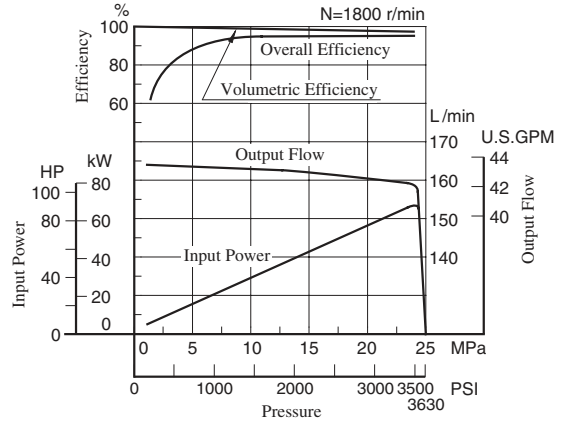
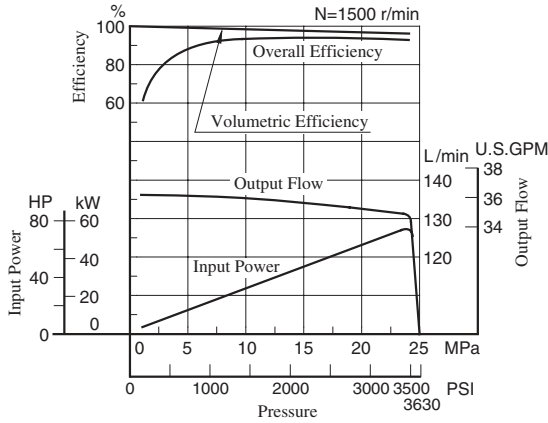

■ Input Power

Example: At a pressure of under 18 MPa (2610 PSI), a flow 110 L/min (29.1 U.S.GPM), and rotation 1500 r/min, the axial input becomes about 34 kW (46 HP) as shown the dotted line in the graph.

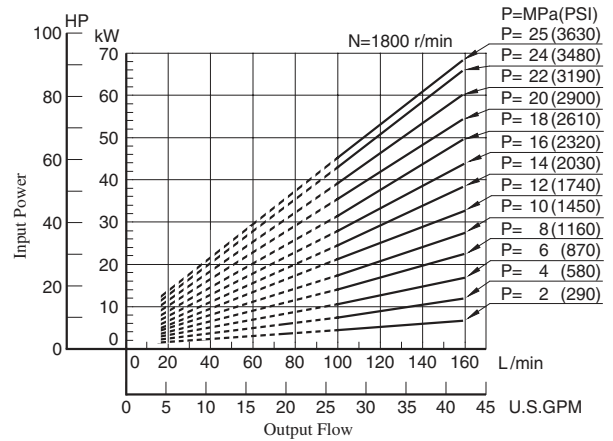
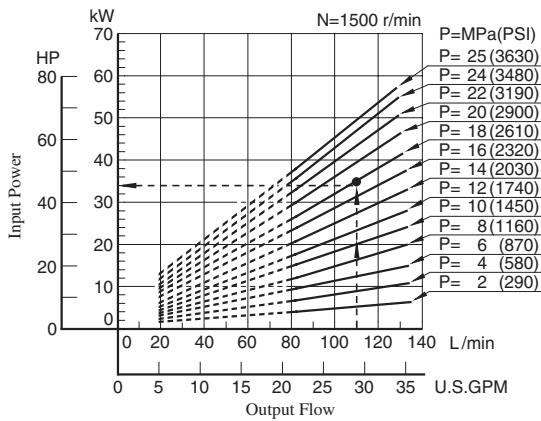

■ Full Cut-off Power

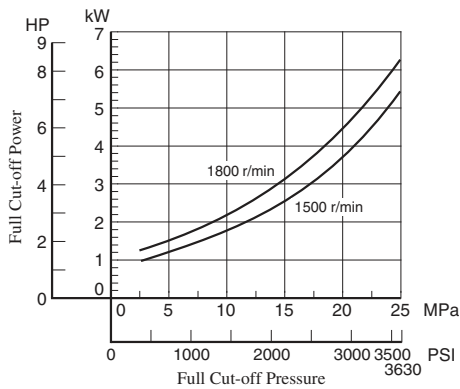

■ Drain

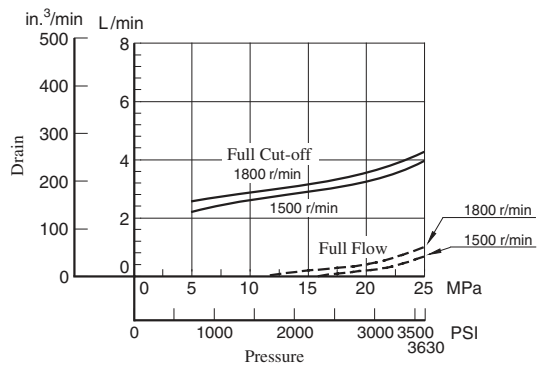

■ Noise Level [One metre (3.3 ft.) horizontally away from pump head cover]

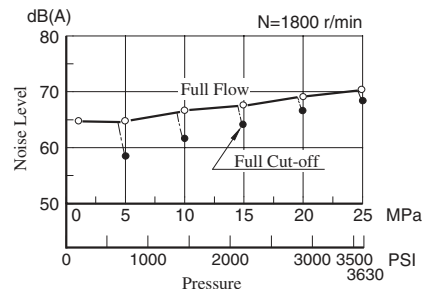
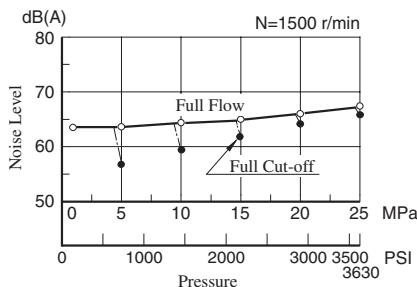



### Typical Performance Characteristics of Type "A145" at Viscosity 32 mm<sup>2</sup>/s (150 SSU) [ISO VG32 Oils, 40°C (104°F)]

#### Performance Characteristics Curve

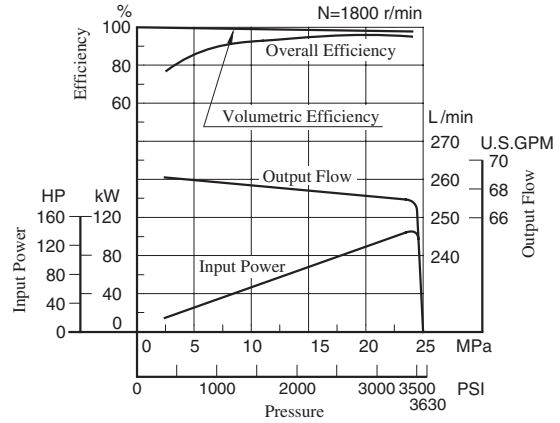
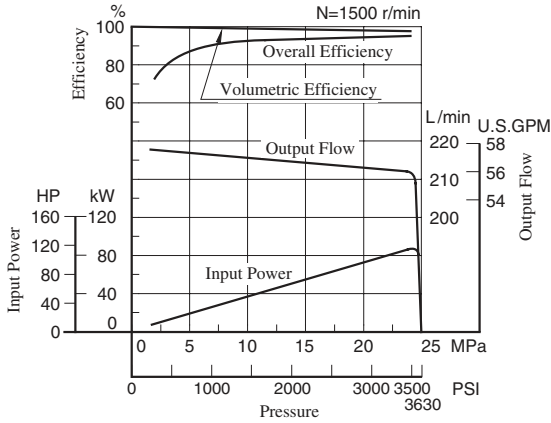

#### Input Power

Example: At a pressure of under 20 MPa (2900 PSI), a flow 180 L/min (47.6 U.S.GPM), and rotation 1500 r/min, the axial input becomes about 64 kW (86 HP) as shown the dotted line in the graph.

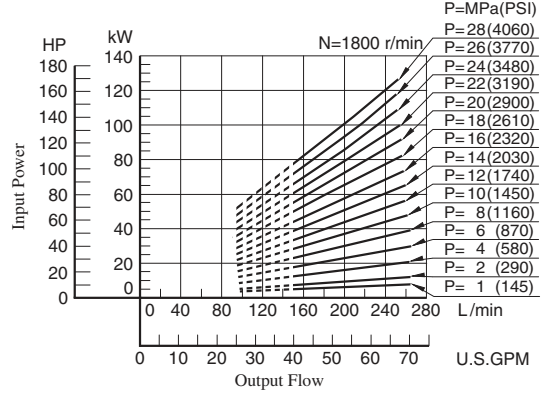
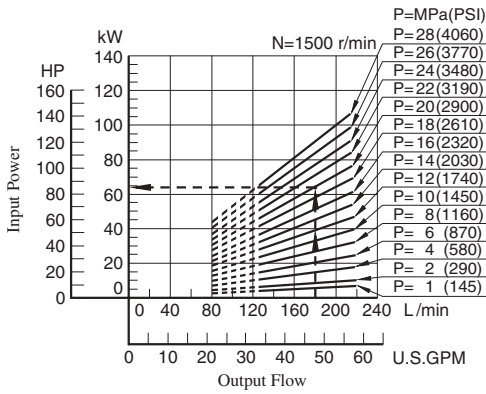

#### Full Cut-off Power

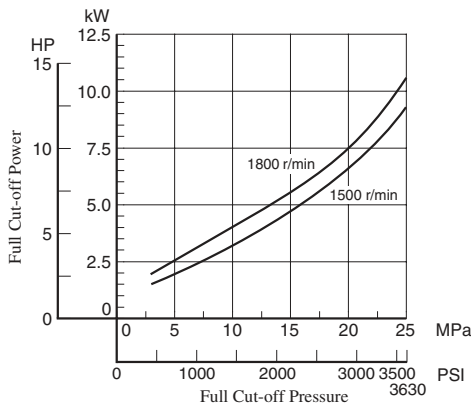

#### Drain

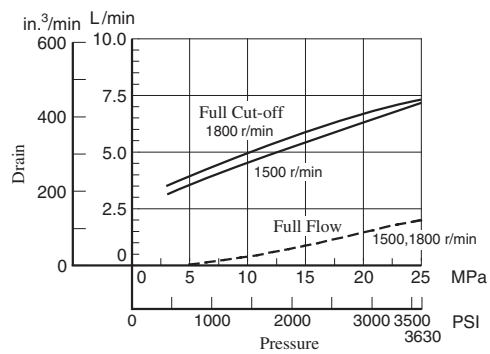

#### Noise Level [One metre (3.3 ft.) horizontally away from pump head cover]

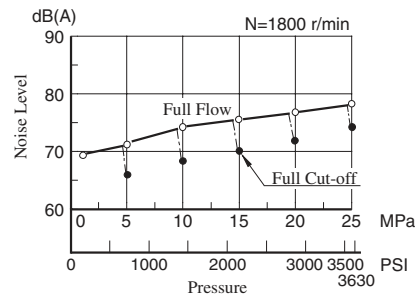
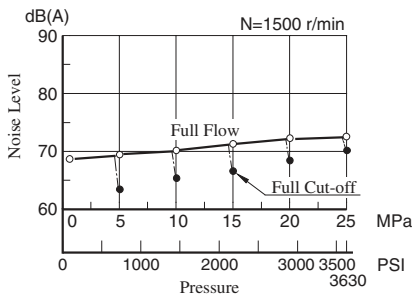

**Flange Mtg.**

**DIMENSIONS IN MILLIMETRES (INCHES)**

**Pressure Adjustment Range "C" & "H"**

- **Japanese Standard "JIS": A10-FR01-C/H-12**

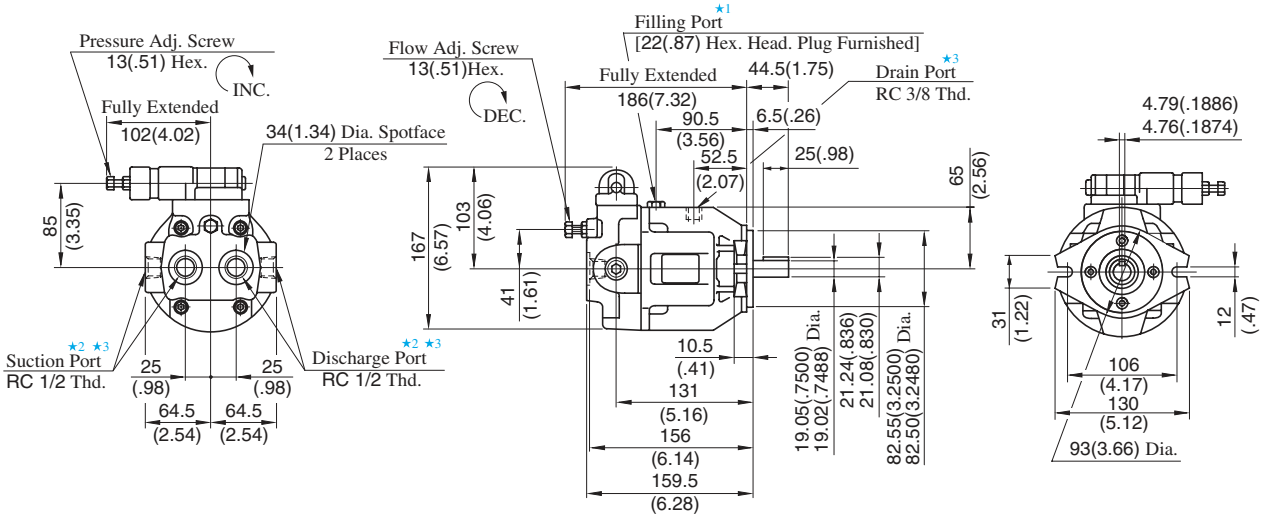

- **European Design Standard: A10-FR01-C/H-1280**
- **N. American Design Standard: A10-FR01-C/H-12950**

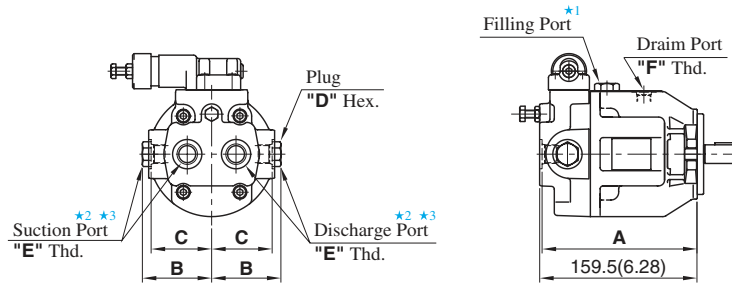

Model Numbers	Dimensions mm(Inches)				Thread Size	
	A	B	C	D	E	F
A10-FR01C/H-1280	159 (6.25)	72 (2.83)	64 (2.52)	27 (1.06)	1/2 BSP. F	3/8 BSP. F
A10-FR01C/H-12950	157 (6.18)	71 (2.80)	62 (2.44)	22 (.87)	SAE #8	SAE #6

● For other dimensions, refer to Japanese Standard "JIS".

**Pressure Adjustment Range "B"**

- **Japanese Standard "JIS": A10-FR01-B-12**

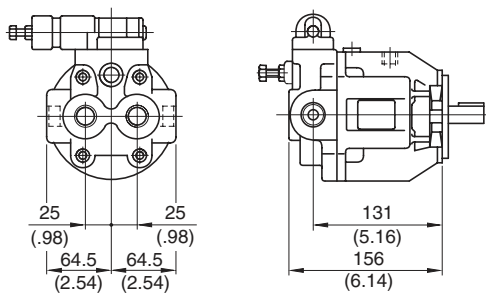

● For other dimensions, refer to above Pressure Adj. Range "C" & "H".

- ★ 1. Install the pump so that the "Filling Port" is at the top.
- ★ 2. Use either port of two suction and discharge ports at your option. Keep the remaining ports plugged.
- ★ 3. As the tightening torques of suction, discharge and drain port fittings, conform to the below.

Model Numbers	Tightening Torque Nm(IN. lbs.)	
	Suction Port & Discharge Port	Drain Port
A10-FR01B/C/H-12	65-75 (575-664)	40-50 (354-443)
A10-FR01C/H-1280	56-62 (496-549)	33-36 (292-319)
A10-FR01C/H-12950	47-51 (363-451)	40-50 (354-443)



Axial Port Type

Flange Mtg.: A16-F-R-01-\*-K-32/3280/32950  
A22-F-R-01-\*-K-32/3280/32950

Model Numbers	"C" Thd.	"D" Thd.
A16/A22-F-R-01-*-K-32	Rc 3/8	M 10
A16/A22-F-R-01-*-K-3280	3/8 BSP.F	
A16/A22-F-R-01-*-K-3290	SAE #8	3/8-16 UNC

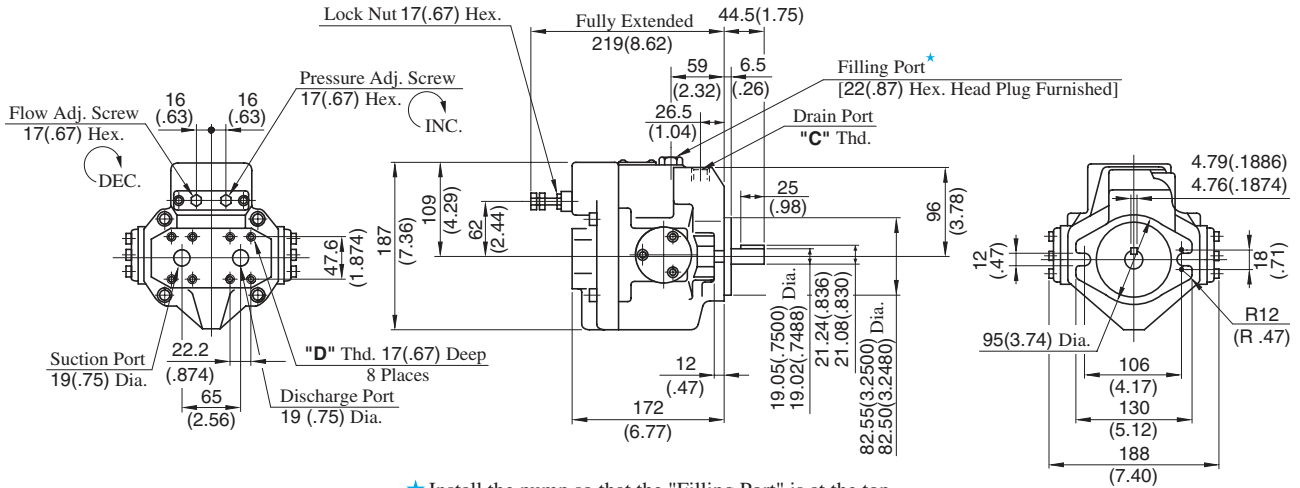

Foot Mtg.: A16-L-R-01-\*-K-32/3280/32950  
A22-L-R-01-\*-K-32/3280/32950

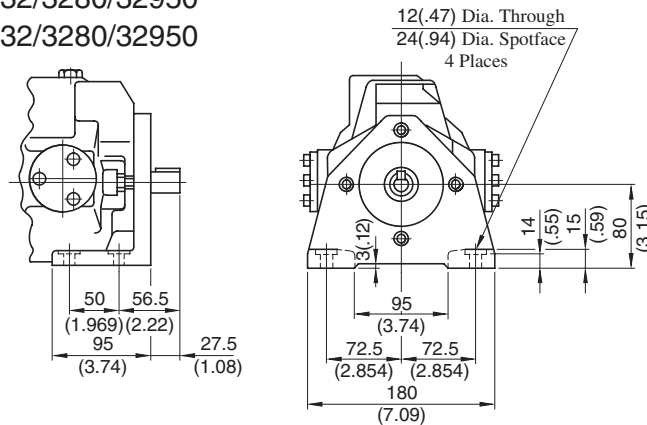

• For other dimensions, refer to "Flange Mtg.".

Side Port Type

DIMENSIONS IN MILLIMETRES (INCHES)

Flange Mtg.: A16-F-R-01-\*-S-K-32/3280/32950  
A22-F-R-01-\*-S-K-32/3280/32950

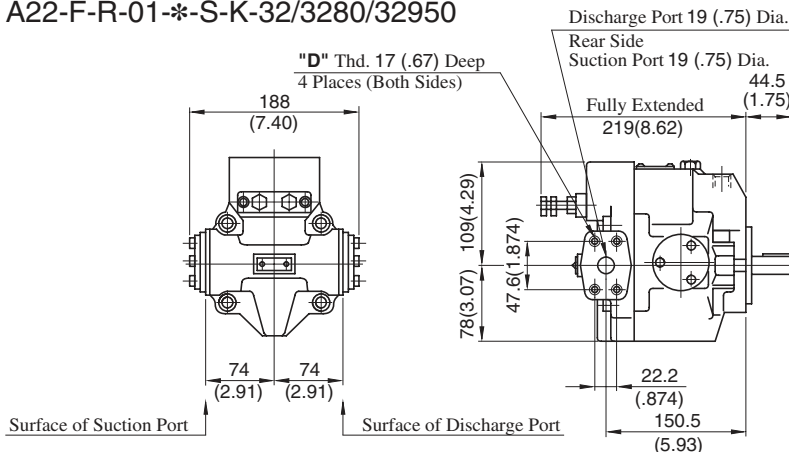

• For other dimensions, refer to "Axial Port Type".  
• Foot Mtg. Type; Mounting bracket is common to that of "Axial Port Type".

**Axial Port Type**

Flange Mtg.: A37-F-R-01-\*-K-32/3280/32950

Model Numbers	"C" Thd.	"D" Thd.	E mm (IN.)
A37-F-R-01-*-K-32	Rc 1/2	M 10	19 (.75)
A37-F-R-01-*-K-3280	1/2 BSP.F		
A37-F-R-01-*-K-32950	SAE #10	7/16-14 UNC	20 (.79)

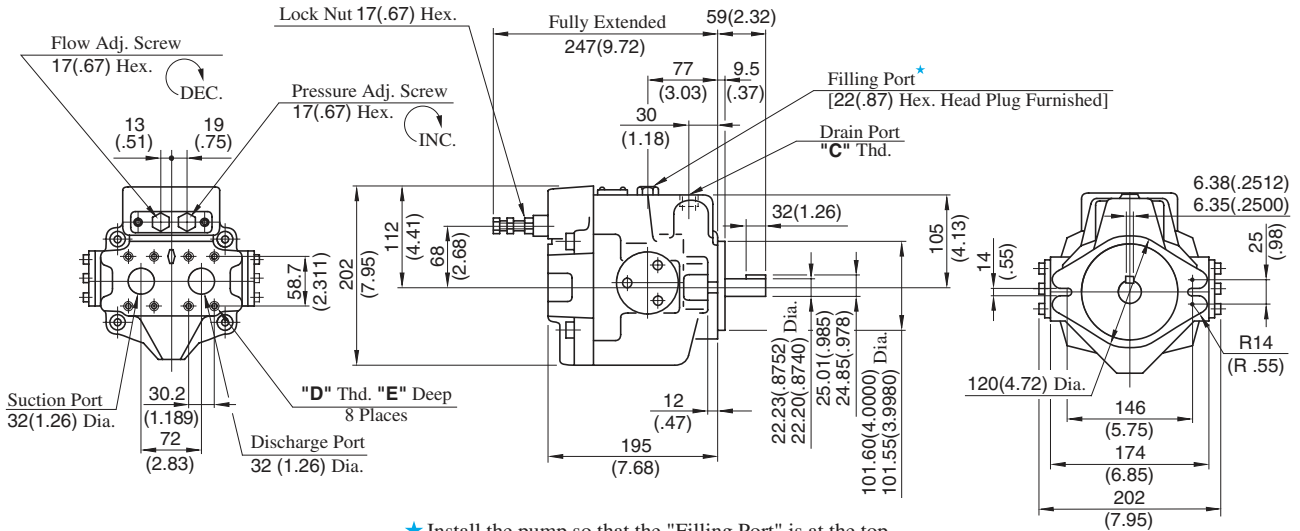

Foot Mtg.: A37-L-R-01-\*-K-32/3280/32950

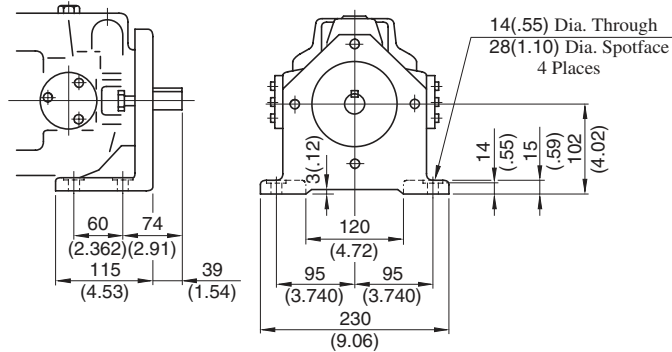

• For other dimensions, refer to "Flange Mtg.".

**Side Port Type**

**DIMENSIONS IN MILLIMETRES (INCHES)**

Flange Mtg.: A37-F-R-01-\*-S-K-32/3280/32950

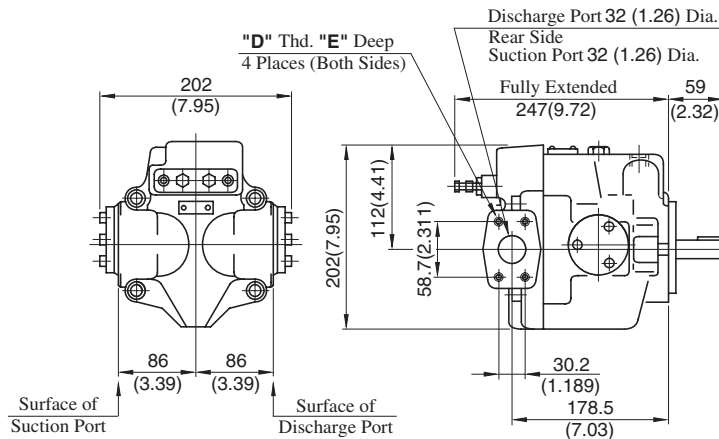

• For other dimensions, refer to "Axial Port Type".  
 • Foot Mtg. Type; Mounting bracket is common to that of "Axial Port Type".

Axial Port Type

Flange Mtg.: A56-F-R-01-\*-K-32/3280/32950

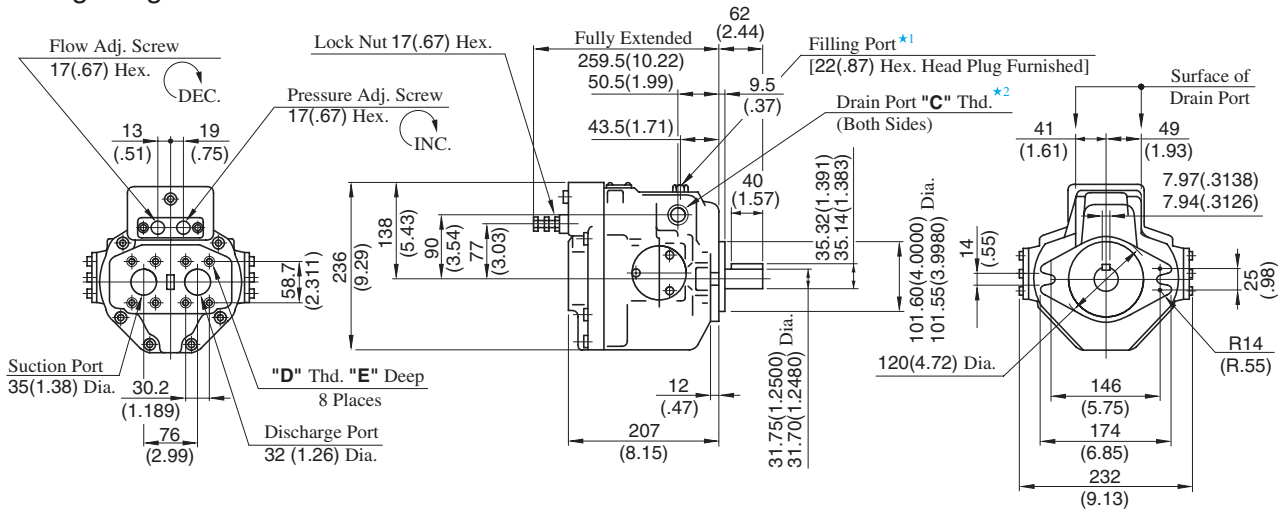

Model Numbers	"C" Thd.	"D" Thd.	E mm (IN.)
A56-F-R-01-*-K-32	Rc 3/4	M 10	19 (.75)
A56-F-R-01-*-K-3280	3/4 BSP.F	M 10	19 (.75)
A56-F-R-01-*-K-32950	SAE #12	7/16-14 UNC	20 (.79)

- \*1. Install the pump so that the "Filling Port" is at the top.
- \*2. Use either port of the two drain ports at your option. Keep the remaining port plugged.

Foot Mtg.: A56-L-R-01-\*-K-32/3280/32950

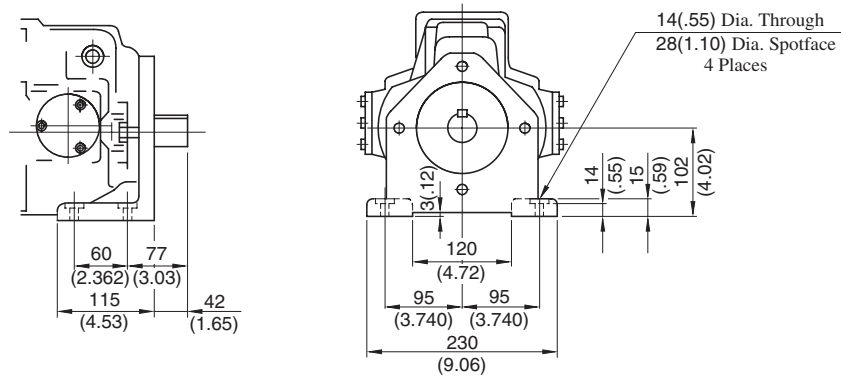

• For other dimensions, refer to "Flange Mtg.".

Side Port Type

DIMENSIONS IN MILLIMETRES (INCHES)

Flange Mtg.: A56-F-R-01-\*-S-K-32/3280/32950

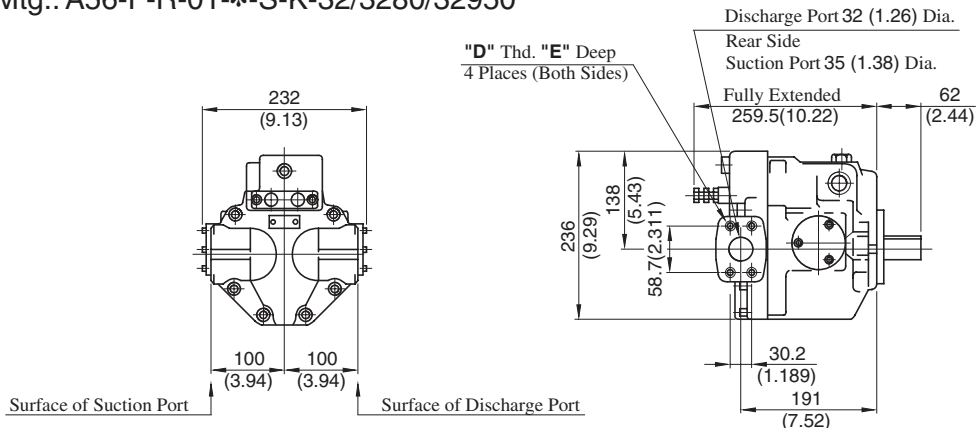

- For other dimensions, refer to "Axial Port Type".
- Foot Mtg. Type; Mounting bracket is common to that of "Axial Port Type".

**Flange Mtg.: A70-FR01\*S-60/6080/60950**

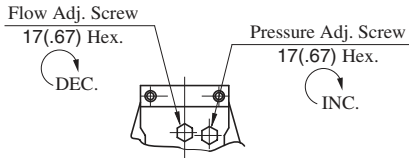
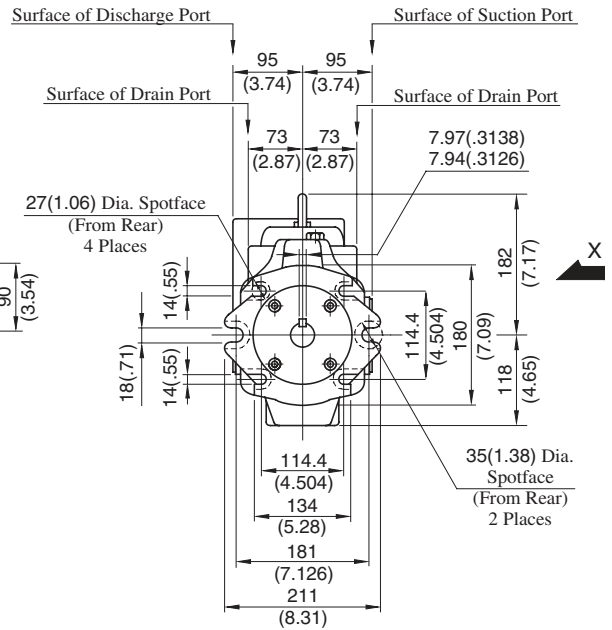
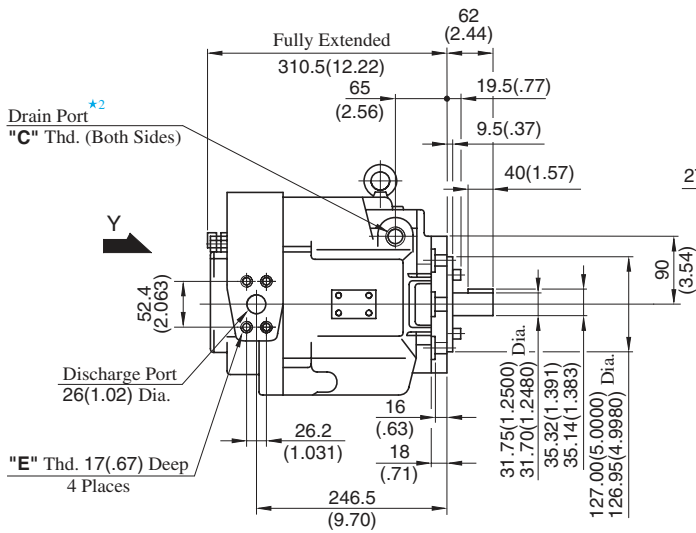

**View Arrow Y**

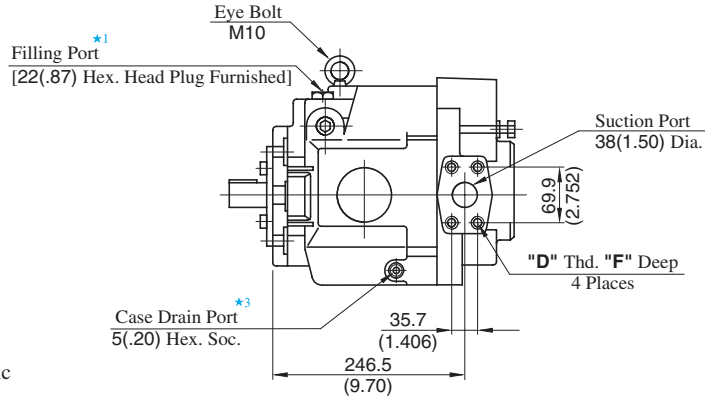

**View Arrow X**

- ★ 1. Install the pump so that the "Filling Port" is at the top.
- ★ 2. Use either port of the two drain ports at your option. Keep the remaining port plugged.
- ★ 3. Case drain port is available for use when draining hydraulic fluid from pump casing.

Model Numbers	"C" Thd.	"D" Thd.	"E" Thd.	F mm (IN.)
A70-FR01*S-60	Rc 3/4	M 12	M 10	19 (.75)
A70-FR01*S-6080	3/4 BSP.F			
A70-FR01*S-60950	SAE #12	1/2-13 UNC	3/8-16 UNC	21 (.83)

**DIMENSIONS IN MILLIMETRES (INCHES)**

**Foot Mtg.: A70-LR01\*S-60/6080/60950**

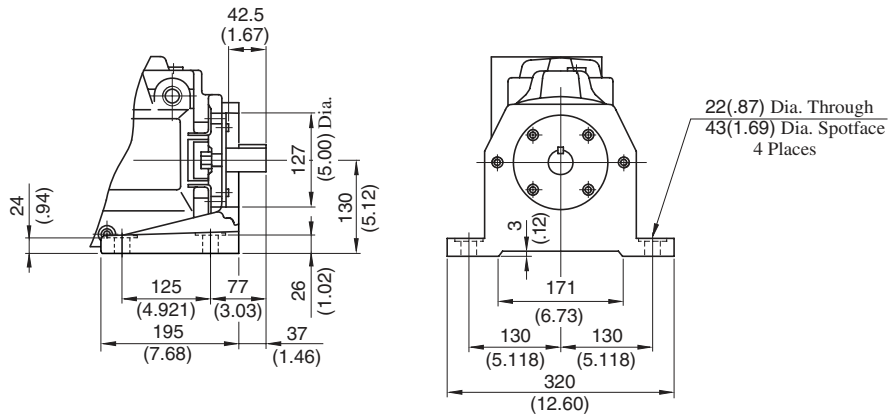

• For other dimensions, refer to "Flange Mtg.".

Flange Mtg.: A90-FR01\*S-60/6080/60950

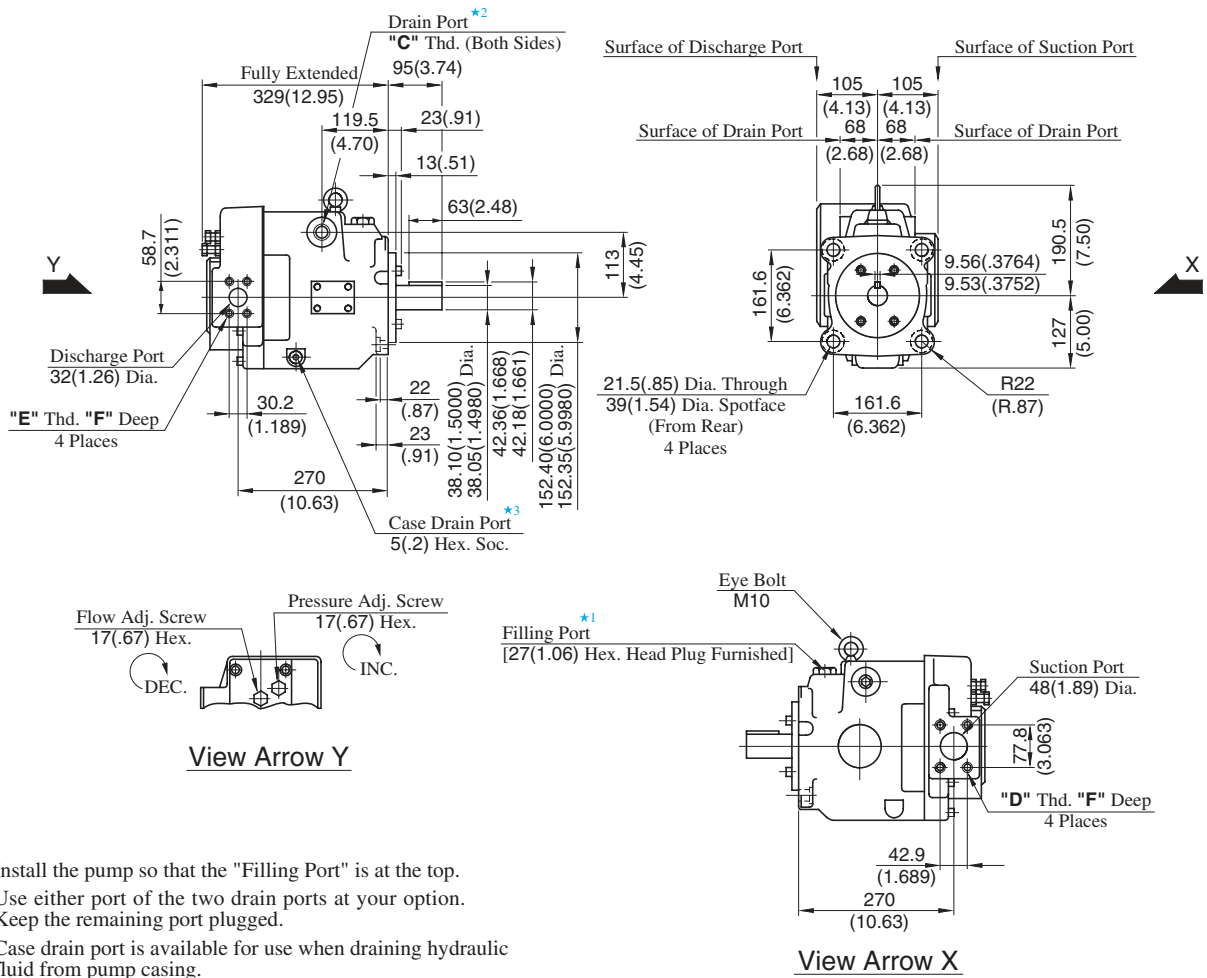

- ★ 1. Install the pump so that the "Filling Port" is at the top.
- ★ 2. Use either port of the two drain ports at your option. Keep the remaining port plugged.
- ★ 3. Case drain port is available for use when draining hydraulic fluid from pump casing.

Model Numbers	"C" Thd.	"D" Thd.	"E" Thd.	F mm (IN.)
A90-FR01*S-60	Rc 3/4	M 12	M 10	19 (.75)
A90-FR01*S-6080	3/4 BSP.F			
A90-FR01*S-60950	SAE #12	1/2-13 UNC	7/16-14 UNC	21 (.83)

DIMENSIONS IN MILLIMETRES (INCHES)

Foot Mtg.: A90-LR01\*S-60/6080/60950

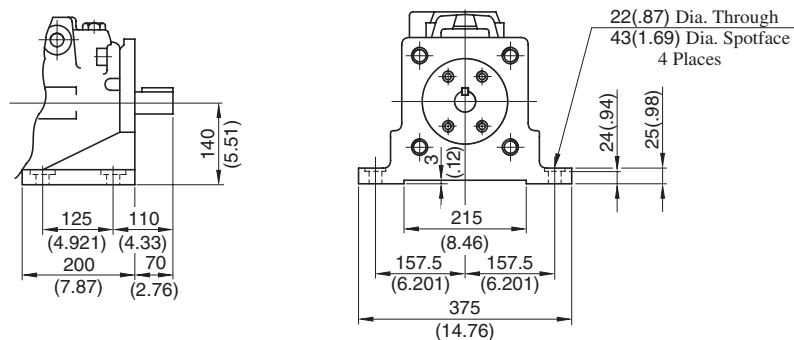

• For other dimensions, refer to "Flange Mtg.".

Flange Mtg.: A145-FR01\*S-60/6080/60950

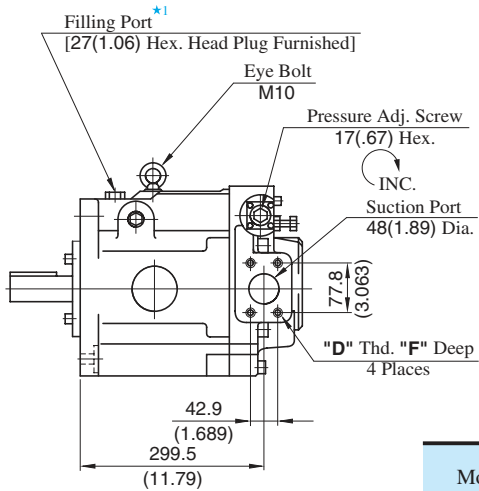
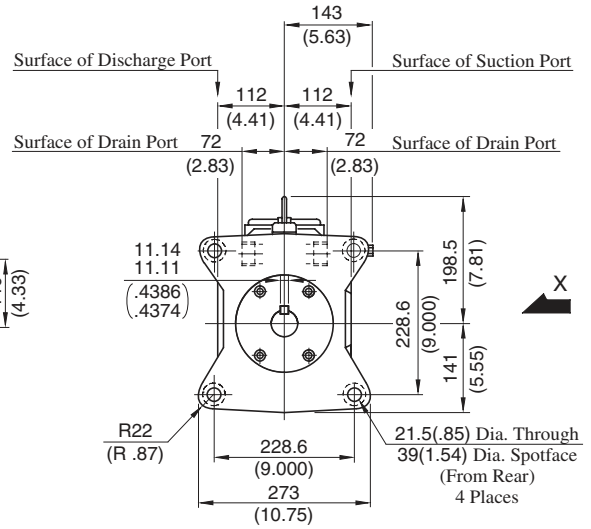
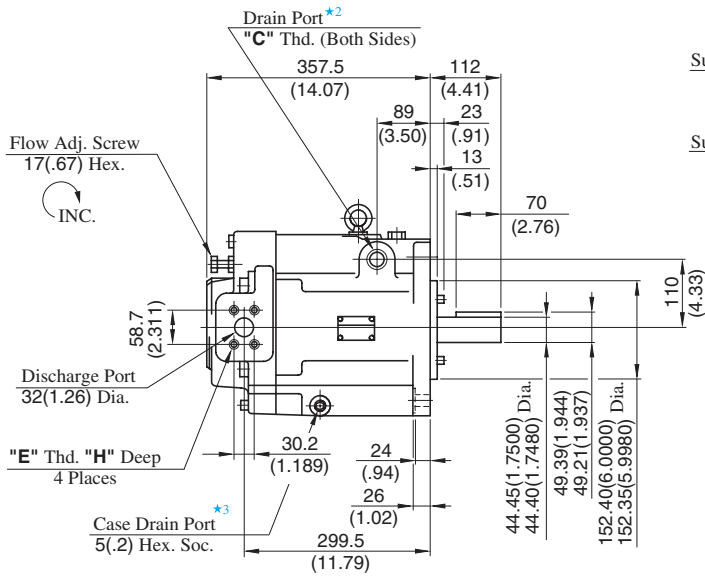

View Arrow X

- ★ 1. Install the pump so that the "Filling Port" is at the top.
- ★ 2. Use either port of the two drain ports at your option. Keep the remaining port plugged.
- ★ 3. Case drain port is available for use when draining hydraulic fluid from pump casing.

Model Numbers	"C" Thd.	"D" Thd.	"E" Thd.	Dimensions mm (IN.)	
				F	H
A145-FR01*S-60	Rc 3/4	M 12	M 10	19 (.75)	19 (.75)
A145-FR01*S-6080	3/4 BSP.F				
A145-FR01*S-60950	SAE #12	1/2-13 UNC	7/16-14 UNC	21 (.83)	20 (.79)

**DIMENSIONS IN MILLIMETRES (INCHES)**

Foot Mtg.: A145-LR01\*S-60/6080/60950

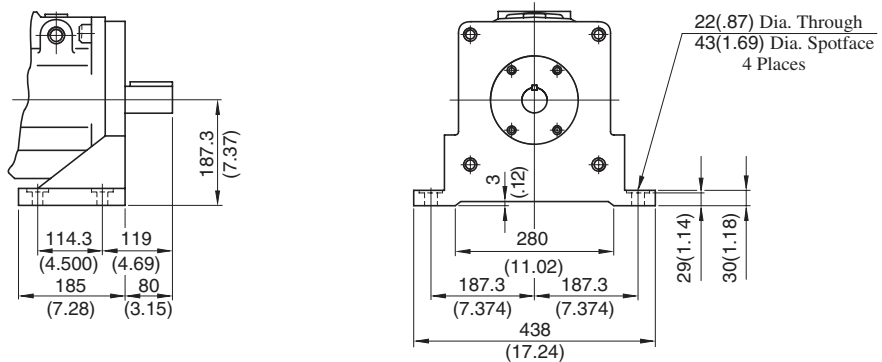

• For other dimensions, refer to "Flange Mtg.".

Spare Parts List

A10-FR01-B-12  
A10-FR01C/H-12/1280/12950

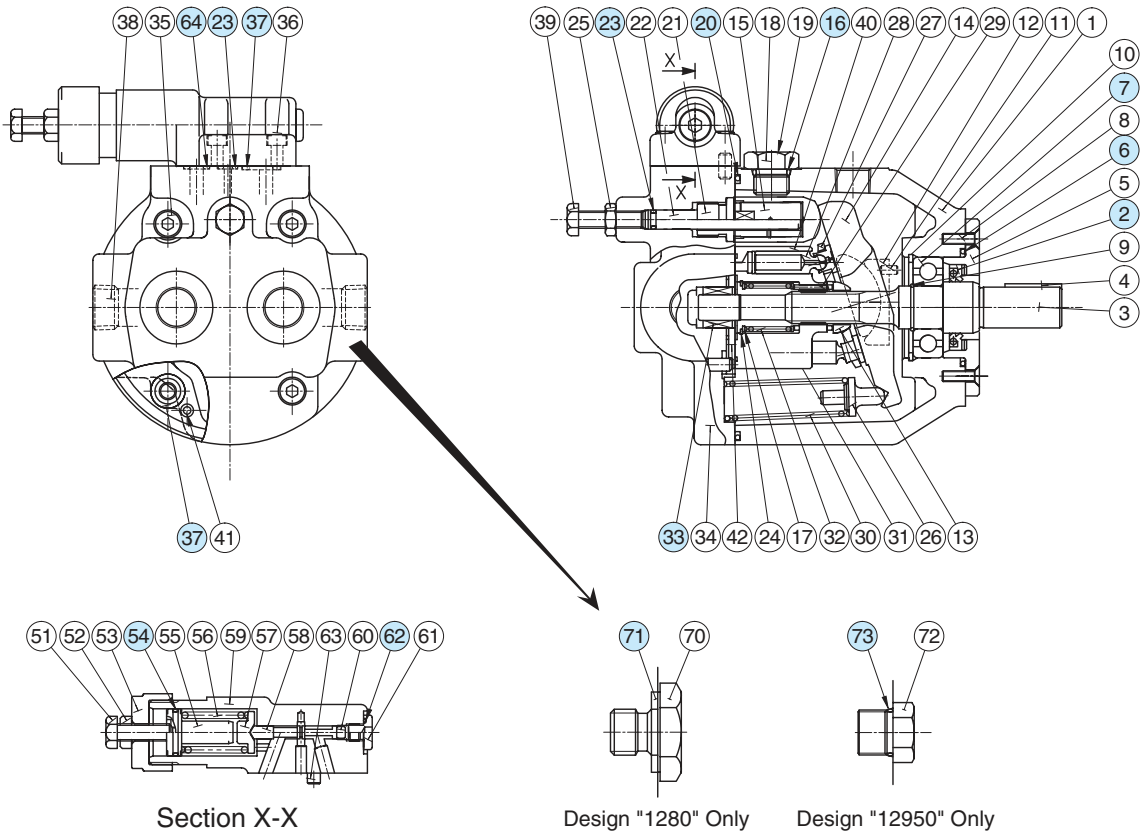

List of Seals & Bearings

Item	Name of Parts	Part Numbers	Qty.		Remarks
			Pres. Adj. Range		
			B	C & H	
2*	Oil Seal	TCN24408Y	1	1	
6*	O-Ring	SO-NA-G50	1	1	
7	Bearing	6204	1	1	
16*	O-Ring	SO-NB-P14	1	1	
20*	O-Ring	SO-NB-G120	1	1	
23*	O-Ring	SO-NB-P6	2	2	
33	Bearing	HMK1215	1	1	
37*	O-Ring	SO-NB-P12	6	5	
54*	O-Ring	SO-NA-A018	1	1	
62*	O-Ring	SO-NB-P10	1	1	
64*	O-Ring	SO-NB-P9	—	1	
71	Bonded Seal	KP-C-04	—	2	Only for "1280" Design, Not included in Seal Kit
73	O-Ring	AS568-908 (NBR, Hs90)	—	2	Only for "12950" Design, Not included in Seal Kit

★ When ordering seals, please specify the seal kit number from the table below.

List of Seal Kits

Pump Model Numbers	Seal Kit Numbers
A10-FR01B-12	KS-A10-01B-12
A10-FR01C-12/1280/12950	KS-A10-01H-12
A10-FR01H-12/1280/12950	

**Spare Parts List**

A16/A22/A37/A56-\*-R-01-\*-K-32/3280/32950

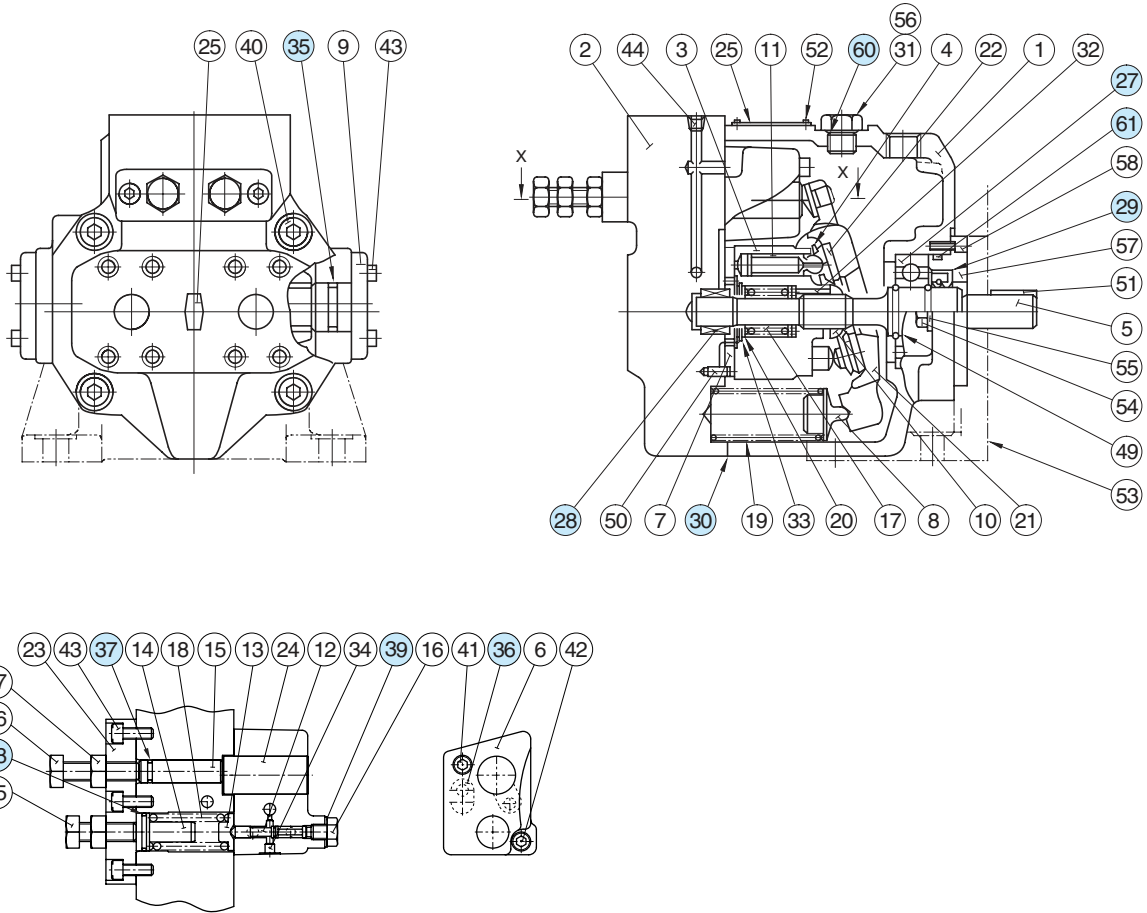

Section X-X

● List of Seals and Bearings

Item	Name of Parts	Part Numbers				Qty.
		A16-*-R-01	A22-*-R-01	A37-*-R-01	A56-*-R-01	
27	Bearing	6305		6307	NUP 207E	1
28	Bearing	HMK 1715	Z30-1303-PK410300-8	HMK 2025V2	HMK 2530V2	1
29*	Oil Seal	TCN 254511		TCN 355511	TCN 355511	1
30*	Gasket	1303-PK211969-1		1316-PK211970-9	1307-PK211971-7	1
35*	O-Ring	SO-NA-G25		SO-NA-G30	SO-NA-P36	2
36*	O-Ring	SO-NB-P12		SO-NB-P10A		1
37*	O-Ring	SO-NB-P9				1
38*	O-Ring	SO-NA-A017				1
39*	Seal Washer	W8				1
60*	O-Ring	SO-NB-P14				1
61*	O-Ring	SO-NA-G55		SO-NA-G75		1

★When ordering seals, please specify the seal kit number from the table below.

● List of Seal Kits

Pump Model Numbers	Seal Kit Numbers
A16-*-R-01-*-K-*-32*	KS-A16-01-32
A22-*-R-01-*-K-*-32*	
A37-*-R-01-*-K-*-32*	KS-A37-01-32
A56-*-R-01-*-K-*-32*	KS-A56-01-32



### Spare Parts List

A70/A90-\*R01\*S-60/6080/60950

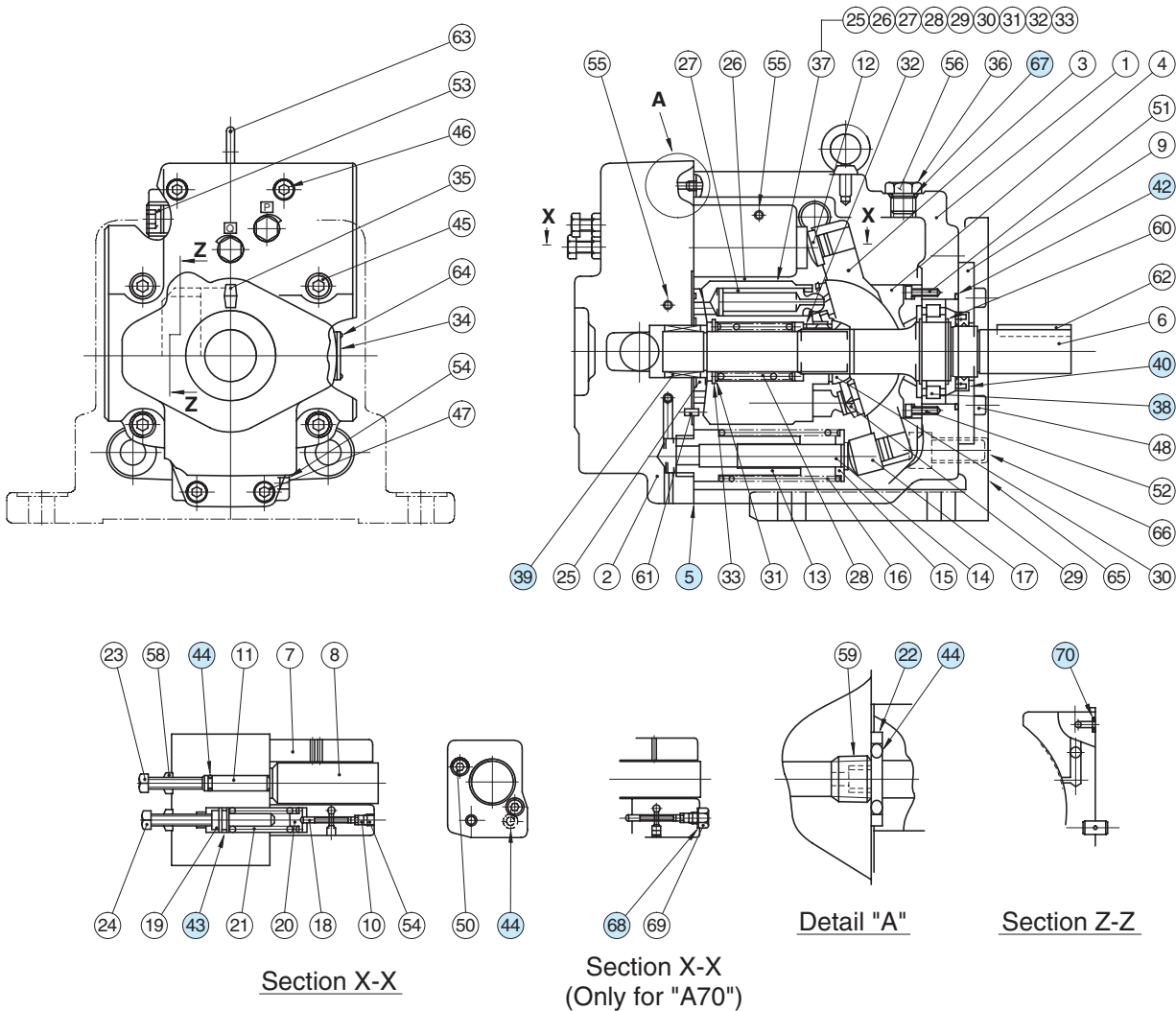

#### List of Seals and Bearings

Item	Name of Parts	Part Numbers		Qty.
		A70-*R01*S	A90-*R01*S	
5*	Gasket	1314E-PK211972-5	1310E-PK211973-3	1
22	Back Up Ring	1310E-PK412440-0	1310E-PK412440-0	1
38	Bearing	NUP 208EX50	NUP 210E	1
39	Needle Bearing	HMK 3030V2	HMK 3530BV2	1
40*	Oil Seal	TCN 355511	TCN 456812	1
42*	O-Ring	SO-FA-G85	SO-FA-G95	1
43*	O-Ring	SO-NA-P18	SO-NA-P18	1
44*	O-Ring	SO-NB-P9	SO-NB-P9	3
67*	O-Ring	SO-NB-P14	SO-NB-P18	1
68*	Seal Washer	W10	—	1
70*	O-Ring	SO-NB-P15	SO-NB-P5	1

#### List of Seal Kits

Pump Model Numbers	Seal Kit Numbers
A70-*R01*S-60*	KS-A70-01-60
A90-*R01*S-60*	KS-A90-01-60

★ When ordering the seals, please specify the seal kit number from the table left.

**Spare Parts List**

A145-\*R01\*S-60/6080/60950

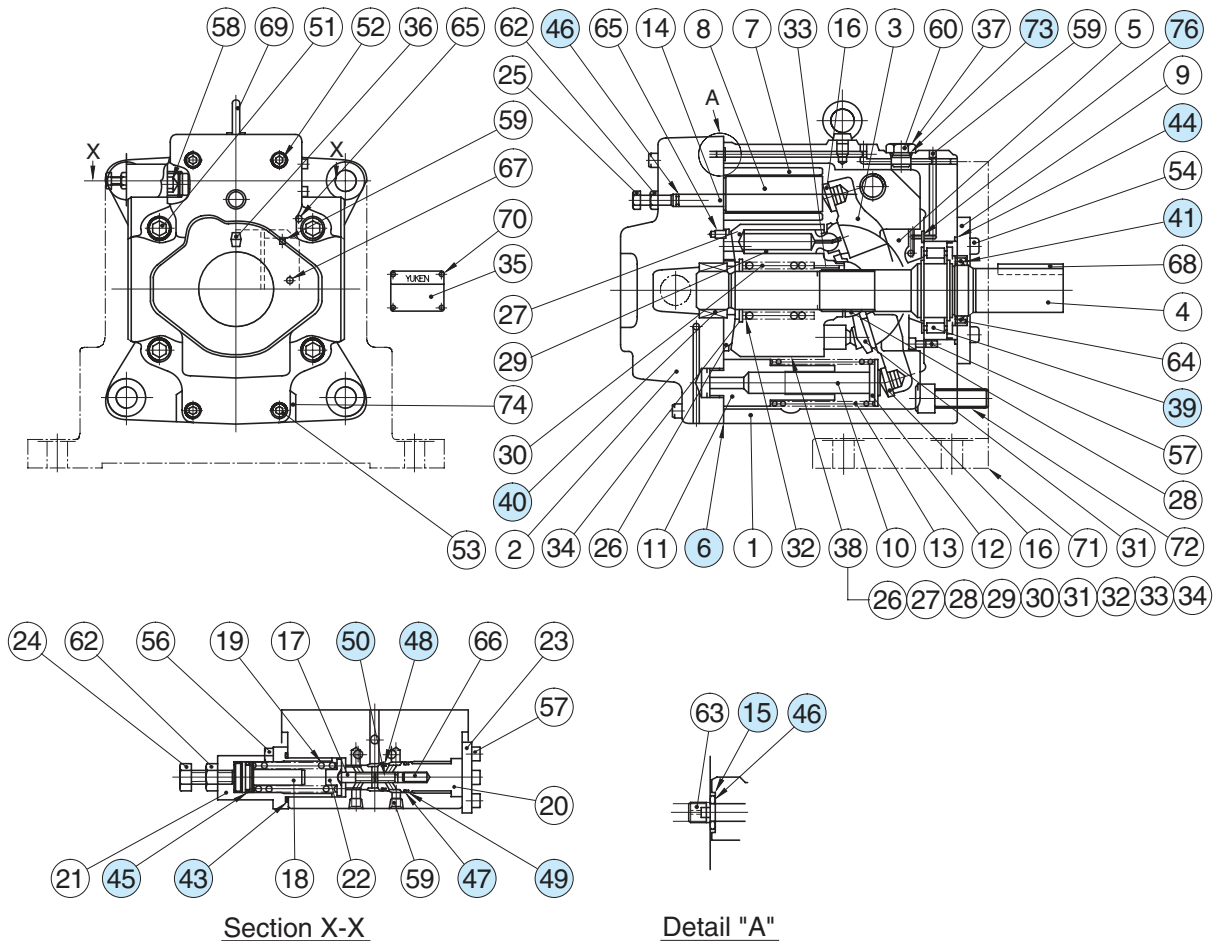

● List of Seals and Bearings

Item	Name of Parts	Part Numbers	Qty.
6*	Gasket	1312-PK211974-1	1
15	Back Up Ring	1310E-PK412440-0	1
39	Bearing	NUP 2211ET2	1
40	Needle Bearing	8Q-NK38×55×30	1
41*	Oil Seal	TCN 507212	1
43*	O-Ring	S-31.5 (NBR, Hs70)	1
44*	O-Ring	SO-FA-G105	1
45*	O-Ring	SO-NA-P18	1
46*	O-Ring	SO-NB-P9	2
47*	O-Ring	SO-NA-A017	1
48*	O-Ring	SO-NA-A016	1
49	Back Up Ring	For SO-NB-A017	1
50	Back Up Ring	For SO-NB-A016	1
73*	O-Ring	SO-NB-P18	1
76*	O-Ring	SO-NB-P5	1

★ When ordering seals, please specify the kit number "KS-A145-01-60".



## "A" Series Variable Displacement Piston Pumps – Single Pump, Solenoid Two Pressure Control Type

Graphic Symbol

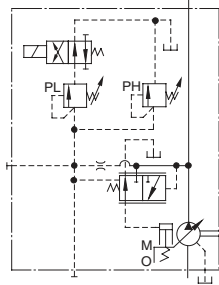

Performance Characteristics

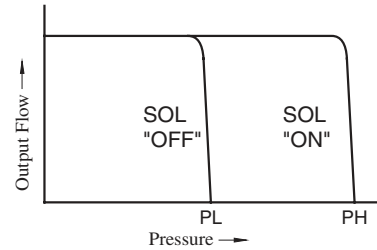

### Specifications

Model Numbers	Geometric Displacement cm <sup>3</sup> /rev (cu. in. /rev)	Minimum Adj. Flow cm <sup>3</sup> /rev (cu. in. /rev)	Operating Pressure MPa (PSI)		Minimum Adj. Pres. MPa (PSI)	Shaft Speed Range r/min		Approx. Mass kg (lbs.)	
			Rated <sup>★2</sup>	Intermittent <sup>★1</sup>		Max.	Min.	Flange Mtg.	Foot Mtg.
A16-*-R-02-*-K*-32*	15.8 (.964)	4 (.244)	16 (2320)	21 (3050)	1.2 (170)	1800	600	24.5 (54.0)	26.7 (58.9)
A22-*-R-02-*-K*-32*	22.2 (1.355)	6 (.366)	16 (2320)	16 (2320)	1.2 (170)	1800	600	24.5 (54.0)	26.7 (58.9)
A37-*-R-02-*-K*-32*	36.9 (2.25)	10 (.61)	16 (2320)	21 (3050)	1.2 (170)	1800	600	36 (79.4)	40.3 (88.9)
A56-*-R-02-*-K*-32*	56.2 (3.43)	12 (.73)	16 (2320)	21 (3050)	1.2 (170)	1800	600	43 (94.8)	47.3 (104)
A70-*-R02S*-60*	70.0 (4.27)	30 (1.83)	25 (3630)	25 (3630)	2 (290)	1800	600	63.5 (140)	75.5 (166)
A90-*-R02S*-60*	91.0 (5.55)	56 (3.42)	25 (3630)	25 (3630)	2 (290)	1800	600	80.5 (178)	101 (223)
A145-*-R02S*-60*	145 (8.85)	83 (5.06)	25 (3630)	25 (3630)	2 (290)	1800	600	97.5 (215)	122.5 (270)

★1. Whenever setting pressure, make sure the full cut-off pressure never exceeds the maximum intermittent pressure. ★2. When operating the pump exceeding the rated pressure, operating conditions are restricted. Refer to [page 33](#) for the details.

### Solenoid Ratings

Solenoid operated directional valves used on these pumps are YUKEN DSG-01 series (standard type). For detail specifications of solenoid operated directional valves, refer to [page 345](#).

## Model Number Designation

A16	-F	-R	-02	-S	-K	-A100	-32	*
Series Number	Mounting	Direction of Rotation	Control Type	Port Position	Shaft Extension	Coil Type of Solenoid Valve	Design Number	Design Std.
A16 (15.8 cm <sup>3</sup> /rev)	F: Flange Mtg.  L: Foot Mtg.	(Viewed from Shaft End)  R: Clockwise <sup>*1</sup> (Normal)	02: Solenoid Two Pressure Control Type	None: Axial Port  S: Side Port	K: Keyed Shaft	AC A100, A120 A200, A240  DC D12, D24 D48  R(AC→DC Rectified) R100, R200	32	Refer to <sup>*2</sup>
A22 (22.2 cm <sup>3</sup> /rev)							32	
A37 (36.9 cm <sup>3</sup> /rev)							32	
A56 (56.2 cm <sup>3</sup> /rev)							32	

A70	-F	R	02	S	A100	-60	*
Series Number	Mounting	Direction of Rotation	Control Type	Port Position	Coil Type of Solenoid Valve	Design Number	Design Std.
A70 (70.0 cm <sup>3</sup> /rev)	F: Flange Mtg.  L: Foot Mtg.	(Viewed from Shaft End)  R: Clockwise <sup>*1</sup> (Normal)	02: Solenoid Two Pressure Control Type	S: Side Port	AC A100, A120 A200, A240  DC D12, D24 D48  R(AC→DC Rectified) R100, R200	60	Refer to <sup>*2</sup>
A90 (91.0 cm <sup>3</sup> /rev)						60	
A145 (145 cm <sup>3</sup> /rev)						60	

★1. Available to supply pump with anti-clockwise rotation. Consult Yuken for details.

★2. Design Standards: None..... Japanese Standard "JIS"  
80 ..... European Design Standard  
950 ..... N. American Design Standard

## Performance Characteristics

For performance characteristics, refer to models of pressure compensator type on [page 37 to 43](#).

## Pipe Flange Kits

For pipe flange, refer to form of pressure compensator type on [page 34](#).

Axial Port Type

Flange Mtg.: A16-F-R-02-K-\*-32/32950  
A22-F-R-02-K-\*-32/32950

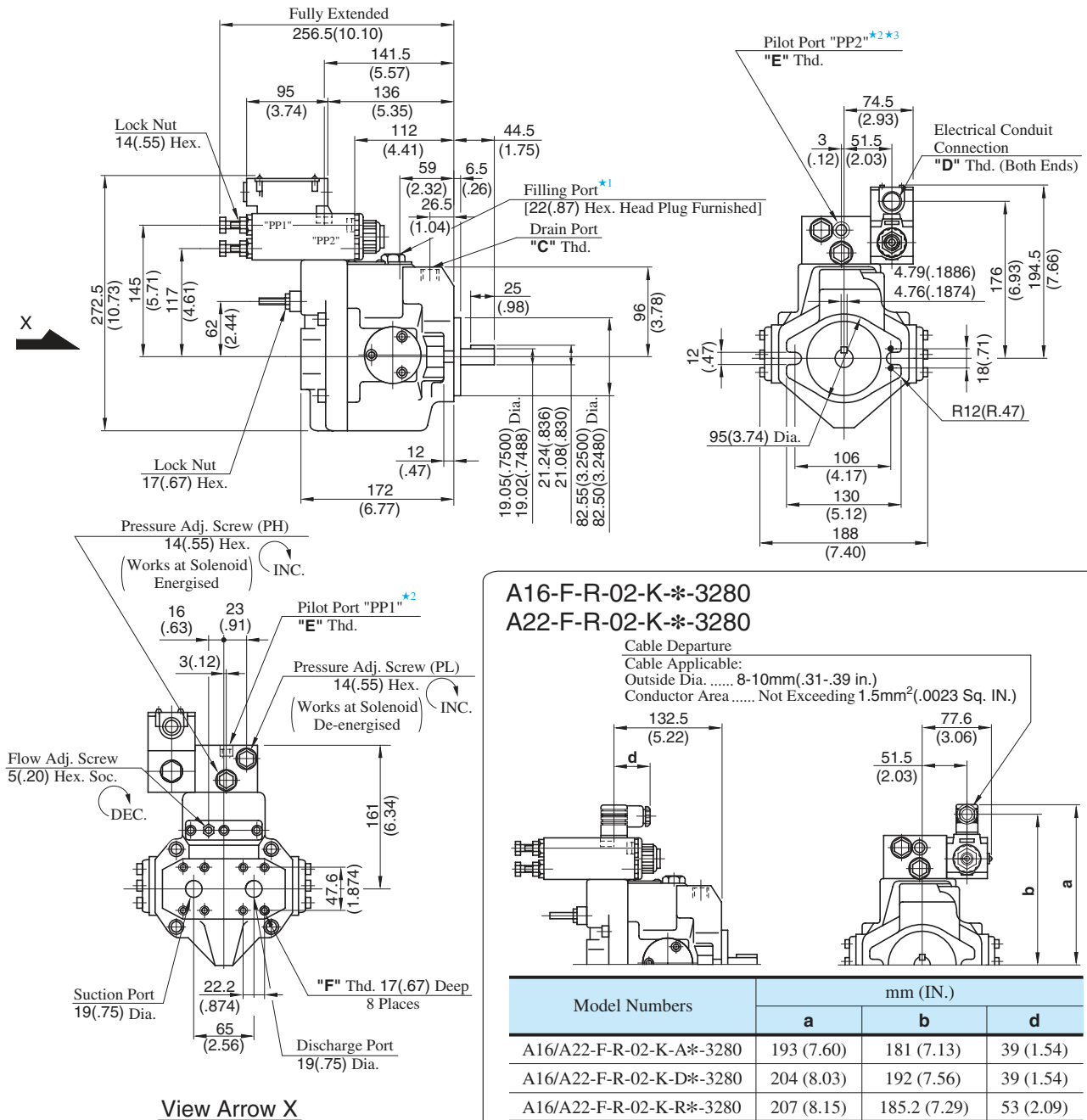

- ★ 1. Install the pump so that the "Filling Port" is at the top.
- ★ 2. The pilot port provided is for connecting a control valve, if multistage pressure control is required.
- ★ 3. The pilot port "PP2" is not provided for N.American Design Standard.

Model Numbers	"C" Thd.	"D" Thd.	"E" Thd.	"F" Thd.
A16/A22-F-R-02-K-*-32	Rc 3/8	G 1/2	Rc 1/4	M10
A16/A22-F-R-02-K-*-3280	3/8 BSP.F	—	1/4 BSP. Tr	
A16/A22-F-R-02-K-*-32950	SAE #8	1/2 NPT	SAE #4	

DIMENSIONS IN MILLIMETRES (INCHES)

• Side Port Type

Port mounting dimensions are the same as those of pressure compensator model.  
Refer to page 45 for port mounting dimensions.

• Foot Mounting Type

Mounting bracket is common to that of pressure compensator model.  
Refer to page 45 for the dimensions of mounting bracket.

**Side Port Type**

Flange Mtg. : A37-F-R-02-S-K-\*-32/32950

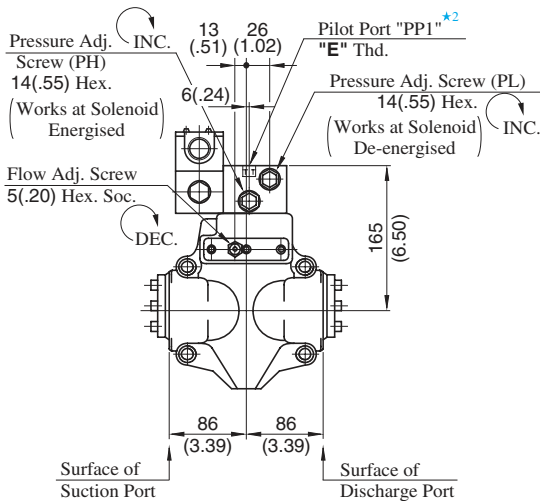
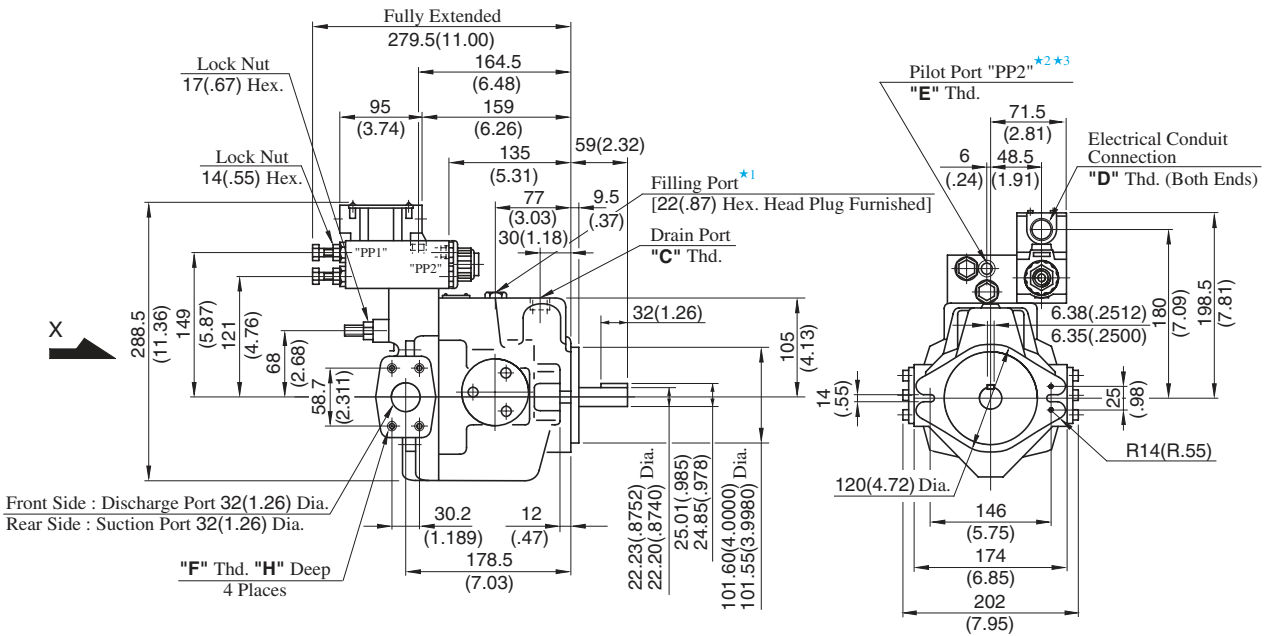

**View Arrow X**

- ★ 1. Install the pump so that the "Filling Port" is at the top.
- ★ 2. The pilot port provided is for connecting a control valve, if multistage pressure control is required.
- ★ 3. The pilot port "PP2" is not provided for N.American Design Standard.

**A37-F-R-02-S-K-\*-3280**

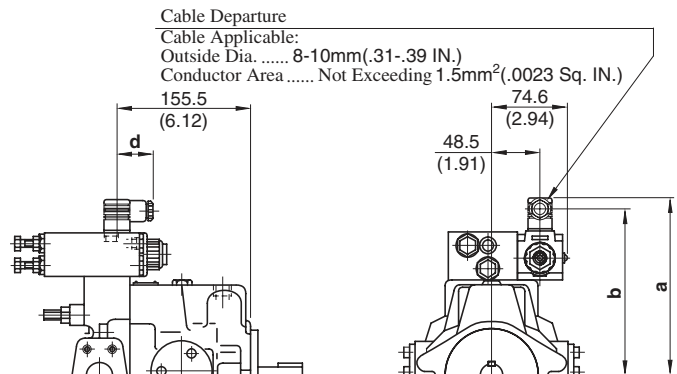

Model Numbers	mm (IN.)		
	a	b	d
A37-F-R-02-S-K-A*-3280	197 (7.76)	185 (7.28)	39 (1.54)
A37-F-R-02-S-K-D*-3280	208 (8.19)	196 (7.72)	39 (1.54)
A37-F-R-02-S-K-R*-3280	211 (8.31)	189.2 (7.45)	53 (2.09)

• For other dimensions, refer to 32/32950 design.

Model Numbers	"C" Thd.	"D" Thd.	"E" Thd.	"F" Thd.	"H" mm (IN.)
A37-F-R-02-S-K-*-32	Rc 1/2	G 1/2	Rc 1/4	M10	19 (.75)
A37-F-R-02-S-K-*-3280	1/2 BSP.F	—	1/4 BSP. Tr		
A37-F-R-02-S-K-*-32950	SAE #10	1/2 NPT	SAE #4	7/16-14 UNC	20 (.79)

**DIMENSIONS IN MILLIMETRES (INCHES)**

● **Axial Port Type**

Port mounting dimensions are the same as those of pressure compensator model.  
Refer to page 46 for port mounting dimensions.

● **Foot Mounting Type**

Mounting bracket is common to that of pressure compensator model.  
Refer to page 46 for the dimensions of mounting bracket.

Side Port Type

Flange Mtg.: A56-F-R-02-S-K\*-32/32950

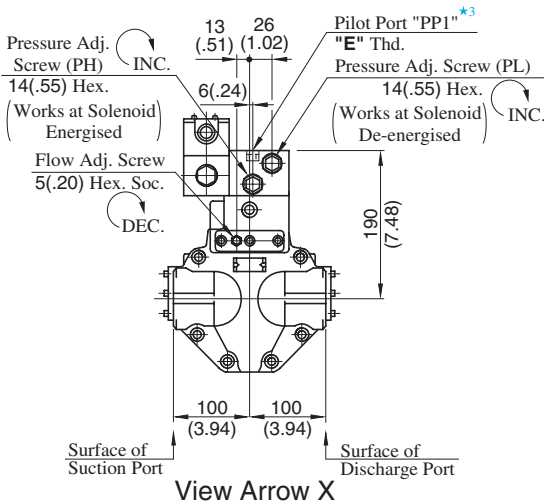
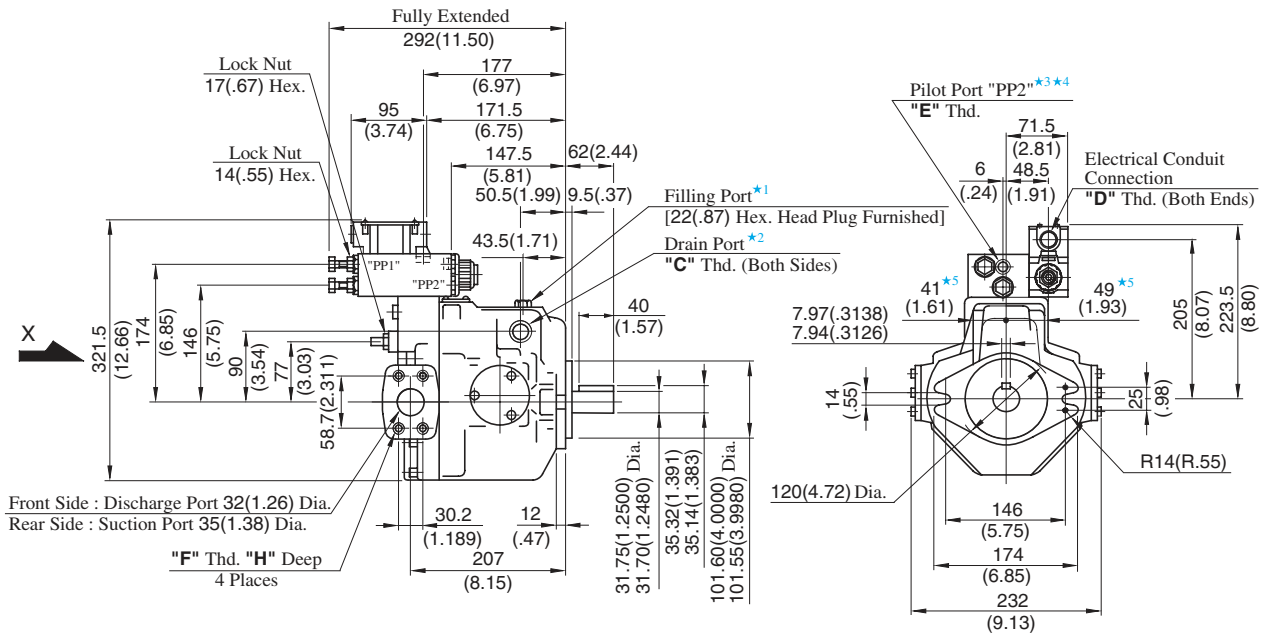

A56-F-R-02-S-K\*-3280

Cable Departure  
Cable Applicable:  
Outside Dia. .... 8-10mm(.31-.39 IN.)  
Conductor Area ..... Not Exceeding 1.5mm<sup>2</sup>(.0023 Sq. IN.)

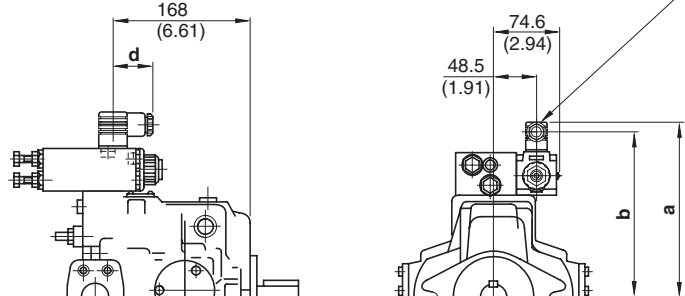

- ★ 1. Install the pump so that the "Filling Port" is at the top.
- ★ 2. Use either port of two drain ports at your option. Keep the remaining port plugged.
- ★ 3. The pilot port provided is for connecting a control valve, if multistage pressure control is required.
- ★ 4. The pilot port "PP2" is not provided for N.American Design Standard.
- ★ 5. Dimensions show surface of drain port.

Model Numbers	mm (IN.)		
	a	b	d
A56-F-R-02-S-K-A*-3280	222 (8.74)	210 (8.27)	39 (1.54)
A56-F-R-02-S-K-D*-3280	233 (9.17)	221 (8.70)	39 (1.54)
A56-F-R-02-S-K-R*-3280	236 (9.29)	214.2 (8.43)	53 (2.09)

• For other dimensions, refer to 32/32950 design.

Model Numbers	"C" Thd.	"D" Thd.	"E" Thd.	"F" Thd.	"H" mm (IN.)
A56-F-R-02-S-K*-32	Rc 3/4	G 1/2	Rc 1/4	M10	19 (.75)
A56-F-R-02-S-K*-3280	3/4 BSP.F	—	1/4 BSP. Tr		
A56-F-R-02-S-K*-32950	SAE #12	1/2 NPT	SAE #4	7/16-14 UNC	20 (.79)

DIMENSIONS IN MILLIMETRES (INCHES)

● Axial Port Type

Port mounting dimensions are the same as those of pressure compensator model.  
Refer to page 47 for port mounting dimensions.

● Foot Mounting Type

Mounting bracket is common to that of pressure compensator model.  
Refer to page 47 for the dimensions of mounting bracket.

Flange Mtg. : A70-FR02S\*-60/60950

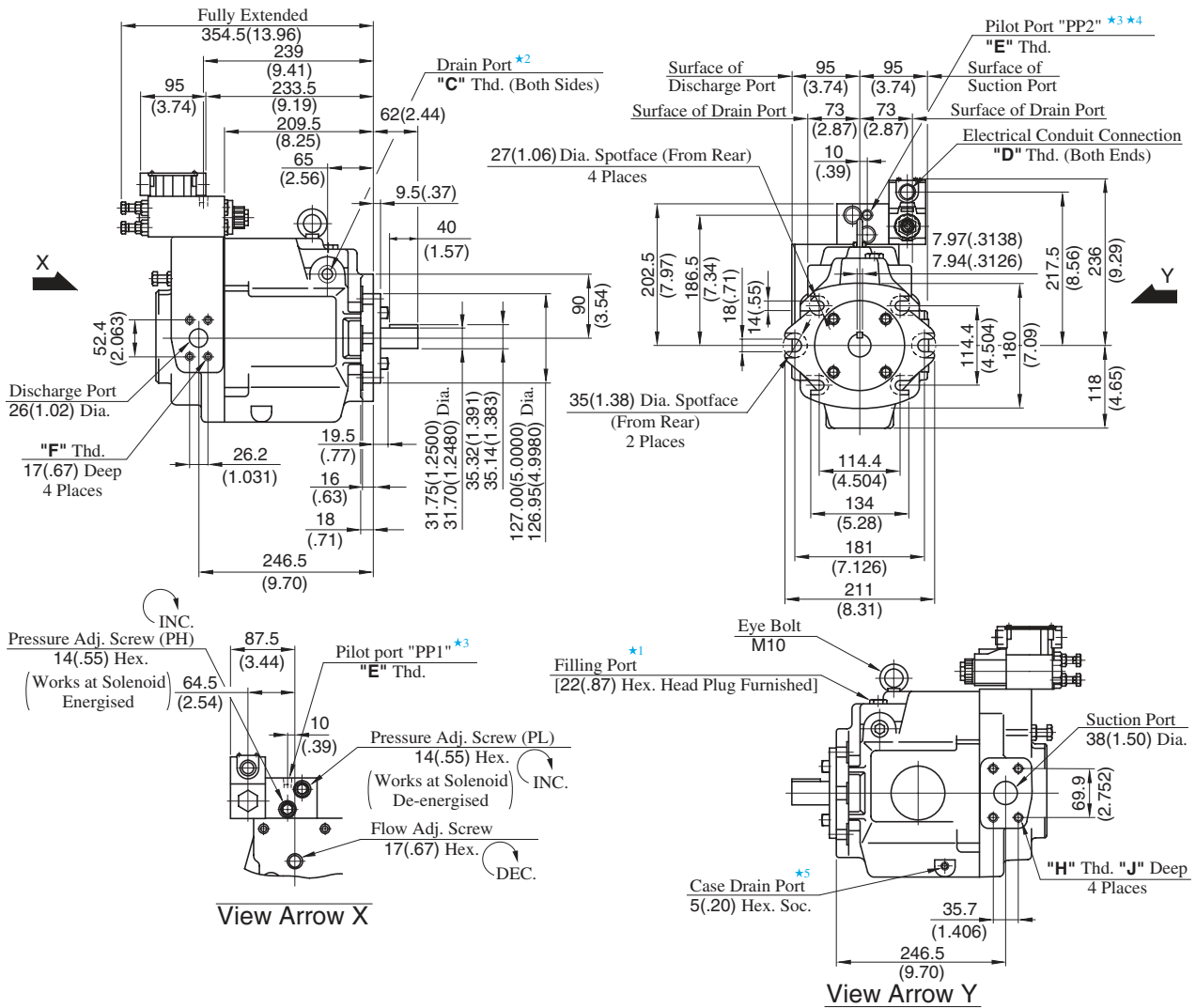

Model Numbers	"C" Thd.	"D" Thd.	"E" Thd.	"F" Thd.	"H" Thd.	"J" mm (IN.)
A70-FR02S*-60	Rc 3/4	G 1/2	Rc 1/4	M10	M12	19 (.75)
A70-FR02S*-6080	3/4 BSP.F	—	1/4 BSP. Tr			
A70-FR02S*-60950	SAE #12	1/2 NPT	SAE #4	7/16-14 UNC	1/2-13 UNC	21 (.83)

**A70-FR02S\*-6080**

Cable Departure  
Cable Applicable:  
Outside Dia. .... 8-10mm (.31-.39 IN.)  
Conductor Area ..... Not Exceeding 1.5mm<sup>2</sup> (.0023 Sq. IN.)

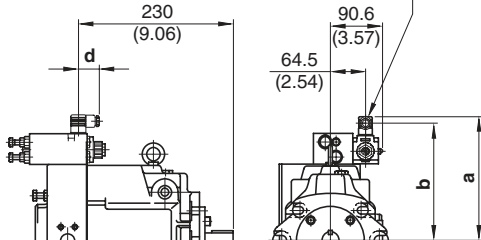

Model Numbers	mm (IN.)		
	a	b	d
A70-FR02SA*-6080	235 (9.25)	223 (8.78)	39 (1.54)
A70-FR02SD*-6080	246 (9.69)	234 (9.21)	39 (1.54)
A70-FR02SR*-6080	249 (9.80)	227.2 (8.94)	53 (2.09)

• For other dimensions, refer to 60/60950 design.

- ★ 1. Install the pump so that the "Filling Port" is at the top.
- ★ 2. Use either port of two drain ports at your option. Keep the remaining port plugged.
- ★ 3. The pilot port provided is for connecting a control valve, if multistage pressure control is required.
- ★ 4. The pilot port "PP2" is not provided for N.American Design Standard.
- ★ 5. Case drain port is available for use when draining hydraulic fluid from pump casing.

**DIMENSIONS IN MILLIMETRES (INCHES)**

• **Foot Mounting Type**

Mounting bracket is common to that of pressure compensator model. Refer to page 48 for the dimensions of mounting bracket.



Flange Mtg.: A90-FR02S\*-60/60950

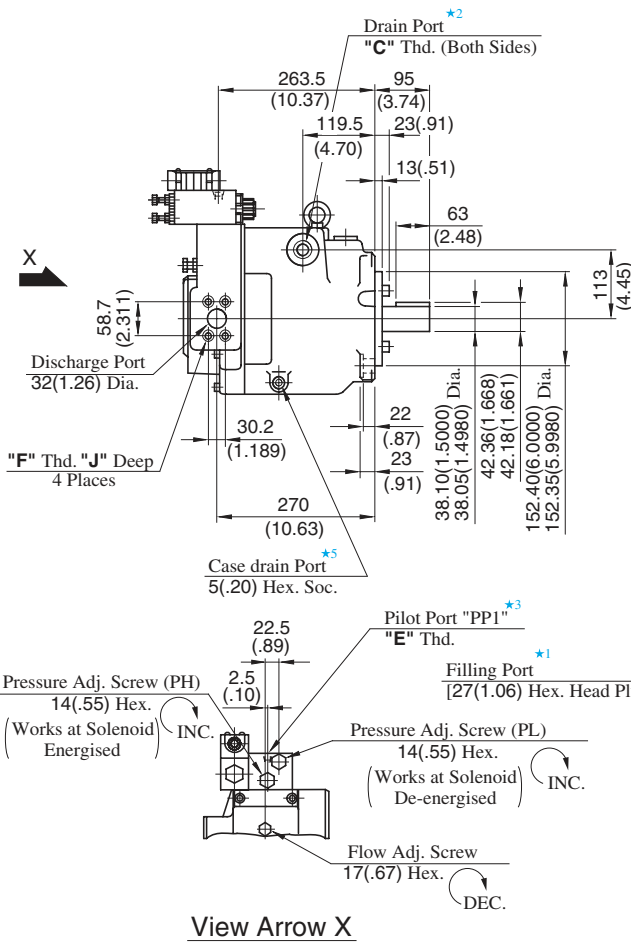

View Arrow X

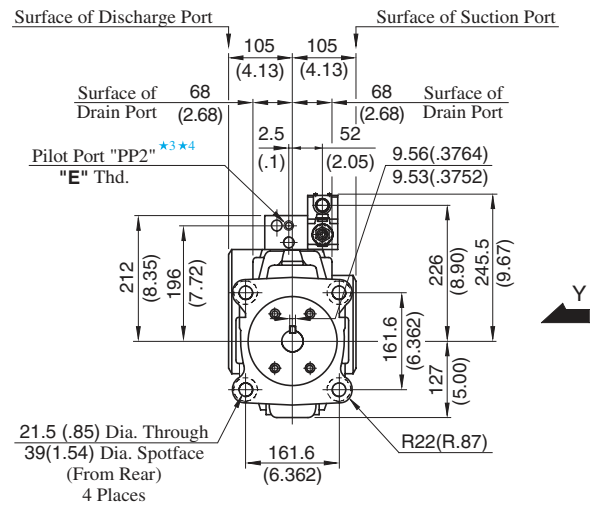

View Arrow Y

Model Numbers	"C" Thd.	"D" Thd.	"E" Thd.	"F" Thd.	"H" Thd.	"J" mm (IN.)	"K" mm (IN.)
A90-FR02S*-60	Rc 3/4	G 1/2	Rc 1/4	M10	M12	19 (.75)	19 (.75)
A90-FR02S*-6080	3/4 BSP.F	—	1/4 BSP. Tr				
A90-FR02S*-60950	SAE #12	1/2 NPT	SAE #4	7/16-14 UNC	1/2-13 UNC	20 (.79)	21 (.83)

A90-FR02S\*-6080

Cable Departure  
Cable Applicable:  
Outside Dia. 8-10mm(.31-.39 IN.)  
Conductor Area Not Exceeding 1.5mm<sup>2</sup>(.0023 Sq. IN.)

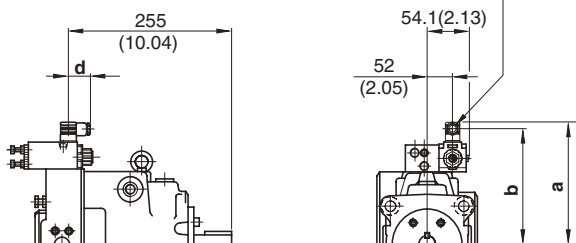

Model Numbers	mm (IN.)		
	a	b	d
A90-02FRSA*-6080	244 (9.61)	232 (9.13)	39 (1.54)
A90-02FRSD*-6080	255 (10.04)	243 (9.57)	39 (1.54)
A90-02FRSR*-6080	258 (10.16)	236.2 (9.30)	53 (2.09)

• For other dimensions, refer to 60/60950 design.

- ★ 1. Install the pump so that the "Filling Port" is at the top.
- ★ 2. Use either port of two drain ports at your option. Keep the remaining port plugged.
- ★ 3. The pilot port provided is for connecting a control valve, if multistage pressure control is required.
- ★ 4. The pilot port "PP2" is not provided for N.American Design Standard.
- ★ 5. Case drain port is available for use when draining hydraulic fluid from pump casing.

DIMENSIONS IN MILLIMETRES (INCHES)

• Foot Mounting Type

Mounting bracket is common to that of pressure compensator model. Refer to page 49 for the dimensions of mounting bracket.

Flange Mtg. : A145-FR02S\*-60/60950

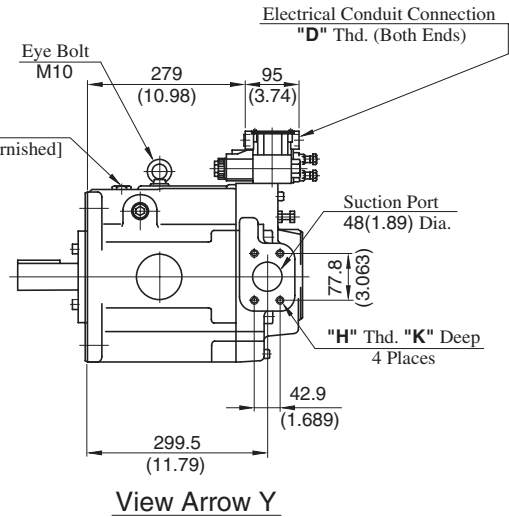
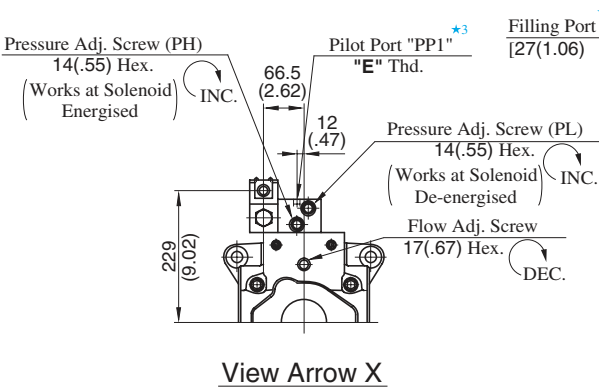
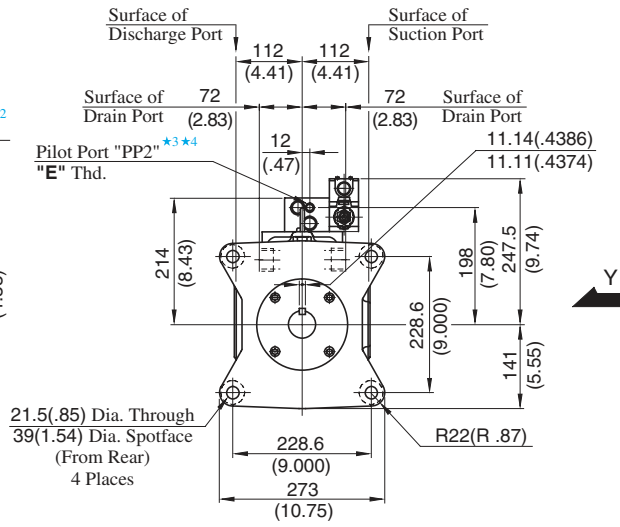
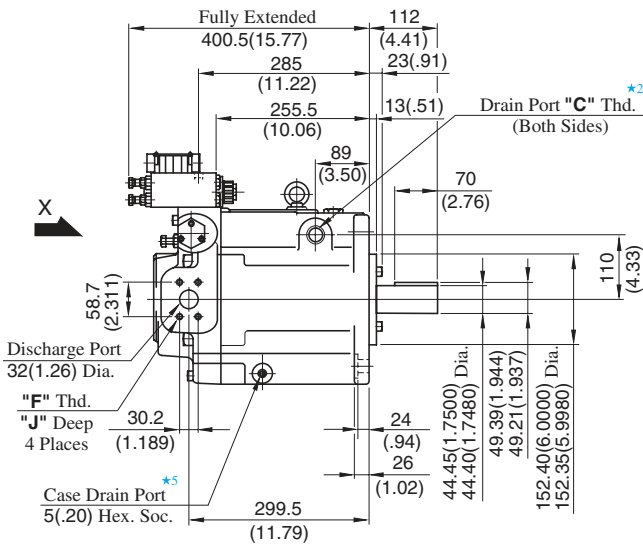

Model Numbers	"C" Thd.	"D" Thd.	"E" Thd.	"F" Thd.	"H" Thd.	"J" mm (IN.)	"K" mm (IN.)
A145-FR02S*-60	Rc 3/4	G 1/2	Rc 1/4	M10	M12	19 (.75)	19 (.75)
A145-FR02S*-6080	3/4 BSP.F	—	1/4 BSP. Tr				
A145-FR02S*-60950	SAE #12	1/2 NPT	SAE #4	7/16-14 UNC	1/2-13 UNC	20 (.79)	21 (.83)

A145-FR02S\*-6080

Cable Departure  
 Cable Applicable:  
 Outside Dia. 8-10mm(.31-.39 IN.)  
 Conductor Area Not Exceeding 1.5mm<sup>2</sup>(.0023 Sq. IN.)

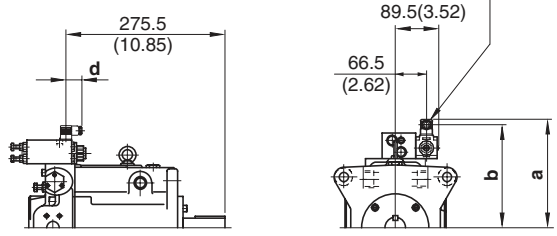

Model Numbers	mm (IN.)		
	a	b	d
A145-FR02SA*-6080	246 (9.69)	234 (9.21)	39 (1.54)
A145-FR02SD*-6080	257 (10.12)	245 (9.65)	39 (1.54)
A145-FR02SR*-6080	260 (10.24)	238.2 (9.38)	53 (2.09)

• For other dimensions, refer to 60/60950 design.

- ★ 1. Install the pump so that the "Filling Port" is at the top.
- ★ 2. Use either port of two drain ports at your option. Keep the remaining port plugged.
- ★ 3. The pilot port provided is for connecting a control valve, if multistage pressure control is required.
- ★ 4. The pilot port "PP2" is not provided for N.American Design Standard.
- ★ 5. Case drain port is available for use when draining hydraulic fluid from pump casing.

**DIMENSIONS IN MILLIMETRES (INCHES)**

• **Foot Mounting Type**

Mounting bracket is common to that of pressure compensator model. Refer to page 50 for the dimensions of mounting bracket.



# "A" Series Variable Displacement Piston Pumps – Single Pump, Pressure Compensator with Unloading Type

Graphic Symbol

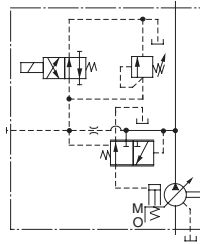

Performance Characteristics

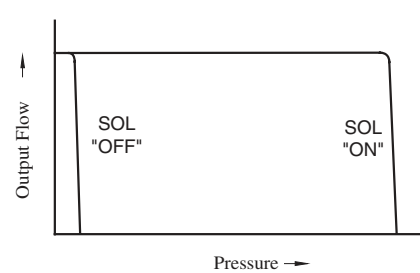

## Specifications

Model Numbers	Geometric Displacement cm <sup>3</sup> /rev (cu. in. /rev)	Minimum Adj. Flow cm <sup>3</sup> /rev (cu. in. /rev)	Operating Pressure MPa (PSI)		Unloading Pressure MPa (PSI)	Shaft Speed Range r/min	
			Rated	Intermittent		Max.	Min.
A16-*-R-03-*-K-*-32*	15.8 (.964)	4 (.244)	16 (2320)	21 (3050)	1.2 (170)	1800	600
A22-*-R-03-*-K-*-32*	22.2 (1.355)	6 (.366)	16 (2320)	16 (2320)	1.2 (170)	1800	600
A37-*-R-03-*-K-*-32*	36.9 (2.25)	10 (.61)	16 (2320)	21 (3050)	1.2 (170)	1800	600
A56-*-R-03-*-K-*-32*	56.2 (3.43)	12 (.73)	16 (2320)	21 (3050)	1.2 (170)	1800	600
A70-*R03S*-60*	70.0 (4.27)	30 (1.83)	25 (3630)	25 (3630)	1.2 (170)	1800	600
A90-*R03S*-60*	91.0 (5.55)	56 (3.42)	25 (3630)	25 (3630)	1.2 (170)	1800	600
A145-*R03S*-60*	145 (8.85)	83 (5.06)	25 (3630)	25 (3630)	1.2 (170)	1800	600

## Model Number Designation

A16	-F	-R	-03	-S	-K	-A100	-32	*
Series Number	Mounting	Direction of Rotation	Control Type	Port Position	Shaft Extension	Coil Type of Solenoid Valve	Design Number	Design Std.
<b>A16</b> (15.8 cm <sup>3</sup> /rev)	<b>F:</b> Flange Mtg.	(Viewed from Shaft End)	<b>03:</b> Pressure Compensator with Unloading Type	<b>None:</b> Axial Port	<b>K:</b> Keyed Shaft	AC <b>A100,A120</b> <b>A200,A240</b> DC <b>D12,D24</b> <b>D48</b> R(AC→DC Rectified) <b>R100,R200</b>	<b>32</b>	Refer to *2
<b>A22</b> (22.2 cm <sup>3</sup> /rev)							<b>32</b>	
<b>A37</b> (36.9 cm <sup>3</sup> /rev)							<b>32</b>	
<b>A56</b> (56.2 cm <sup>3</sup> /rev)							<b>32</b>	

A70	-F	R	03	S	A100	-60	*
Series Number	Mounting	Direction of Rotation	Control Type	Port Position	Coil Type of Solenoid Valve	Design Number	Design Std.
<b>A70</b> (70.0 cm <sup>3</sup> /rev)	<b>F:</b> Flange Mtg.	(Viewed from Shaft End)	<b>03:</b> Pressure Compensator with Unloading Type	<b>S:</b> Side Port	AC <b>A100,A120</b> <b>A200,A240</b> DC <b>D12,D24</b> <b>D48</b> R(AC→DC Rectified) <b>R100,R200</b>	<b>60</b>	Refer to *2
<b>A90</b> (91.0 cm <sup>3</sup> /rev)						<b>60</b>	
<b>A145</b> (145 cm <sup>3</sup> /rev)						<b>60</b>	

\*1. Available to supply pump with anti-clockwise rotation. Consult Yuken for details.

\*2. Design Standards: None ..... Japanese Standard "JIS"  
80 ..... European Design Standard  
950 ..... N. American Design Standard

Consult Yuken when detailed material such as dimensions figures is required.

# "A" Series Variable Displacement Piston Pumps – Single Pump, Proportional Electro-Hydraulic Load Sensing Type

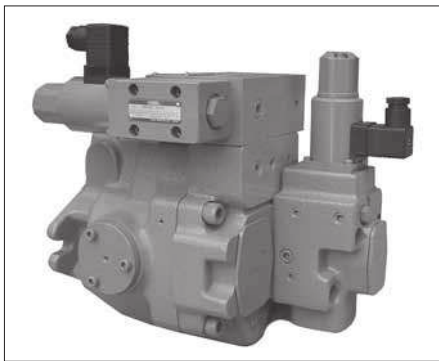

Performance Characteristics

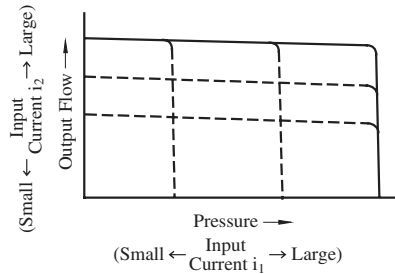

Graphic Symbols

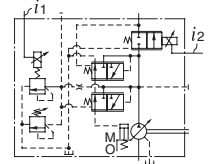

A16/A22/A37/A56

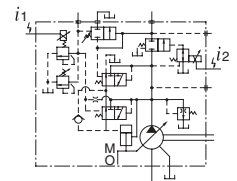

A70/A90/A145

## Model Number Designation

A56	-F	-R	-04	-C	-K	-32	*
Series Number	Mounting	Direction of Rotation	Control Type	Pressure Adj. Range MPa (PSI)	Shaft Extension	Design Number	Design Std.
<b>A16</b> (15.8 cm <sup>3</sup> /rev)	<b>F:</b> Flange Mtg.	(Viewed from Shaft End)  <b>R:</b> Clockwise *1	<b>04:</b> Proportional Electro-Hydraulic Load Sensing Type	<b>B:</b> 1.5 - 6.9 (220 - 1000) <b>C:</b> 1.5 - 15.7 (220 - 2280) <b>H:</b> 1.5 - 20.6 (220 - 2990)	<b>K:</b> Keyed Shaft	<b>32</b>	Refer to ★2
<b>A22</b> (22.2 cm <sup>3</sup> /rev)				<b>B:</b> 1.5 - 6.9 (220 - 1000) <b>C:</b> 1.5 - 15.7 (220 - 2280)		<b>32</b>	
<b>A37</b> (36.9 cm <sup>3</sup> /rev)				<b>B:</b> 2 - 6.9 (290 - 1000) <b>C:</b> 2 - 15.7 (290 - 2280) <b>H:</b> 2 - 20.6 (290 - 2990)		<b>32</b>	
<b>A56</b> (56.2 cm <sup>3</sup> /rev)				<b>B:</b> 2 - 6.9 (290 - 1000) <b>C:</b> 2 - 15.7 (290 - 2280) <b>H:</b> 2 - 20.6 (290 - 2990)		<b>32</b>	

A70	-F	R	04	C	S	-60	*
Series Number	Mounting	Direction of Rotation	Control Type	Pressure Adj. Range MPa (PSI)	Port Position	Design Number	Design Std.
<b>A70</b> (70.0 cm <sup>3</sup> /rev)	<b>F:</b> Flange Mtg.	(Viewed from Shaft End)  <b>R:</b> Clockwise *1	<b>04:</b> Proportional Electro-Hydraulic Load Sensing Type	<b>C:</b> 1.5 - 16 (220 - 2320) <b>H:</b> 1.5 - 21 (220 - 3050)	<b>S:</b> Side Port	<b>60</b>	Refer to ★2
<b>A90</b> (91.0 cm <sup>3</sup> /rev)						<b>60</b>	
<b>A145</b> (145 cm <sup>3</sup> /rev)						<b>60</b>	

★1. Available to supply pump with anti-clockwise rotation. Consult Yuken for details.

★2. Design Standards: None ..... Japanese Standard "JIS"  
80 ..... European Design Standard

• Consult Yuken when "N. American Design Standard" is required.



**Pipe Flange Kits**

Pipe flange kits are available.  
When ordering, specify the kit number from the table below.

Pump Model Numbers	Name of Port	Pipe Flange Kit Numbers			
		Threaded Connection		Socket Welding <sup>*1</sup>	Butt Welding
		Japanese Standard "JIS"	European Design Standard	Japanese Standard "JIS" & European Design Standard	Japanese Standard "JIS" & European Design Standard
A16-*R-04 A22-*R-04	Suction	F5-06-A-10	F5-06-A-1080	F5-06-B-10	F5-06-C-10
	Discharge	—*2	—*2	—*2	—*2
A37-*R-04 A56-*R-04	Suction	F5-10-A-10	F5-10-A-1080	F5-10-B-10	F5-10-C-10
	Discharge	F5-06-A-10	F5-06-A-1080	F5-06-B-10	F5-06-C-10
A70-*R04	Suction	F5-12-A-10	F5-12-A-1080	F5-12-B-10	F5-12-C-10
	Discharge	F5-10-A-10	F5-10-A-1080	F5-10-B-10	F5-10-C-10
A90-*R04 A145-*R04	Suction	F5-16-A-10	F5-16-A-1080	F5-16-B-10	F5-16-C-10
	Discharge	F5-10-A-10	F5-10-A-1080	F5-10-B-10	F5-10-C-10

★1. In case of using socket welding flanges, there is a case where the operating pressure should be set lower than the normal because of strength of the flanges. Therefore, please pay cautious attention to the operating pressure when the socket welding flanges are used.

★2. Discharge port for pump model "A16" and "A22" is available only the threaded connections.

- Detail of the pipe flange kits are shown on page 824.

**Instructions**

**Bleeding Air**

In order to get steadily controlled pressure and flow, bleed air by loosening the air vent screw and fill solenoid armature with operating oil.

**Manual Adjustment Screws**

Manual adjustment screws may be used for initial running adjustment or in case of electrical failures in order to adjust pressure and flow temporarily. In case of normal use, put the manual adjustment screws back in their preset positions.

**Position of Cable Departure**

Position of cable departure can be changed. For details, refer to EDG-01 valve on page 672.

**Connection of Surge Cut-off Valve to "A" Series Pump (For A16 to A56 Type)**

If using surge cut-off valve (SF1105-A-10), connect between pilot port "PP" of this pump and port "PP" of surge cut-off valve as pilot piping (refer to drawing below).

Inside diameter of pipe should be more than 8 mm(.32 in.).

Consult Yuken of detail of surge cut-off valve.

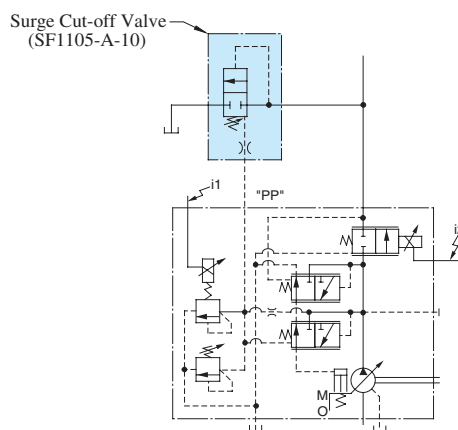

## Specifications

Descriptions		Model No.	A16	A22	A37	A56	A70	A90	A145	
Geometric Displacement		cm <sup>3</sup> /rev (cu. in./rev)	15.8 (.964)	22.2 (1.355)	36.9 (2.25)	56.2 (3.43)	70.0 (4.27)	91.0 (5.55)	145 (8.85)	
Operating Pressure MPa (PSI)		Rated <sup>*2</sup>	16 (2320)	16 (2320)	16 (2320)	16 (2320)	21 (3050)	21 (3050)	21 (3050)	
		Intermittent <sup>*1</sup>	21 (3050)	16 (2320)	21 (3050)	21 (3050)	21 (3050)	21 (3050)	21 (3050)	
Shaft Speed Range r/min		Max.	1800	1800	1800	1800	1800	1800	1800	
		Min.	600	600	600	600	600	600	600	
Flow Control		Flow Adj. Range L/min (U.S. GPM)	1 - 28.4 (.26 - 7.5)	1 - 40 (.26 - 10.6)	1 - 66 (.26 - 17.4)	1 - 101 (.26 - 26.7)	1 - 126 (.26 - 33.3)	1 - 163 (.26 - 43.1)	2 - 261 (.53 - 69.0)	
		Min Pres. Required for Flow Adj. MPa (PSI)	1.5 (220)	1.5 (220)	1.5 (220)	2.0 (290)	1.0 (145)	1.0 (145)	1.0 (145)	
		Differential Pres. (Discharge Pres. - Load Pres.) MPa (PSI)	0.37 (55)			0.22 (30)				
		Step Response <sup>*5</sup> (0 → Max. Flow) ms	70	80	120	125	100	120	210	
		Hysteresis	3% or less <sup>*4</sup>							
		Rated Current mA	900	700	740	790	820	920	920	
		Coil Resistance [20°C (68°F)]	10							
Pres. Control		Pres. Adj. Range MPa (PSI)	Refer to Model Number Designation							
		Step Response ms	t <sub>1</sub> <sup>*5</sup>	80	80	50	55	150	150	160
			t <sub>2</sub> <sup>*5</sup>	140	90	80	80	80	120	180
		Hysteresis	2% or less <sup>*4</sup>							
		Rated Current mA	(Pres. Adj. Range) B: 770, C: 880, H: 790					C: 860 H: 765	C: 873 H: 765	C: 875 H: 755
Coil Resistance [20°C (68°F)]	Ω	10								
Applicable Amplifier Model <sup>*3</sup>		AME-D2-1010-*-10								
Approx. Mass kg (lbs.)		Flange Mtg.	32 (70.6)	32 (70.6)	38 (83.8)	45 (99.2)	72.5 (160)	88.5 (195)	109.5 (241)	
		Foot Mtg.	34.2 (75.4)	34.2 (75.4)	43.2 (95.3)	49.3 (109)	84.5 (186)	109 (240)	134.5 (297)	

- ★ 1. Whenever setting pressure, make sure the full cut-off pressure never exceeds the maximum intermittent pressure.
- ★ 2. When operating the pump exceeding the rated pressure, operating conditions are restricted. Refer to page 33 for the details.
- ★ 3. For detail specifications of power amplifiers, refer to page 780.
- ★ 4. The figure mentioned in the above table are those obtained using Yuken's amplifier.
- ★ 5. Step response depends on circuit and operating conditions. Data shown in the table above is an example based on the condition right.

Model	Pres. Step Response		Loading Volume
	t <sub>1</sub>	t <sub>2</sub>	
A16, A22	1.5 → 16 MPa (220 → 2320 PSI)	16 → 1.5 MPa (2320 → 220 PSI)	High Pressure Hose 3/8" × 2 m (6.6 ft)
A37, A56	2.0 → 16 MPa (290 → 2320 PSI)	16 → 2.0 MPa (2320 → 290 PSI)	High Pressure Hose 3/4" × 2 m (6.6 ft)
A70, A90 A145	3.0 → 16 MPa (435 → 2320 PSI)	16 → 3.0 MPa (2320 → 435 PSI)	High Pressure Hose 1-1/4" × 2 m (6.6 ft)



Typical Performance Characteristics at Viscosity 20 mm<sup>2</sup>/s (100 SSU) [ISO VG32 Oils, 50°C (122°F)]

### Full Cut-off Pres. vs. Input Current

#### ● A16/A22/A37/A56

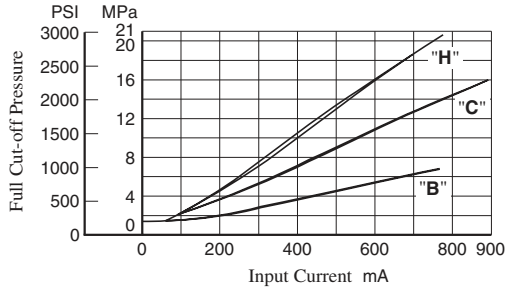

#### ● A70/A90/A145

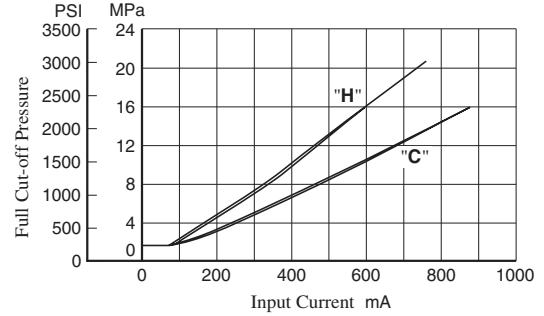

Note: Pressure adjustment range "H" is not available for A22.

### Output Flow vs. Input Current

#### ● A16

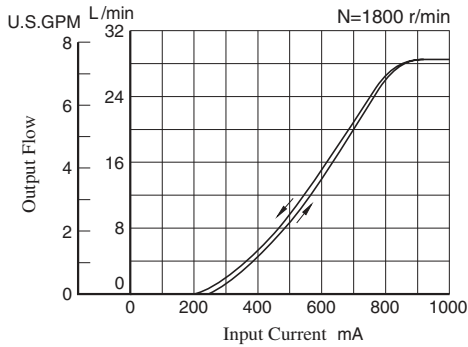

#### ● A22

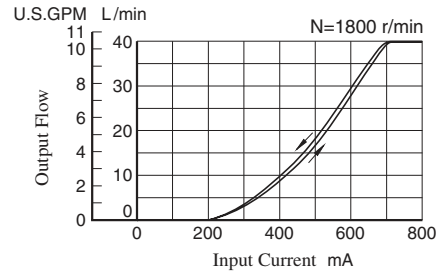

#### ● A37

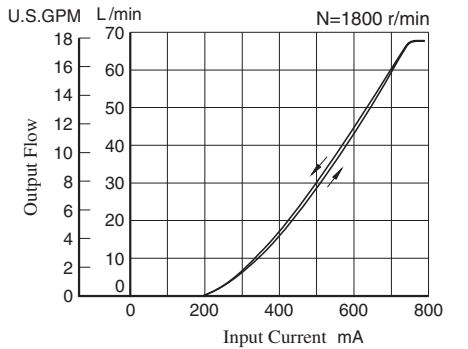

#### ● A56

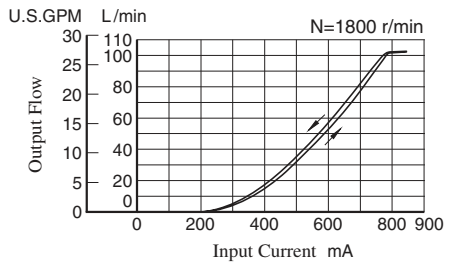

#### ● A70

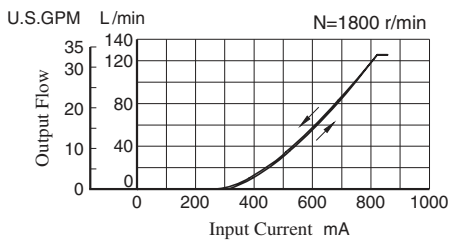

#### ● A90

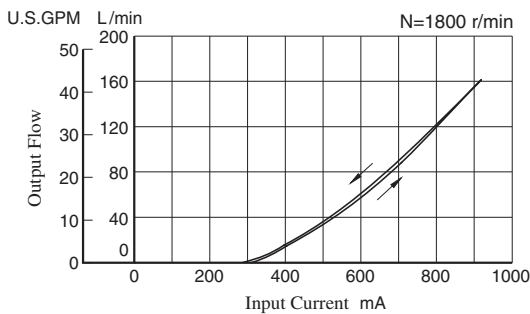

#### ● A145

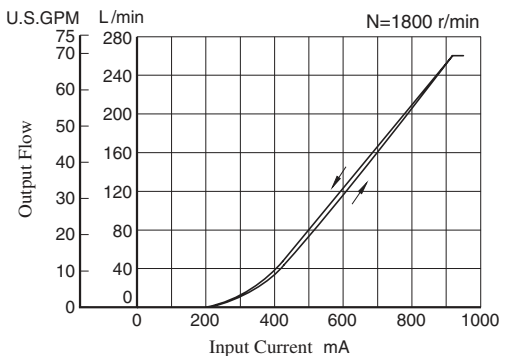

Flange Mtg. : A16-F-R-04-\*K-32/3280  
 A22-F-R-04-\*K-32/3280

**DIMENSIONS IN  
 MILLIMETRES (INCHES)**

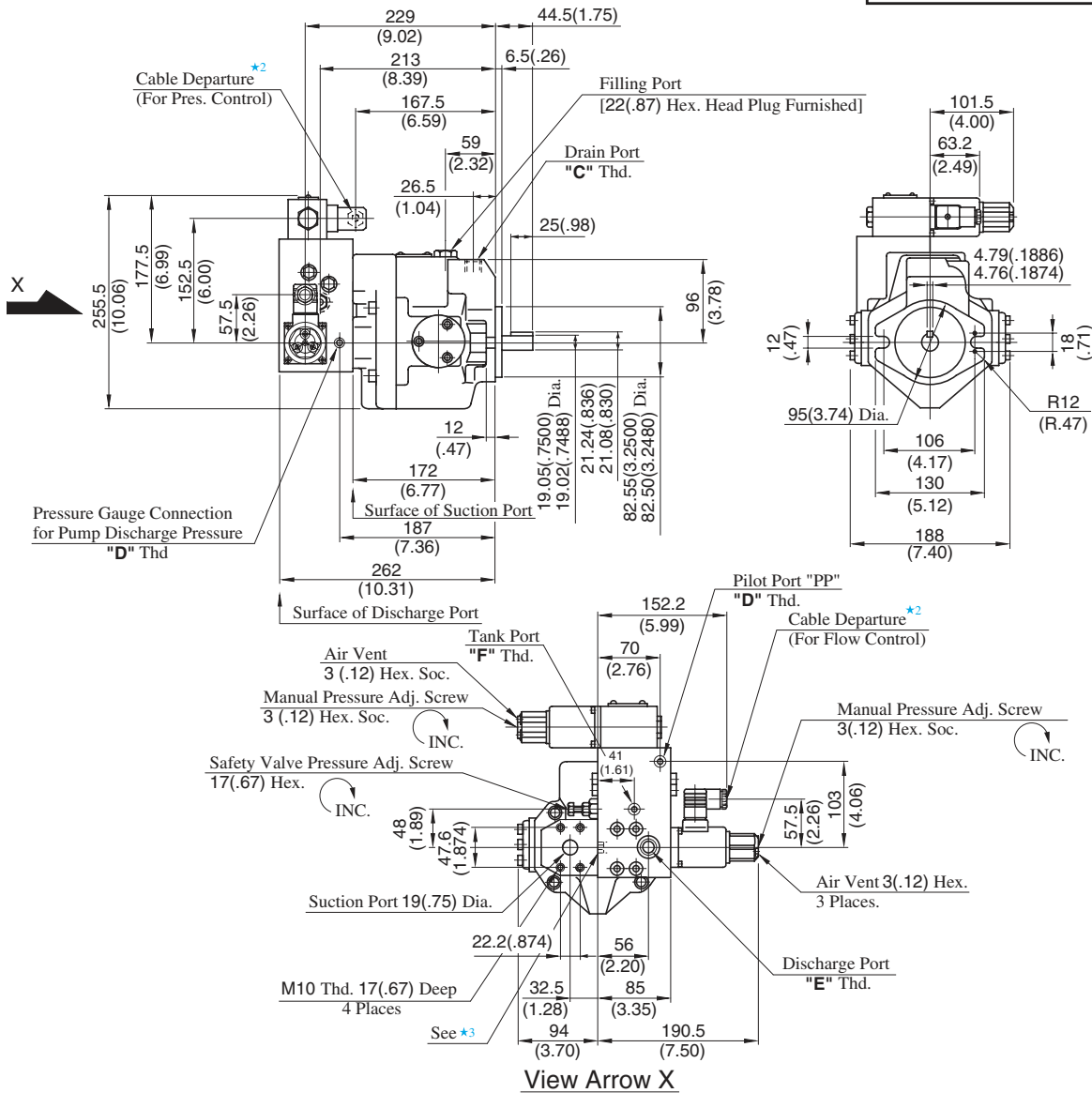

Model Numbers	"C" Thd.	"D" Thd.	"E" Thd.	"F" Thd.
A16/A22-F-R-04-*K-32	Rc 3/8	Rc 1/4	G 3/8*1	Rc 1/4
A16/A22-F-R-04-*K-3280	3/8 BSP.F	1/4 BSP.Tr	3/8 BSP.F	1/4 BSP.F

★ 1. Detail of Discharge Port  
 [For Japanese Standard]

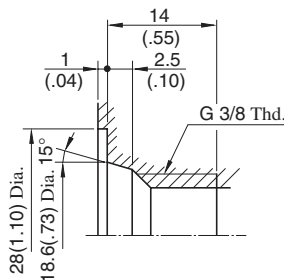

★ 2. Cable Applicable:  
 Outside Dia.....8-10 mm (.31-.39 IN.)  
 Conductor Area.....Not Exceeding 1.5 mm<sup>2</sup> (.0023 Sq. IN.)

★ 3. Do not touch the screw because it is adjusted at the time of shipment.

**● Foot Mounting Type**

Mounting bracket is common to that of pressure compensator model.  
 Refer to page 45 for the dimensions of mounting bracket.



Flange Mtg. : A37-F-R-04-\*-K-32/3280

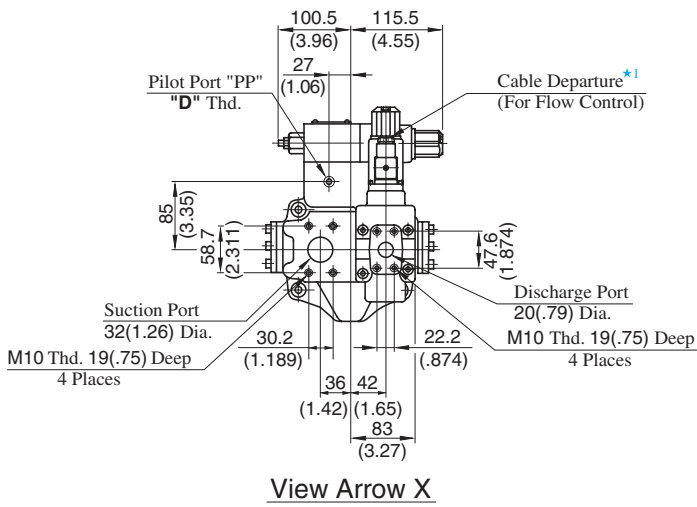
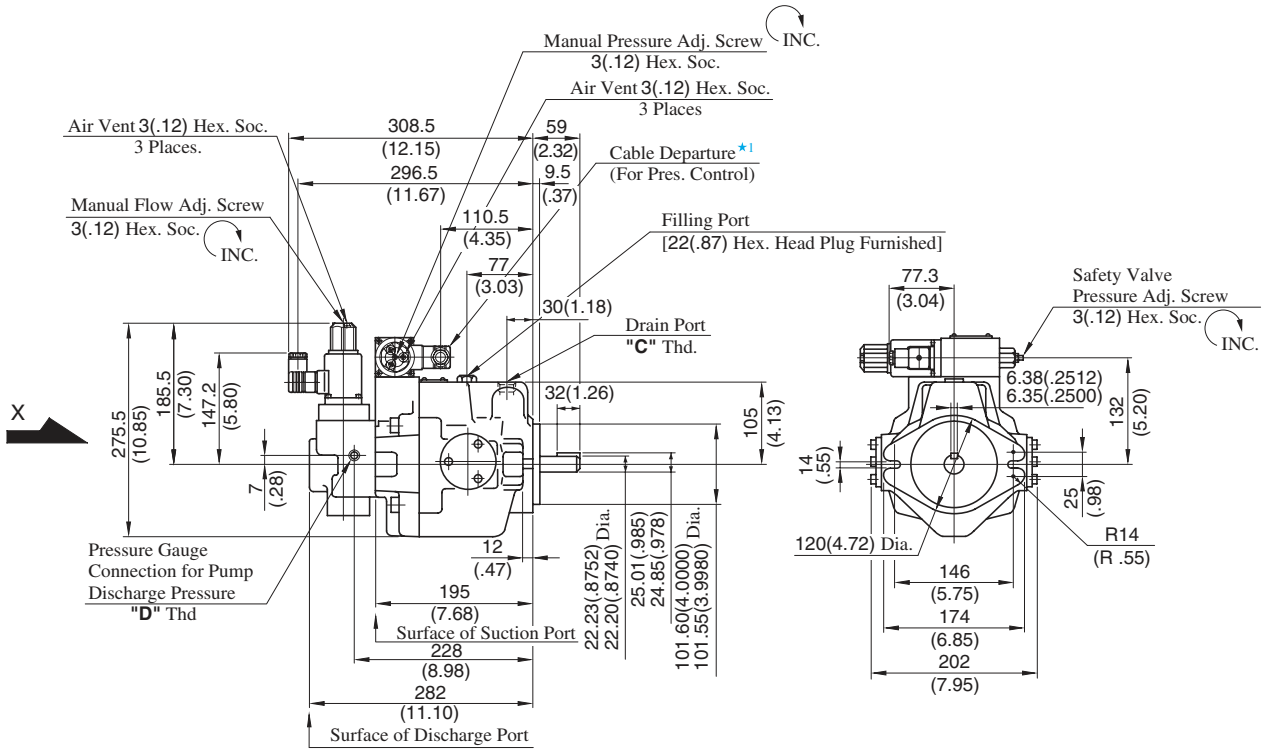

★ 1. Cable Applicable:  
 Outside Dia.....8-10 mm (.31-.39 IN.)  
 Conductor Area.....Not Exceeding 1.5 mm<sup>2</sup> (.0023 Sq. IN.)

Model Numbers	"C" Thd.	"D" Thd.
A37-F-R-04-*-K-32	Rc 1/2	Rc 1/4
A37-F-R-04-*-K-3280	1/2 BSP.F	1/4 BSP.Tr

DIMENSIONS IN MILLIMETRES (INCHES)

Foot Mtg. : A37-L-R-04-\*-K-32/3280

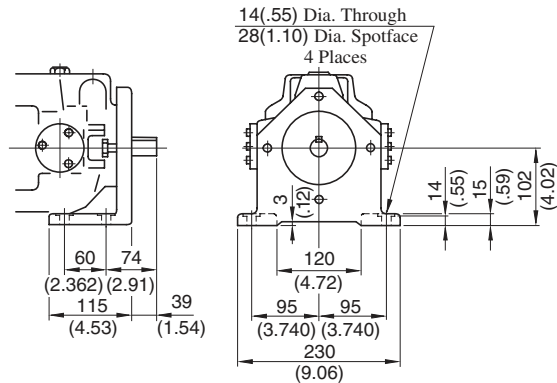

• For other dimensions, refer to "Flange Mtg.".

**Flange Mtg. : A56-F-R-04-\*-K-32/3280**

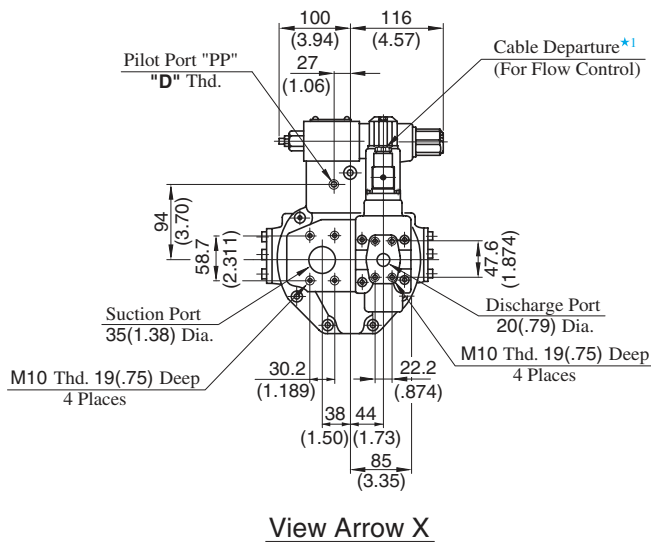
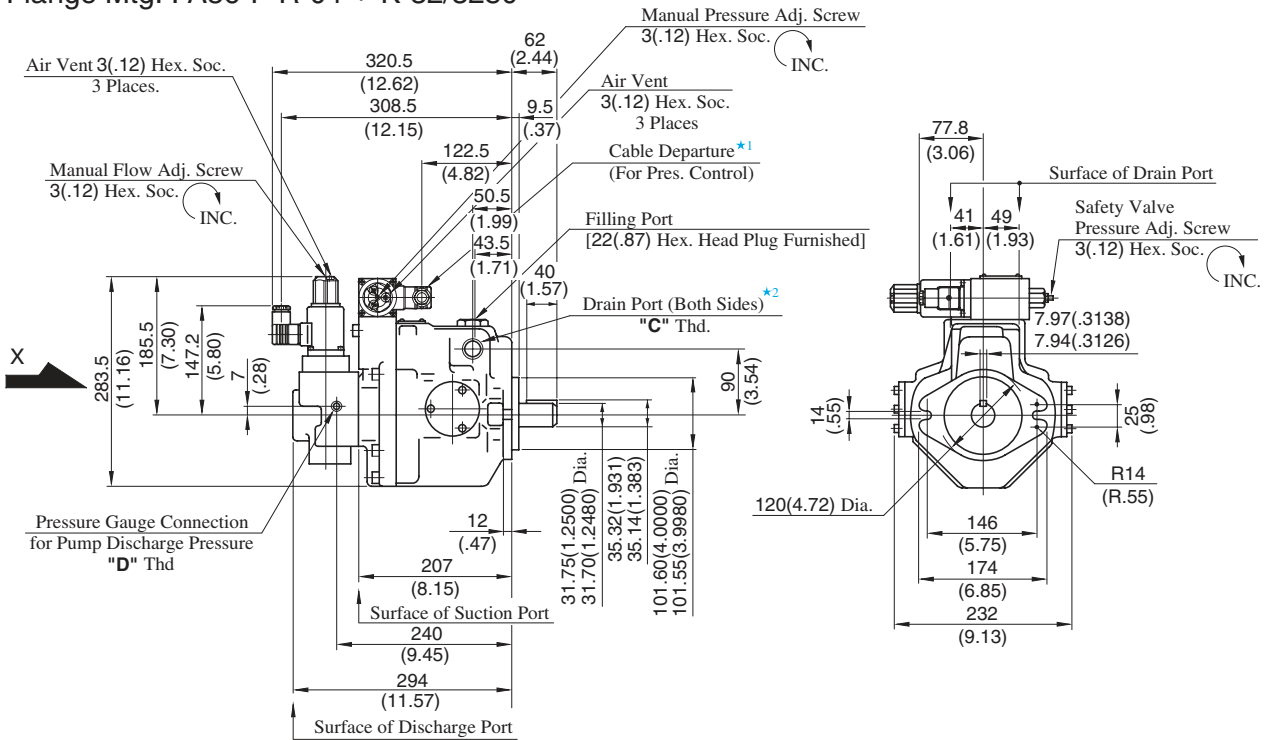

- ★ 1. Cable Applicable:  
Outside Dia.....8-10 mm (.31-.39 IN.)  
Conductor Area.....Not Exceeding 1.5 mm<sup>2</sup> (.0023 Sq. IN.)
- ★ 2. Use either port of two drain ports at your option.  
Keep the remaining port plugged.

Model Numbers	"C" Thd.	"D" Thd.
A56-F-R-04-*-K-32	Rc 3/4	Rc 1/4
A56-F-R-04-*-K-3280	3/4 BSP.F	1/4 BSP.Tr

**DIMENSIONS IN MILLIMETRES (INCHES)**

**Foot Mtg. : A56-L-R-04-\*-K-32/3280**

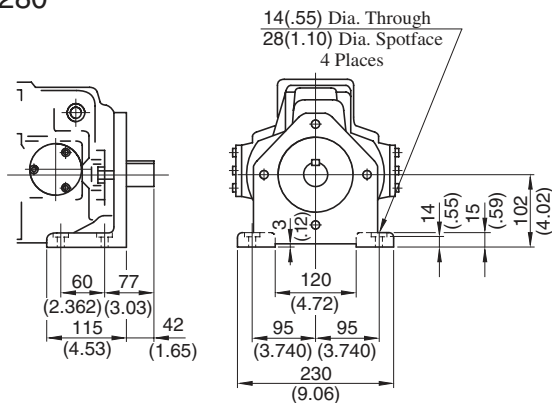

• For other dimensions, refer to "Flange Mtg. "

Flange Mtg. : A70-FR04\*S-60/6080

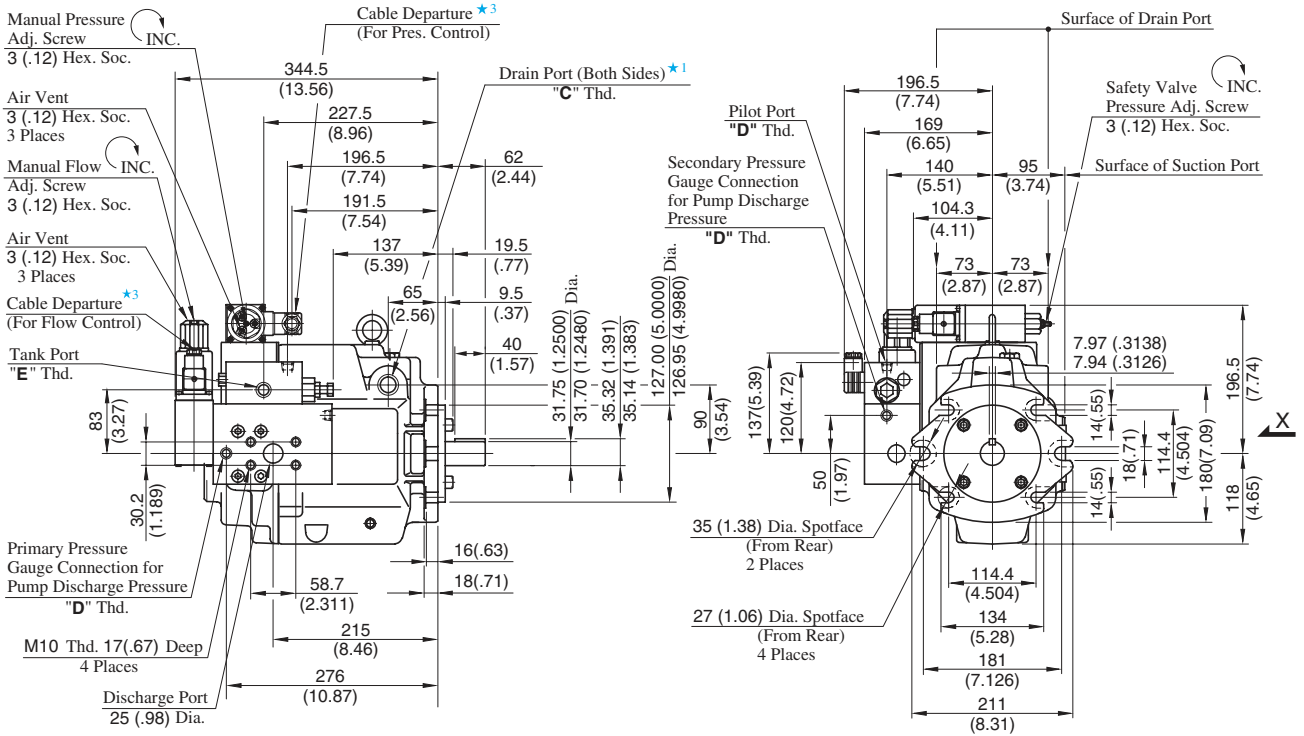

- ★ 1. Use either port of two drain ports at your option. Keep the remaining port plugged.
- ★ 2. Case drain port is available for use when draining hydraulic fluid from pump casing.
- ★ 3. Cable Applicable:  
Outside Dia.....8-10 mm (.31-.39 IN.)  
Conductor Area.....Not Exceeding 1.5 mm<sup>2</sup> (.0023 Sq. IN.)

Model Numbers	"C" Thd.	"D" Thd.	"E" Thd.
A70-FR04*S-60	Rc 3/4	Rc 1/4	Rc 3/8
A70-FR04*S-6080	3/4 BSP.F	1/4 BSP. Tr	3/8 BSP. F

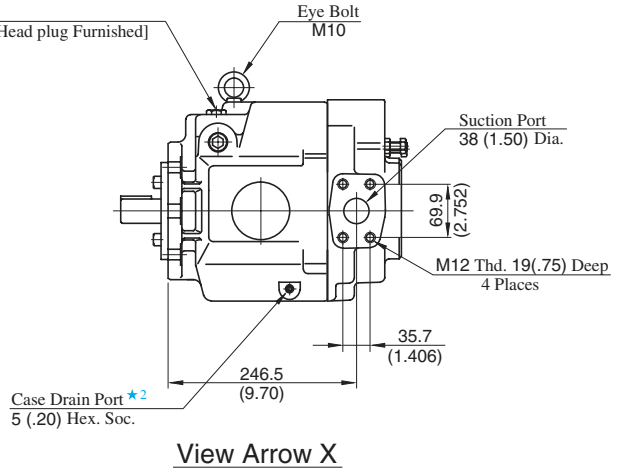

View Arrow X

DIMENSIONS IN MILLIMETRES (INCHES)

Foot Mtg.: A70-LR04\*S-60/6080

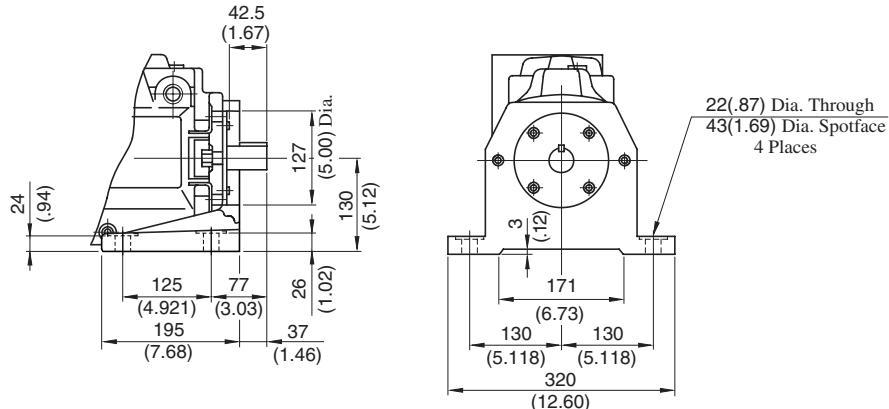

• For other dimensions, refer to "Flange Mtg.".

**Flange Mtg. : A90-FR04\*S-60/6080**

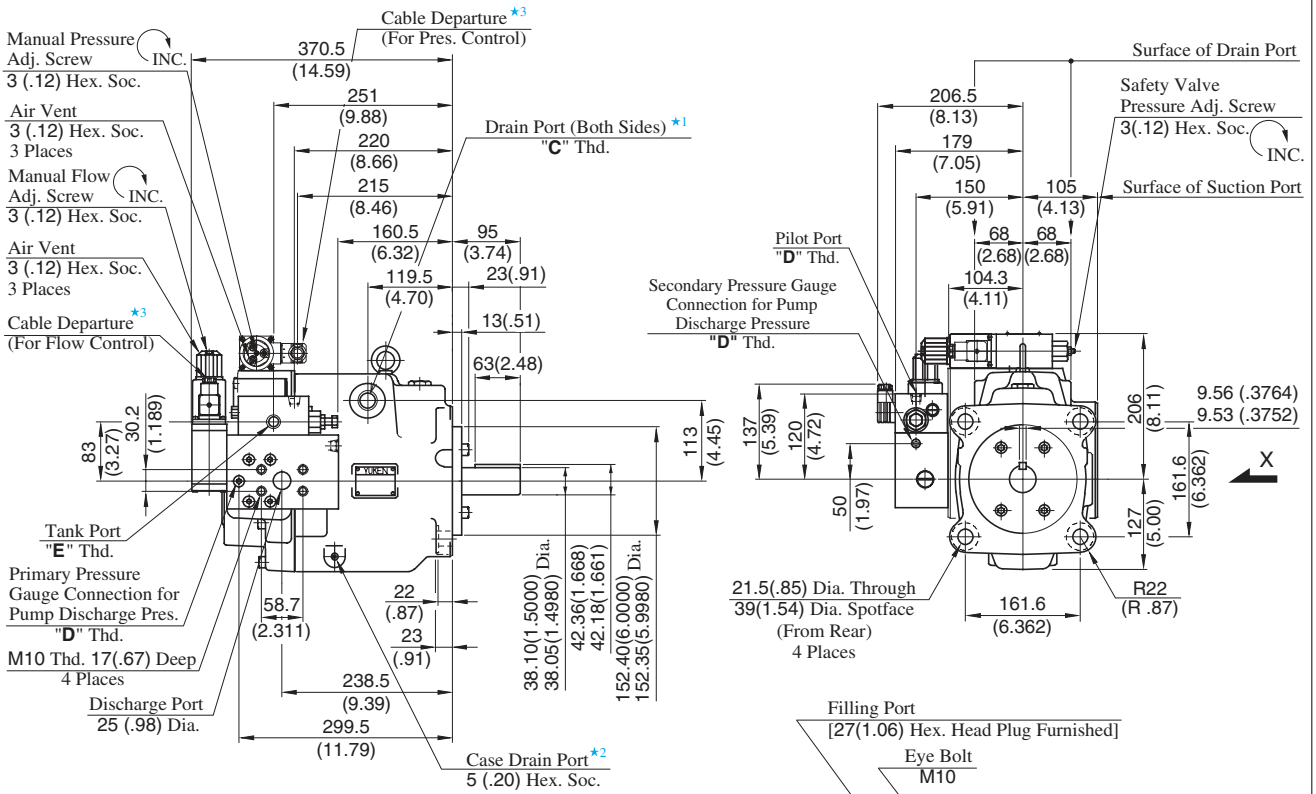

- ★ 1. Use either port of two drain ports at your option. Keep the remaining port plugged.
- ★ 2. Case drain port is available for use when draining hydraulic fluid from pump casing.
- ★ 3. Cable Applicable:  
 Outside Dia.....8-10 mm (.31-.39 IN.)  
 Conductor Area.....Not Exceeding 1.5 mm<sup>2</sup> (.0023 Sq. IN.)

Model Numbers	"C" Thd.	"D" Thd.	"E" Thd.
A90-FR04*S-60	Rc 3/4	Rc 1/4	Rc 3/8
A90-FR04*S-6080	3/4 BSP.F	1/4 BSP. Tr	3/8 BSP. F

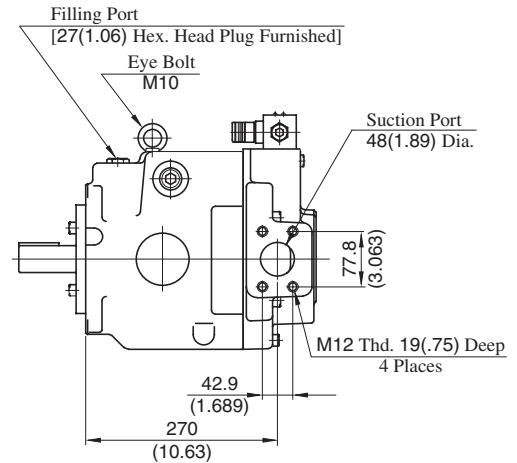

**View Arrow X**

**DIMENSIONS IN MILLIMETRES (INCHES)**

**Foot Mtg.: A90-LR04\*S-60/6080**

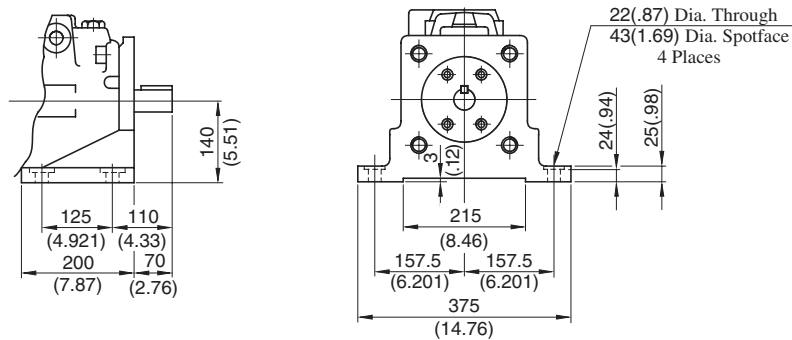

• For other dimensions, refer to "Flange Mtg.".

Flange Mtg. : A145-FR04\*S-60/6080

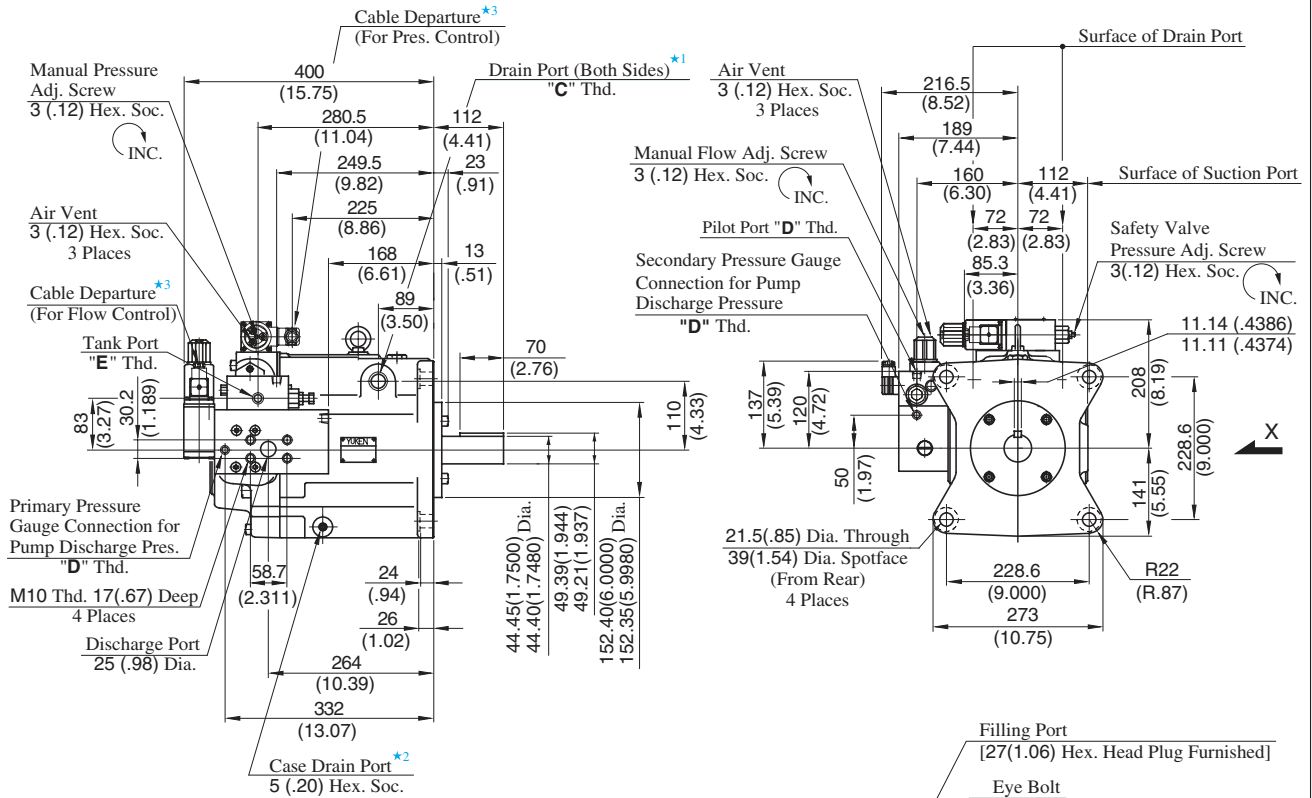

- ★ 1. Use either port of the two drain ports at your option. Keep the remaining port plugged.
- ★ 2. Case drain ports are available for use when draining hydraulic fluid from pump casing.
- ★ 3. Cable Applicable:  
Outside Dia.....8-10 mm (.31-.39 IN.)  
Conductor Area.....Not Exceeding 1.5 mm<sup>2</sup> (.0023 Sq. IN.)

Model Numbers	"C" Thd.	"D" Thd.	"E" Thd.
A145-FR04*S-60	Rc 3/4	Rc 1/4	Rc 3/8
A145-FR04*S-6080	3/4 BSP.F	1/4 BSP. Tr	3/8 BSP. F

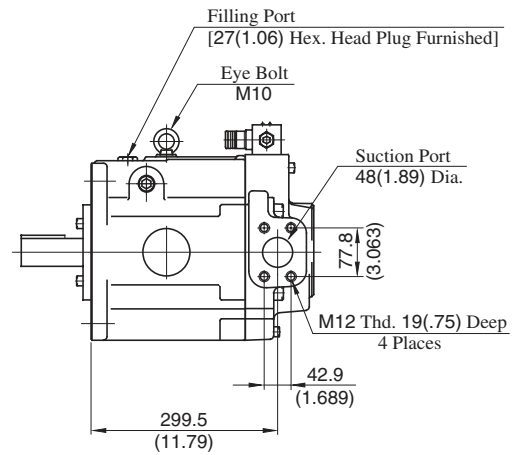

View Arrow X

DIMENSIONS IN MILLIMETRES (INCHES)

Foot Mtg.: A145-LR04\*S-60/6080

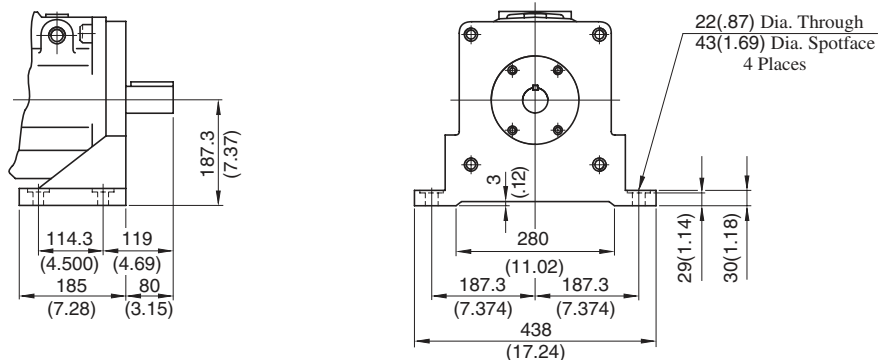

• For other dimensions, refer to "Flange Mtg.".

# "A" Series Variable Displacement Piston Pumps – Single Pump, Electro-Hydraulic Proportional pressure & Flow Control Type

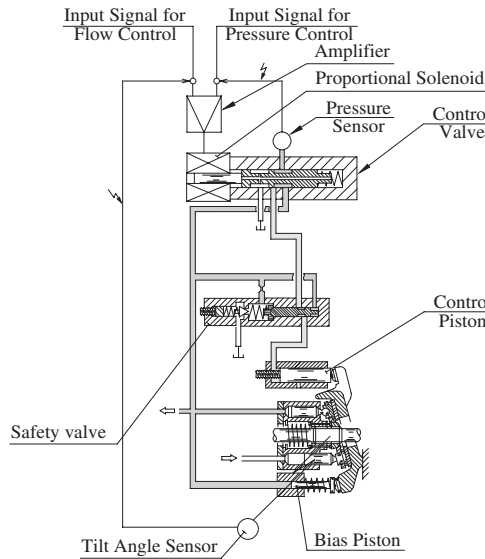

## Performance Characteristics

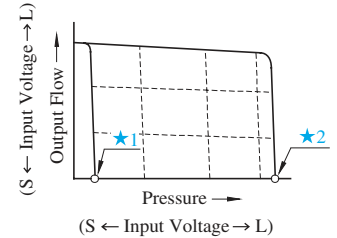

- ★1. Unloading pressure when input signal is 0 V.
- ★2. Safety valve setting pressure

## Graphic Symbols

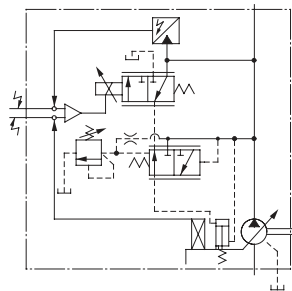

A16/A22/A37/A56

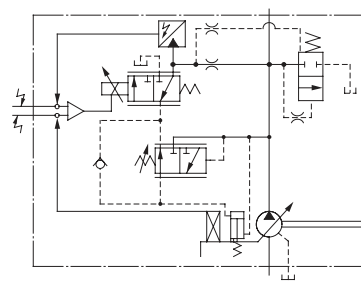

A70/A90/A145

## Model Number Designation

A70	-F	R	04E	16	M	A	-60	-60	*
Series Number	Mounting	Direction of Rotation	Control Type	Control Pressure at Input Signal is 5 V	Unit of Control Pressure	Type of <sup>★2</sup> Outboard Pump	Compensation Number <sup>★3</sup>	Design Number	Design Std.
<b>A16</b> (15.8 cm <sup>3</sup> /rev)	<b>F:</b> Flange Mtg.	(Viewed from Shaft End)	<b>04E:</b> Proportional Pressure & Flow Control Type	Use the same measure of the control pressure as shown on the right, 6.9 MPa specify within the range of maximum operating pressure	<b>M:</b> MPa <b>P:</b> PSI	<b>None</b> <sup>★2</sup>	<b>06</b>	<b>42</b>	Refer to <sup>★4</sup>
<b>A22</b> (22.2 cm <sup>3</sup> /rev)							<b>11</b>	<b>42</b>	
<b>A37</b> (36.9 cm <sup>3</sup> /rev)							<b>01</b>	<b>42</b>	
<b>A56</b> (56.2 cm <sup>3</sup> /rev)							<b>02</b>	<b>42</b>	
<b>A70</b> (70.0 cm <sup>3</sup> /rev)	<b>L:</b> Foot Mtg.	<b>R:</b> Clockwise (Normal) <sup>★1</sup>				<b>A:</b> <sup>★2</sup> <b>B:</b> <sup>★2</sup>	<b>60</b>	<b>60</b>	
<b>A90</b> (91.0 cm <sup>3</sup> /rev)							<b>60</b>	<b>60</b>	
<b>A145</b> (145.0 cm <sup>3</sup> /rev)							<b>60</b>	<b>60</b>	

★1. Available to supply pump with anti-clockwise rotation. Consult Yuken for details.

★2. These pumps, except A16 and A22 types, can be connected to outboard pumps.

- A37/A56 type (outboard pump connection symbol: **None**): spigot diameter: 82.55 mm (3.250 in.) (A16, A22, and PV2R1).

- A70/A90/A145 type (outboard pump connection symbol: **"A"**): spigot diameter: 82.55 mm (3.250 in.) (A16, A22, and PV2R1).

- A70/A90/A145 type (outboard pump connection symbol: **"B"**): spigot diameter: 101.6 mm (4.000 in.) (A37 and PV2R2).

★3. Amplifier Compensation Number may differ according to the main machine conditions. Consult Yuken for detail.

★4. Design Standards: None ..... Japanese Standard "JIS"

80 ..... European Design Standard

• Consult Yuken when "N. American Design Standard" is required.



## Specifications

Descriptions		Model Numbers	A16	A22	A37	A56	A70	A90	A145
Geometric Displacement		cm <sup>3</sup> /rev (cu. in./rev)	15.8 (.964)	22.2 (1.355)	36.9 (2.25)	56.2 (3.43)	70.0 (4.27)	91.0 (5.55)	145.0 (8.85)
Operating Pressure MPa (PSI)		Rated <sup>*2</sup>	16 (2320)	16 (2320)	16 (2320)	16 (2320)	25 (3630)	25 (3630)	25 (3630)
		Intermittent <sup>*1</sup>	21 (3050)	16 (2320)	21 (3050)	21 (3050)	28 (4060)	28 (4060)	28 (4060)
Shaft Speed Range		r/min	600 - 1800						
Flow Control	Max. Flow <sup>*3</sup>	L/min (U.S. GPM)	28.4 (7.5)	40.0 (10.6)	66.4 (17.5)	101.0 (26.7)	126.0 (33.3)	163.0 (43.1)	261.0 (69.0)
	Min. Pres. Required for Flow Adj.	MPa (PSI)	2.0 (290) <sup>*4</sup>						
	Hysteresis		1 % or less						
	Repeatability		1 % or less						
	Input Signal		Max. Flow / 5 V DC						
Pressure Control	Min. Adjustment Pressure	MPa (PSI)	0.7 (100)						
	Hysteresis		1 % or less						
	Repeatability		1 % or less						
	Input Signal		Specified Control Pressure / 5 V DC						
Coil Resistance		[@ 20°C (68 °F)]	10						
Input Impedance			Flow Control : 10 kΩ Pressure Control : 10 kΩ						
Supply Electric Power			24 V DC (21 - 28 V Included Ripple)						
Power Input (Max.)		W	30						
Output Signal	Flow		5 V DC/Max. Flow						
	Pressure		5 V DC/Specified Control Pressure						
Alarm Signal Output (Open Collector)			Voltage : Max. 30 V DC Current : Max. 40 mA						
Ambient Temperature		°C (°F)	0 - 50 (32 - 122) (With Circulated Air)						
Approx. Mass kg (lbs.)	Flange Mtg.		20.5 (45.2)	20.5 (45.2)	32.0 (70.6)	39.0 (86.0)	64.0 (141)	76.5 (169)	96.4 (213)
	Foot Mtg.		22.7 (50.1)	22.7 (50.1)	36.3 (80.0)	43.3 (95.5)	76.0 (168)	97.0 (214)	121.4 (268)

- ★ 1. Whenever setting pressure, make sure the full cut-off pressure never exceeds the maximum intermittent pressure.
- ★ 2. When operating the pump exceeding the rated pressure, operating conditions are restricted.  
Refer to [page 33](#) for the details.
- ★ 3. Maximum flow differs to shaft speed.  
The value listed above indicates shaft speed of 1800 r/min.  
For other shaft speed calculate by the ratio of shaft speed.
- ★ 4. To secure the required minimum pressure, special sequence valves are available, to be directly installed at the discharge port of the pump. Consult Yuken for details.

## Pipe Flange Kits

For Pipe flange, refer to form of pressure compensator type on [page 34](#).

## Instructions

### Input Signal

The pump is on unload condition when the pump is operated without input signal voltage.

### Electric Source

Always turn off electric source whenever the connector for swash plate tilt angle sensor is removed.

### Compensation of Pump Maximum Regulated Flow at Frequency

If the same maximum flow is required at 50 Hz or 60 Hz, connect short plug in the amplifier to 60 Hz at the place where supplied frequency is 60 Hz. At this condition, maximum flow comes to the same value at 50 Hz.

If short plug is used at 60 Hz without making the change, maximum flow increased in proportion to frequency.

### Painting on Amp. Box and Solenoid

To maintain suitable radiation effect, the amp. Box and the solenoid of the control valve should not be painted.

**■ Outboard Pumps**

A37 to A145 type pumps, except A16 and A22, can be used as double pumps, by connecting an outboard pump on the cover side. See the table below for details.

**● Connectable Outboard Pump**

Outboard Pump Connection Symbol		Spigot Diameter for Connecting an Outboard Pump mm (in.)	Connectable Pump*
A37/A56	None	82.55 (2.500)	A16, A22, PV2R1
A70/A90/A145	"A"	101.6 (4.000)	A37, PV2R2
	"B"		

\* Connectable pumps shafts are involute-serrated design, not the standard parallel key slot design. For details, including pump dimensions and model numbers, consult Yuken.

**● Coupling**

Please use assembly part number when ordering coupling assemblies for shaft connections to outboard pumps.

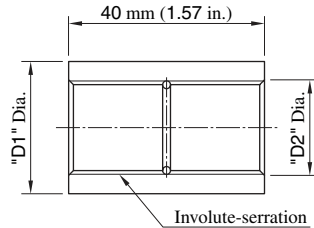

Outboard Pump Connection Symbol	Part Number of Coupling Ass'y	Dimensions mm (in.)		Serration Size (Nominal Dia. × No. of Teeth × Module)
		"D1"	"D2"	
A37/A56	None	27 (1.06)	19.5 (.77)	18.75 × 24 × 0.75
A70/A90/A145	"A"	36 (1.42)	26 (1.02)	25 × 24 × 1
	"B"			

**● Selecting an Outboard Pump Type**

The maximum torque of outboard pumps is limited by shaft and coupling assembly strength. When determining the outboard pump type, the value of the displacement times the pressure for a particular pump should not exceed the value shown in the table below.

Pump Model No.	① Inboard Pump and Outboard Pump (q1 × P1) + (q2 × P2)	② Outboard Pump q2 × P2	
		Outboard pump connection symbol "None"/"A" "B"	
A37	900(7963) and less	519(4592) and less	935(8272) and less
A56	1742(15413) and less		
A70	2408(21305) and less		
A90	4348(38470) and less		
A145	4739(41930) and less		

- q1, q2 : Displacement cm<sup>3</sup>/rev (cu.in./rev)
- P1, P2 : Pressure MPa (PSI)
- For selection of the appropriate pump, both values, ① and ②, should be satisfied.

**■ Attachment**

**● Amplifier**

Pump Model Numbers	Amplifier Model Numbers	Control Pressure MPa (PSI)
A16-*R04E ★-06-42	SK1106-★-16-06-10	- 14.7 ( - 2132)
	SK1106-★-16-06-1001	14.7 - 19.6 (2132 - 2842)
	SK1106-★-16-06-1002	19.6 - 21.0 (2842 - 3045)
A22-*R04E ★-11-42	SK1106-★-22-11-10	- 14.7 ( - 2132)
	SK1106-★-22-11-1001	14.7 - 16.0 (2132 - 2320)
A37-*R04E ★-60-42	SK1106-★-37-60-10	- 14.7 ( - 2132)
	SK1106-★-37-60-1001	14.7 - 19.6 (2132 - 2842)
	SK1106-★-37-60-1002	19.6 - 21.0 (2842 - 3045)
A56-*R04E ★-60-42	SK1106-★-56-60-10	- 14.7 ( - 2132)
	SK1106-★-56-60-1001	14.7 - 19.6 (2132 - 2842)
	SK1106-★-56-60-1002	19.6 - 21.0 (2842 - 3045)
A70-*R04E ★*-60-60	SK1106-★-70-60-10	- 14.7 ( - 2132)
	SK1106-★-70-60-1001	14.7 - 19.6 (2132 - 2842)
	SK1106-★-70-60-1002	19.6 - 22.6 (2842 - 3277)
	SK1106-★-70-60-1003	22.6 - (3277 - )
A90-*R04E ★*-60-60	SK1106-★-91-60-10	- 14.7 ( - 2132)
	SK1106-★-91-60-1001	14.7 - 19.6 (2132 - 2842)
	SK1106-★-91-60-1002	19.6 - 22.6 (2842 - 3277)
	SK1106-★-91-60-1003	22.6 - (3277 - )
A145-*R04E ★*-60-60	SK1106-★-145-60-10	- 14.7 ( - 2132)
	SK1106-★-145-60-1001	14.7 - 19.6 (2132 - 2842)
	SK1106-★-145-60-1002	19.6 - 22.6 (2842 - 3277)
	SK1106-★-145-60-1003	22.6 - (3277 - )

- Note 1. The symbol "★", shown with pump and amplifier model numbers, is the control pressure at input signal of 5 V.
2. Cable for pump-amplifier connection is not included. See Page 85 for details on ordering cables.





Output Flow vs. Input Signal

● A16

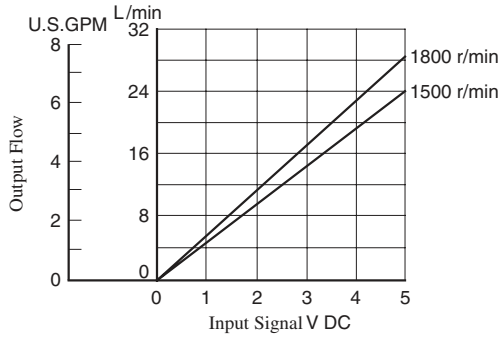

● A56

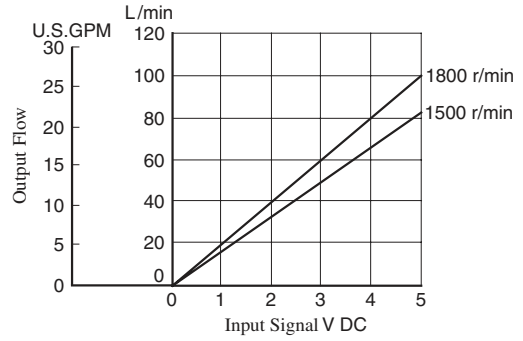

● A22

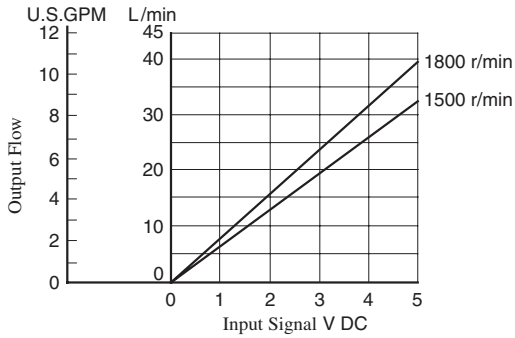

● A70

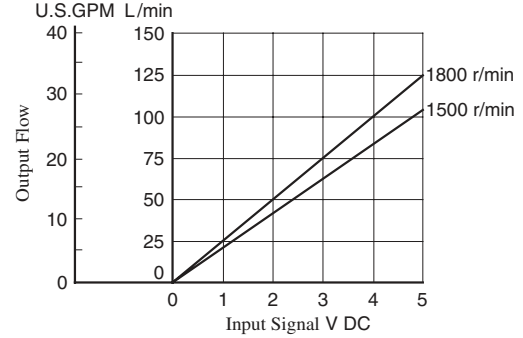

● A37

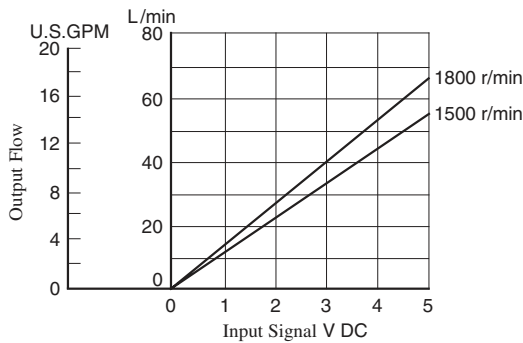

● A90

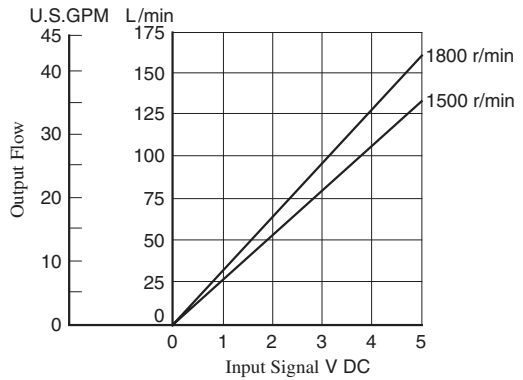

Note: Pump characteristics at 1800 r/min is the same as those at 1500 r/min where frequency is compensated. (Refer to page 75.)

● A145

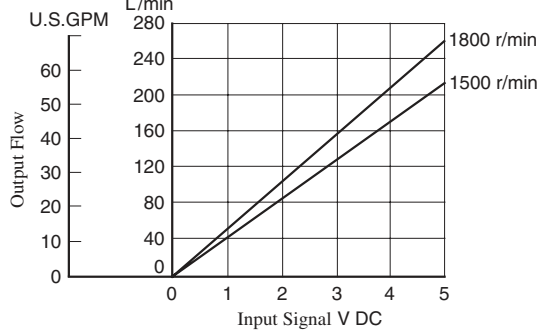

Full Cut-off Pres. vs. Input Signal

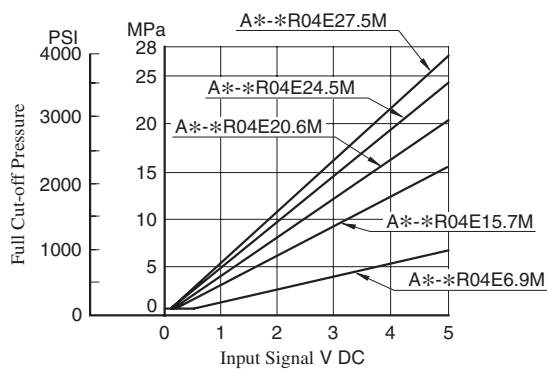

Refer to page 37 to 43 for performance characteristics of pressure compensator type excluding characteristics appeared on this catalogue.

Flange Mtg. : A16-FR04E\*-06-42/4280  
A22-FR04E\*-11-42/4280

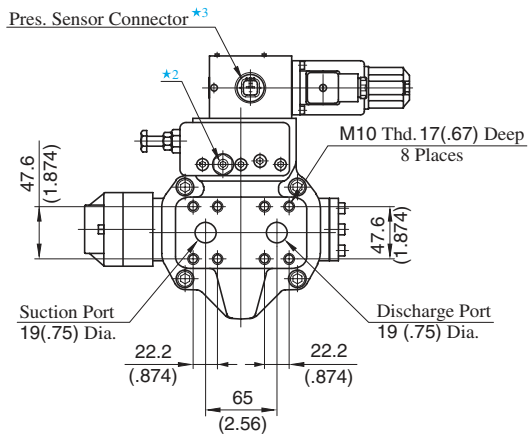
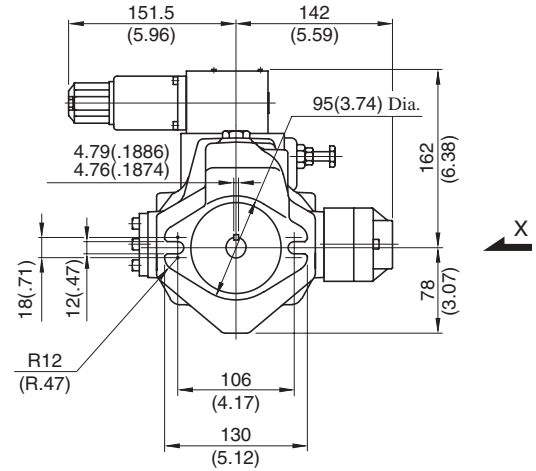
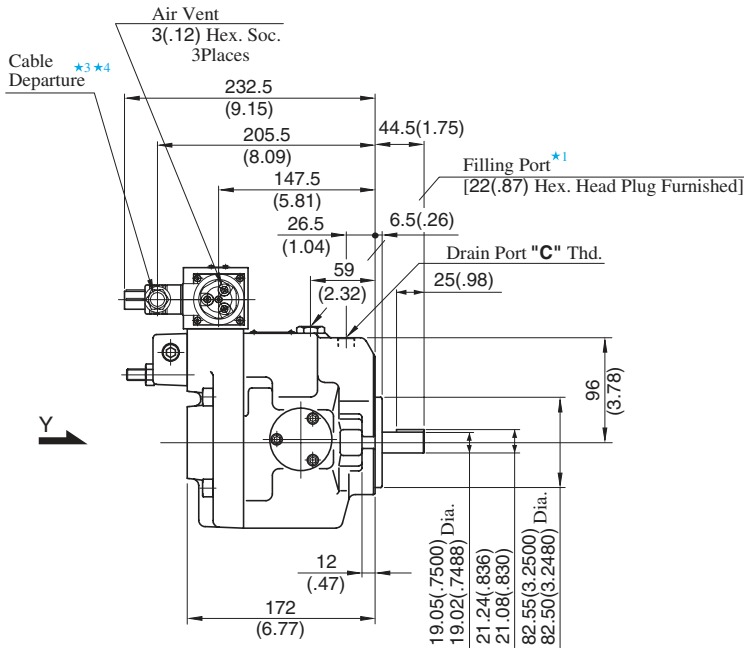

View Arrow Y

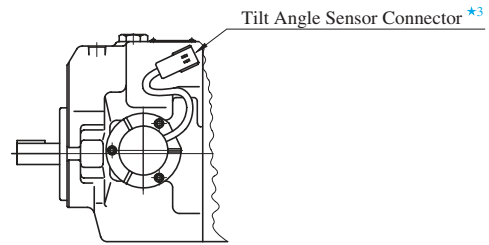

View Arrow X

- ★ 1. Install the pump so that the "Filling Port" is at the top.
- ★ 2. Do not touch the screw because it is adjusted at the time of shipment.
- ★ 3. For cable connection with amplifiers, see [page 85](#).
- ★ 4. Cable Applicable:  
Outside Dia. .... 8-10mm(.31-.39 IN.)  
Conductor Area..... Not Exceeding 1.5mm<sup>2</sup>(.0023 Sq. IN.)

Model Numbers	"C" Thd.
A16/A22-FR04E*-*-42	Rc 3/8
A16/A22-FR04E*-*-4280	3/8 BSP.F

**DIMENSIONS IN  
MILLIMETRES (INCHES)**

● **Foot Mounting Type**

Mounting bracket is common to that of pressure compensator model.  
Refer to [page 45](#) for the dimensions of mounting bracket.

Flange Mtg. : A37-FR04E\*-01-42/4280

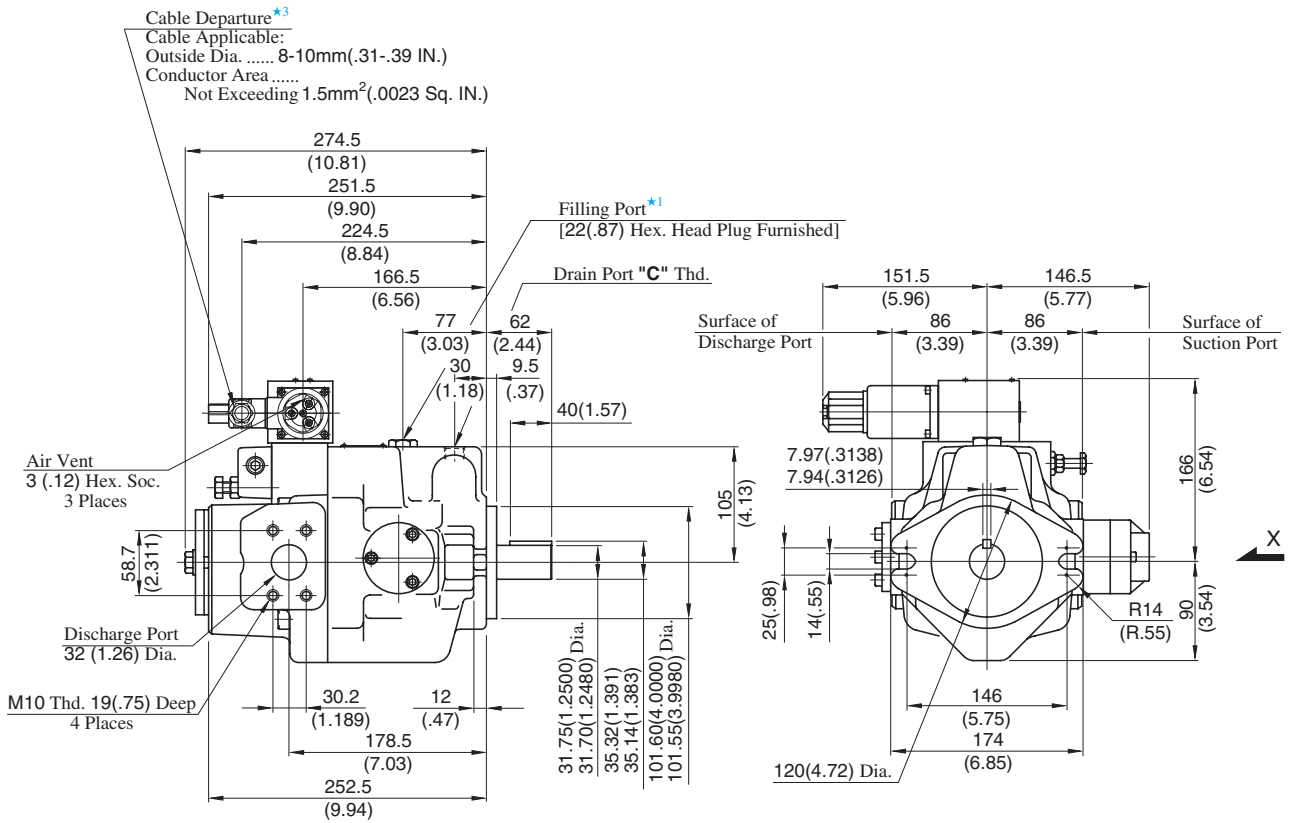

- ★ 1. Install the pump so that the "Filling Port" is at the top.
- ★ 2. Do not touch the screw because it is adjusted at the time of shipment.
- ★ 3. For cable connection with amplifiers, see page 85.

Model Numbers	"C" Thd.
A37-FR04E*-01-42	Rc 1/2
A37-FR04E*-01-4280	1/2 BSP.F

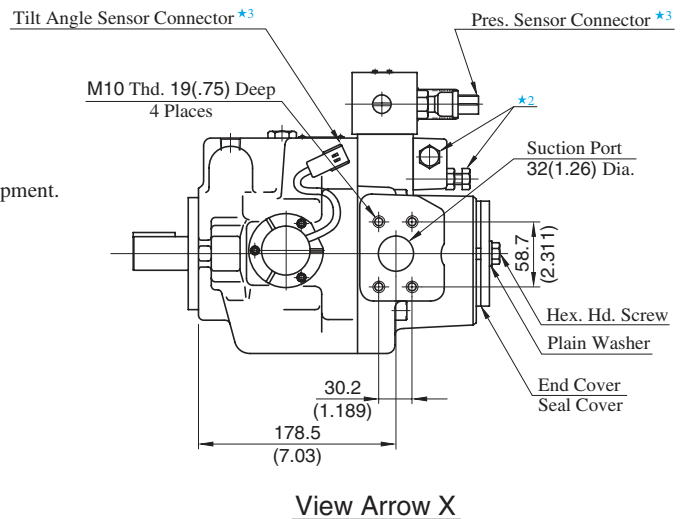

DIMENSIONS IN MILLIMETRES (INCHES)

● Foot Mounting Type

Mounting bracket is common to that of pressure compensator model.  
 Refer to page 46 for the dimensions of mounting bracket.

Flange Mtg. : A56-FR04E\*-02-42/4280

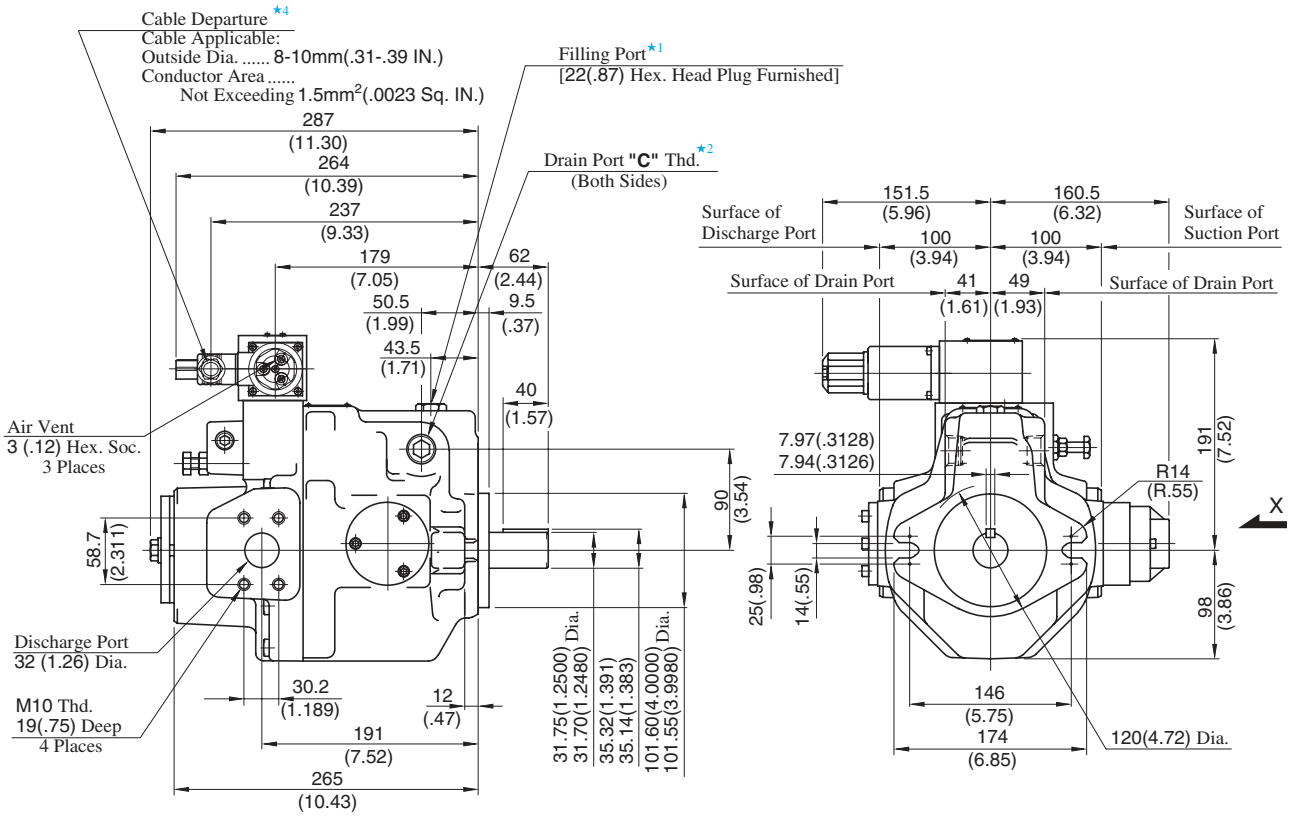

- ★ 1. Install the pump so that the "Filling Port" is at the top.
- ★ 2. Use either port of two drain ports at your option. Keep the remaining port plugged.
- ★ 3. Do not touch the screw because it is adjusted at the time of shipment.
- ★ 4. For cable connection with amplifiers, see [page 85](#).

Model Numbers	"C" Thd.
A56-FR04E*-02-42	Rc 3/4
A56-FR04E*-02-4280	3/4 BSP.F

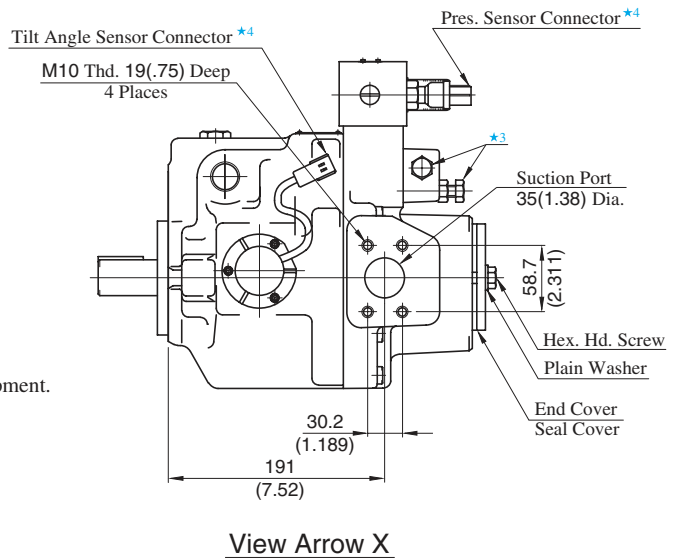

**DIMENSIONS IN MILLIMETRES (INCHES)**

● **Foot Mounting Type**

Mounting bracket is common to that of pressure compensator model.  
 Refer to [page 47](#) for the dimensions of mounting bracket.

Flange Mtg. : A70-FR04E\*\*-60-60/6080

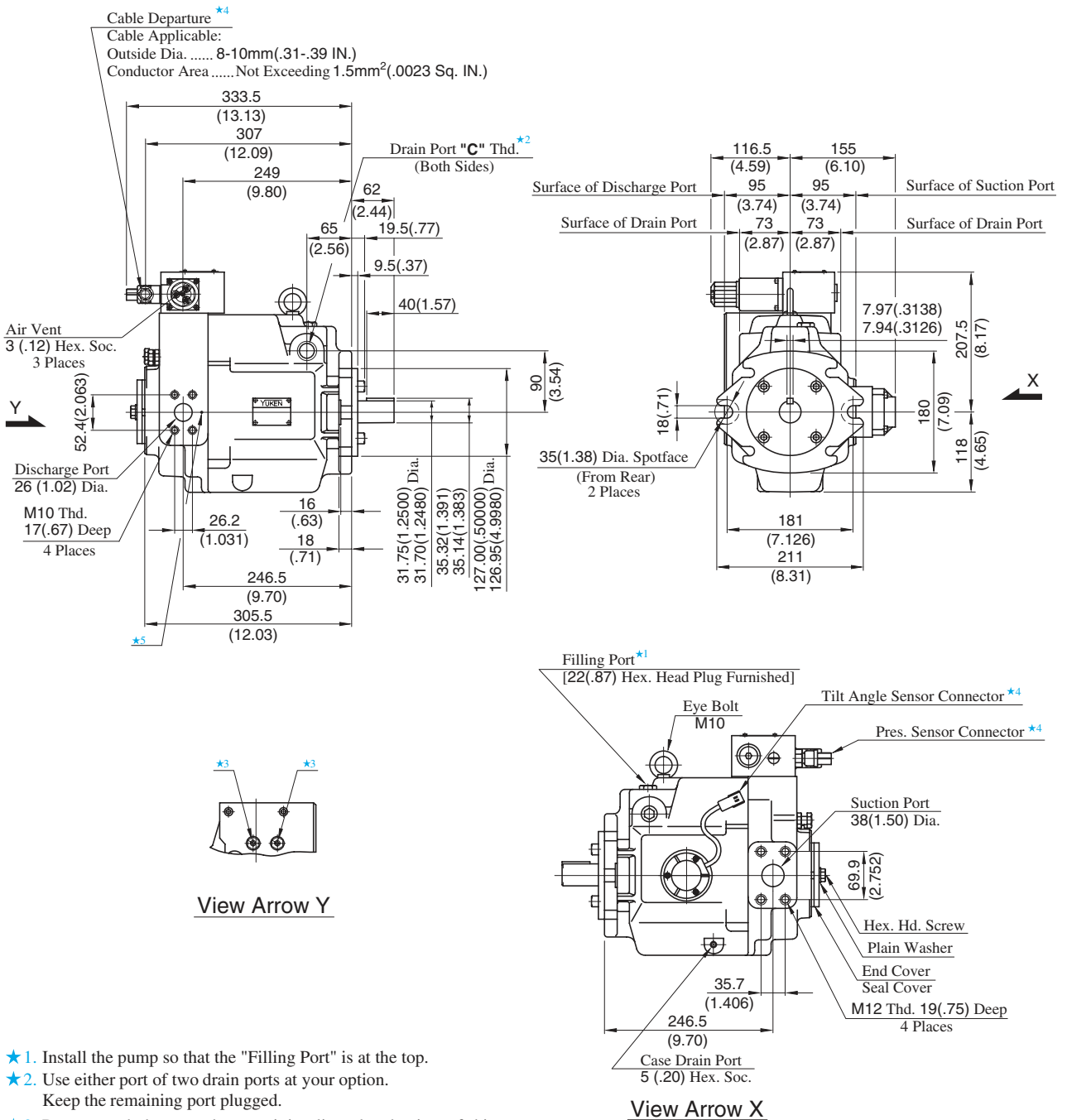

- ★ 1. Install the pump so that the "Filling Port" is at the top.
- ★ 2. Use either port of two drain ports at your option.  
Keep the remaining port plugged.
- ★ 3. Do not touch the screw because it is adjusted at the time of shipment.
- ★ 4. For cable connection with amplifiers, see page 85.
- ★ 5. If you do not use the special sequence valve, plug the port (FP-SC-1/32).

DIMENSIONS IN MILLIMETRES (INCHES)

● Foot Mounting Type

Mounting bracket is common to that of pressure compensator model.  
Refer to page 48 for the dimensions of mounting bracket.

Flange Mtg. : A90-FR04E\*\*60-60/6080

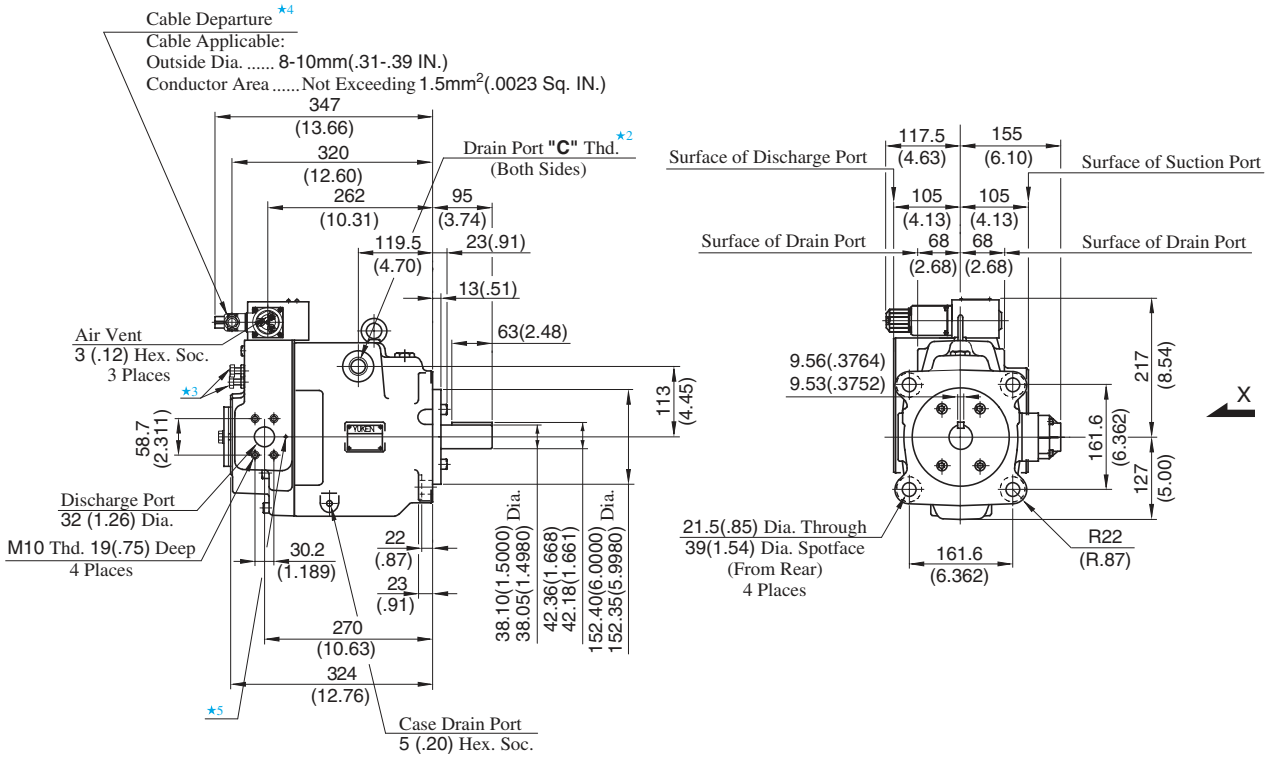

- ★ 1. Install the pump so that the "Filling Port" is at the top.
- ★ 2. Use either port of two drain ports at your option. Keep the remaining ports plugged.
- ★ 3. Do not touch the screw because it is adjusted at the time of shipment.
- ★ 4. For cable connection with amplifiers, see page 85.
- ★ 5. If you do not use the special sequence valve, plug the port (FP-SC-1/32).

Model Numbers	"C" Thd.
A90-FR04E**60-60	Rc 3/4
A90-FR04E**60-6080	3/4 BSP.F

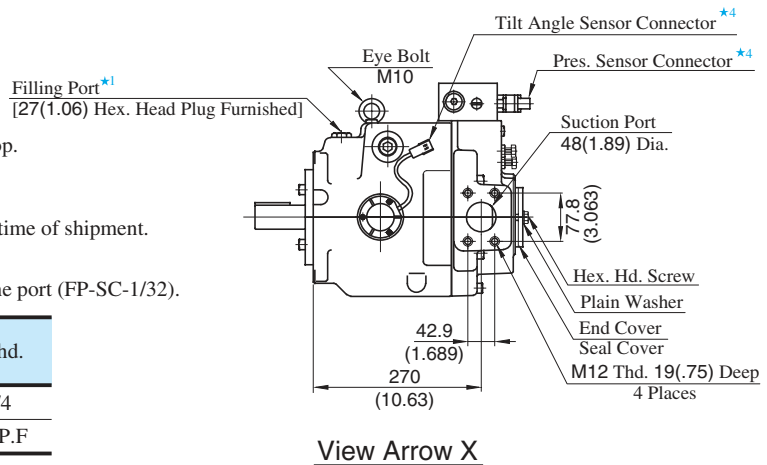

DIMENSIONS IN  
MILLIMETRES (INCHES)

● **Foot Mounting Type**

Mounting bracket is common to that of pressure compensator model.  
 Refer to page 49 for the dimensions of mounting bracket.

Flange Mtg. : A145-FR04E\*\*\*-60-60/6080

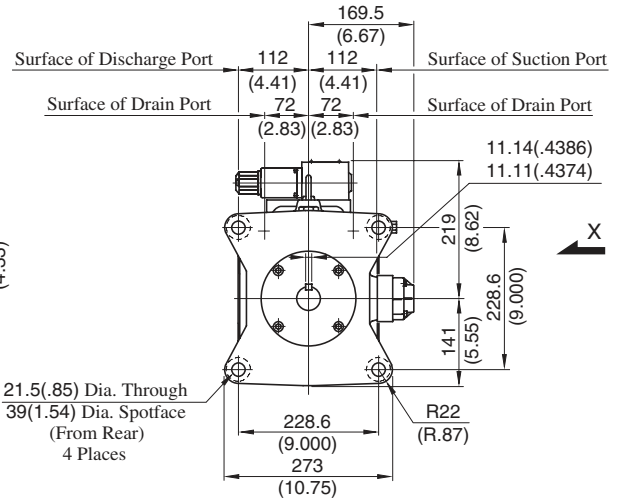
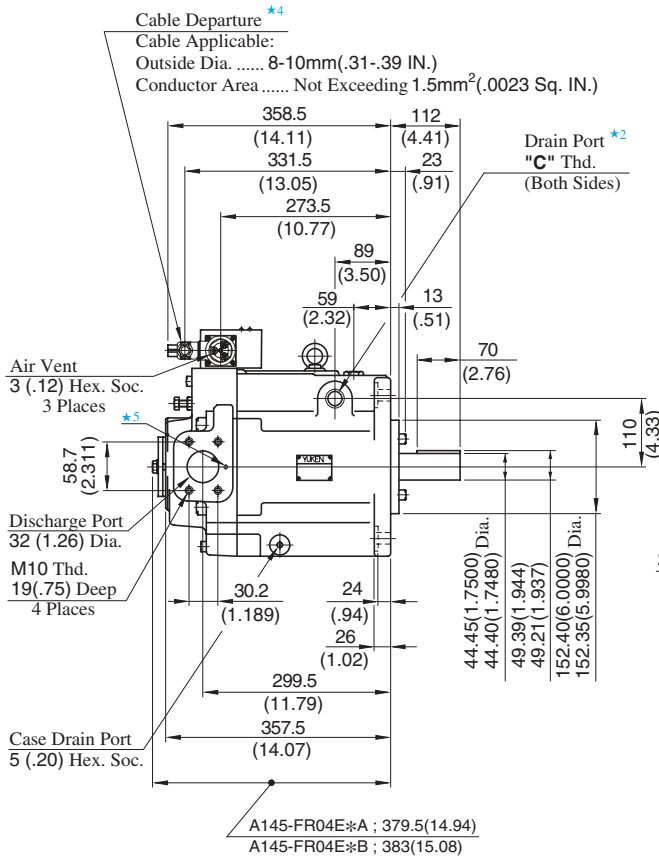

- ★ 1. Install the pump so that the "Filling Port" is at the top.
- ★ 2. Use either port of two drain ports at your option.  
Keep the remaining port plugged.
- ★ 3. Do not touch the screw because it is adjusted at the time of shipment.
- ★ 4. For cable connection with amplifiers, see page 85.
- ★ 5. If you do not use the special sequence valve, plug the port (FP-SC-1/32).

Model Numbers	"C" Thd.
A145-FR04E***-60-60	Rc 3/4
A145-FR04E***-60-6080	3/4 BSP.F

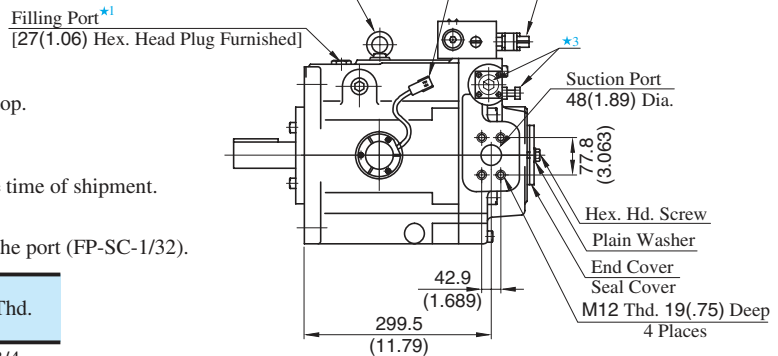

View Arrow X

DIMENSIONS IN MILLIMETRES (INCHES)

● Foot Mounting Type

Mounting bracket is common to that of pressure compensator model.  
Refer to page 50 for the dimensions of mounting bracket.

**Amplifiers for Electro-Hydraulic Proportional Pressure & Flow Control Type Pumps (SK1106-★-\*-\*-10\*\*)**

**Specifications**

Model No.	SK1106-★-*-*-10**
Description	
Applicable Coil Resistance	10 Ω [at 20 °C (68 °F)]
Input Impedance	10 kΩ (PIN, QIN)
Power Supply	24 V DC (21 - 28 V Included Ripple)
Power Input (Max.)	30 W
Input Signal	Max. Flow/5V (QIN), Specified Pres./5V (PIN)
Output Signal for Sensor Monitor	5V/Max. Flow (SMQ), 5V/Specified Pres. (SMP)
Ambient Temperature	0 - 50 °C (32 - 122 °F)
Approx. Mass	450 g (1.0 lbs.)

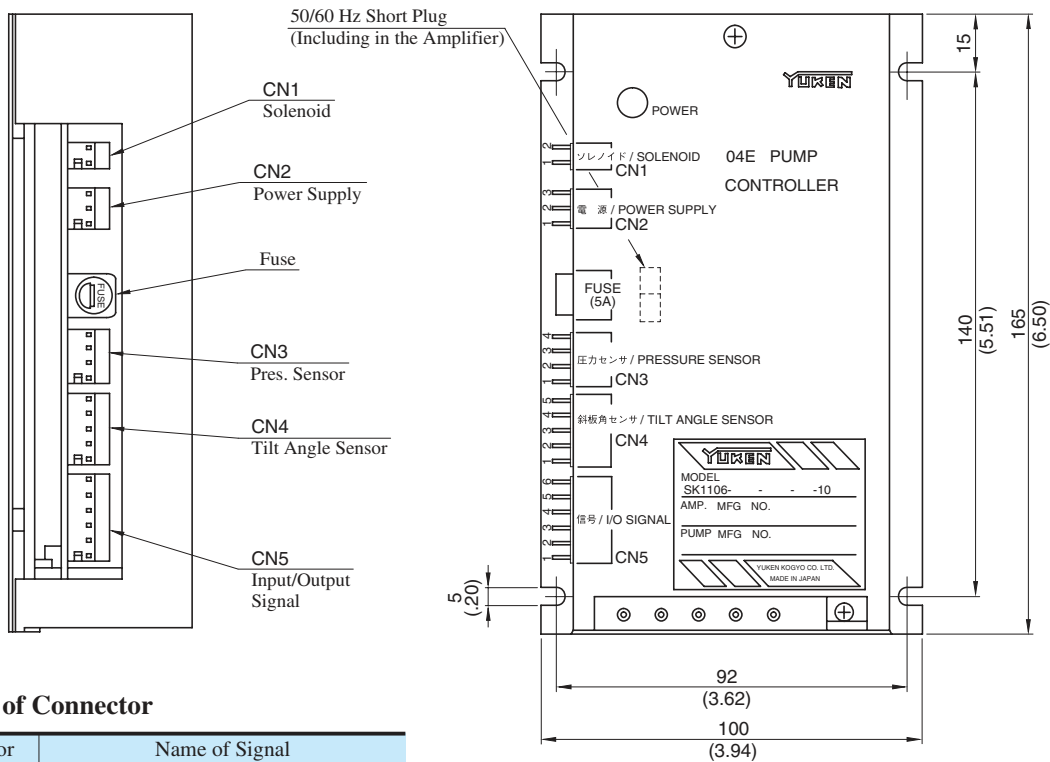

**Detail of Connector**

Connector	Name of Signal	
CN1 Solenoid	1	Output to pilot valve solenoid
	2	
CN2 Power Supply	1	0 [V] (0V )
	2	+24 [V] (24V)
	3	0 [V]
CN3 Pres. Sensor	1	+5 [V]
	2	0 [V]
	3	Input Signal - Sensor
	4	0 [V]
CN4 Tilt Angle Sensor	1	+8 [V]
	2	0 [V]
	3	Input Signal - Sensor
	4	0 [V]
	5	—
CN5 Input/Output Signal	1	Input Signal - Flow (Qin)
	2	Input Signal - Common (COM)
	3	Input Signal - Pres. (Pin)
	4	Output Signal - Sensor Monitor P (SMP)
	5	Output Signal - Sensor Monitor Q (SMQ)
	6	0 [V]

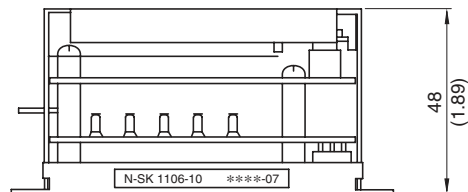

**DIMENSIONS IN MILLIMETRES (INCHES)**



### Cable Connection Between Pump and Amplifier

The cable connections between the proportional pilot valve and the sensor of the pump and the attached amplifier (SK1106) are shown below.

The cable assemblies are not included in the pump assembly. Purchase separately with model number described in the below table if required.

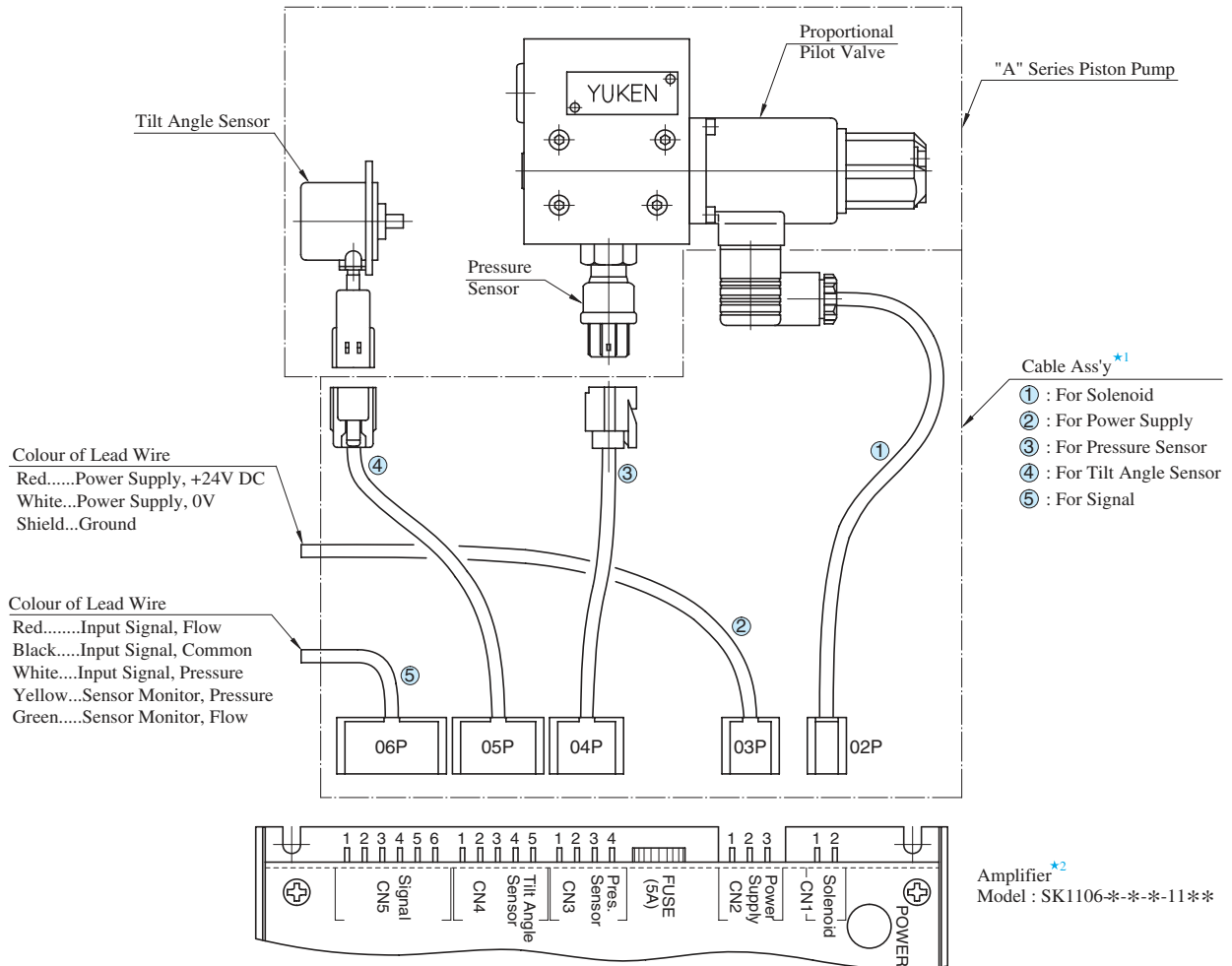

★ 1. Cable assemblies are available. When ordering, specify the cable ass'y model numbers from the table below.

Name of Cable Ass'y	Cable Ass'y Model Numbers		
	Approx. Length of Cable mm(ft.)		
	2000 (6.6)	5000 (16.4)	10000 (32.8)
① For Solenoid	SK1112-S-2-10	SK1112-S-5-10	SK1112-S-10-10
② For Power Supply	SK1112-V-2-10	SK1112-V-5-10	SK1112-V-10-10
③ For Pressure Sensor	SK1112-P-2-10	SK1112-P-5-10	SK1112-P-10-10
④ For Tilt Angle Sensor	SK1112-Q-2-10	SK1112-Q-5-10	SK1112-Q-10-10
⑤ For Signal	SK1112-C-2-10	SK1112-C-5-10	SK1112-C-10-10

★ 2. For the details of amplifier, see the [previous page](#).

# "A" Series Variable Displacement Piston Pumps – Single Pump, "OBE" Type Electro-Hydraulic Proportional Pressure & Flow Control Type

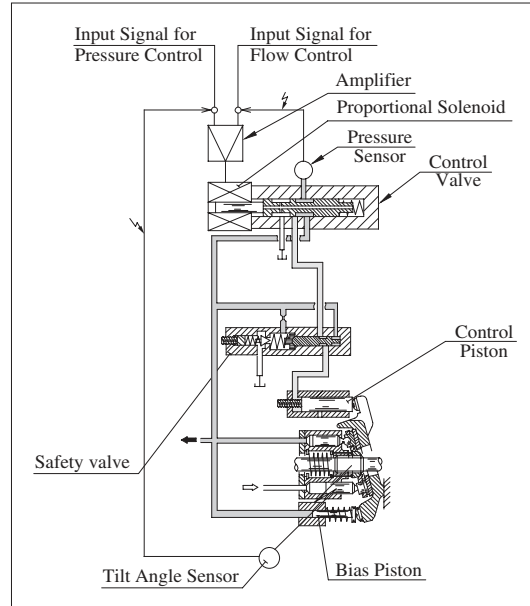
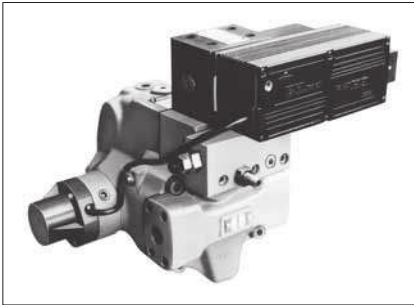

## Performance Characteristics

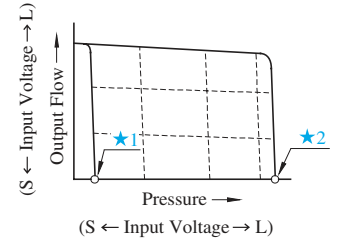

- ★ 1. Unloading pressure when input signal is 0 V.
- ★ 2. Safety valve setting pressure

## Graphic Symbols

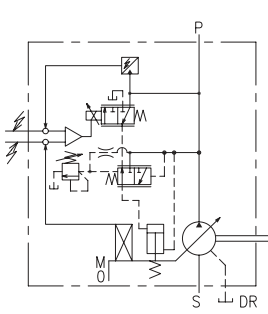

A16/A22/A37/A56

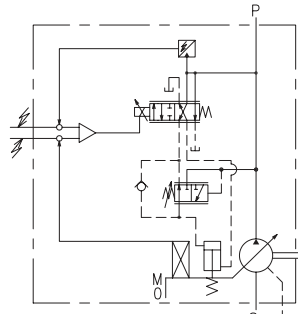

A70/A90/A145

## Example of Specified Control Pressure

Control Pressure Symbol (EX.)	Control Pressure at Input Signal is 5 V			
	kgf/cm <sup>2</sup>	MPa	PSI	
70	70	6.9	1000	
105	105	10.3	1500	
140	140	13.7	2000	
175	175	17.2	2500	
210	210	20.6	3000	
—	7M	71.4	7	1015
—	16M	163.2	16	2320
—	21M	214.2	21	3045

## Model Number Designation

A16	-F	R	04EH	70	R	S	-06	-42	*
Series Number	Mounting	Direction of Rotation	Control Type	Control Pressure at Input Signal is 5 V	Amplifier Direction	Port Position	Compensation Number <sup>★2</sup>	Design Number	Design Std.
<b>A16</b> (15.8 cm <sup>3</sup> /rev)	<b>F:</b> Flange Mtg.	(Viewed from Shaft End)	<b>04EH:</b> "OBE" Type Proportional Pressure & Flow Control Type	Specify Control Pressure between 6.9 MPa and Maximum Operating Pressure (Refer to above Table)	—	<b>S:</b> Side Port	<b>06</b>	<b>42</b>	Refer to ★3
<b>A22</b> (22.2 cm <sup>3</sup> /rev)							<b>11</b>	<b>42</b>	
<b>A37</b> (36.9 cm <sup>3</sup> /rev)							<b>01</b>	<b>42</b>	
<b>A56</b> (56.2 cm <sup>3</sup> /rev)							<b>02</b>	<b>42</b>	
<b>A70</b> (70.0 cm <sup>3</sup> /rev)							<b>60</b>	<b>60</b>	
<b>A90</b> (91.0 cm <sup>3</sup> /rev)	<b>L:</b> Foot Mtg.	<b>R:</b> Clockwise <sup>★1</sup> (Normal)			(Viewd from Shaft End)	<b>S:</b> Side Port	<b>60</b>	<b>60</b>	
<b>A145</b> (145.0 cm <sup>3</sup> /rev)							<b>60</b>	<b>60</b>	

- ★ 1. Available to supply pump with anti-clockwise rotation. Consult Yuken for details.
- ★ 2. Amplifier Compensation Number may differ according to the main machine conditions. Consult Yuken for detail.
- ★ 3. Design Standards: None.....Japanese Standard "JIS"  
950.....N.American Design Standard



Specifications

Descriptions		Model Numbers	A16	A22	A37	A56	A70	A90	A145
Geometric Displacement		cm <sup>3</sup> /rev (cu. in./rev)	15.8 (.964)	22.2 (1.355)	36.9 (2.25)	56.2 (3.43)	70.0 (4.27)	91.0 (5.55)	145.0 (8.85)
Operating Pressure MPa (PSI)		Rated <sup>*2</sup>	16 (2320)	16 (2320)	16 (2320)	16 (2320)	25 (3625)	25 (3625)	25 (3625)
		Intermittent <sup>*1</sup>	21 (3050)	16 (2320)	21 (3050)	21 (3050)	28 (4060)	28 (4060)	28 (4060)
Shaft Speed Range		r/min	600 - 1800						
Flow Control	Max. Flow <sup>*3</sup>	L/min (U.S. GPM)	28.4 (7.5)	40.0 (10.6)	66.4 (17.5)	101.2 (26.7)	126.0 (33.3)	163.0 (43.1)	261.0 (69.0)
	Min. Pres. Required for Flow Adj.	MPa (PSI)	2.0 (290)						
	Hysteresis		1 % or less						
	Repeatability		1 % or less						
	Input Signal		Max. Flow / 5 V DC						
Pressure Control	Min. Adjustment Pressure	MPa (PSI)	0.7 (100)						
	Hysteresis		1 % or less						
	Repeatability		1 % or less						
	Input Signal		Specified Control Pressure / 5 V DC						
Coil Resistance	Ω [ @ 20°C (68 °F) ]	10							
Input Impedance		Flow Control : 10kΩ Pres. Control : 10kΩ							
Supply Electric Power		24 V DC (21 - 28 V Included Ripple)							
Power Input (Max.)	W	30							
Output Signal	Flow		5 V DC / Max. Flow						
	Pressure		5 V DC / Specified Control Pressure						
Alarm Signal Output (Open Collector)		Voltage : Max. 30 V DC Current : Max. 40 mA							
Ambient Temperature	°C (°F)	0 - 50 (32 - 122) (With Circulated Air)							
Mass	kg (lbs.)	Flange Mtg.	20.7 (45.6)	20.7 (45.6)	32.2 (71)	39.2 (86.4)	64 (141)	76.5 (169)	98 (216)
		Foot Mtg.	22.9 (50.5)	22.9 (50.5)	36.5 (80.5)	43.5 (95.9)	76 (168)	97 (214)	123 (271)

★1. Whenever setting pressure, make sure the full cut-off pressure never exceeds the maximum intermittent pressure.

★2. When operating the pump exceeding the rated pressure, operating conditions are restricted. Refer to page 33 for the details.

★3. Maximum flow differs to shaft speed. The value listed above indicates shaft speed of 1800 r/min. For other shaft speed calculate by the ratio of shaft speed.

Pipe Flange Kits

For Pipe flange, refer to form of pressure compensator type on page 34.

Instructions

Input Signal

The pump is on unload condition when the pump is operated without input signal voltage.

Electric Source

Always turn off electric source whenever the connector for swash plate tilt angle sensor is removed.

Compensation of Pump Maximum Regulated Flow at Frequency

If the same maximum flow is required at 50 Hz or 60 Hz, connect short plug in the amplifier to 60 Hz at the place where supplied frequency is 60 Hz. At this condition, maximum flow comes to the same value at 50 Hz.

If short plug is used at 60 Hz without making the change, maximum flow increased in proportion to frequency.

Painting on Amp. Box and Solenoid

To maintain suitable radiation effect, the amp. box and the solenoid of the control valve should not be painted.

■ Output Flow vs. Input Signal

● A16

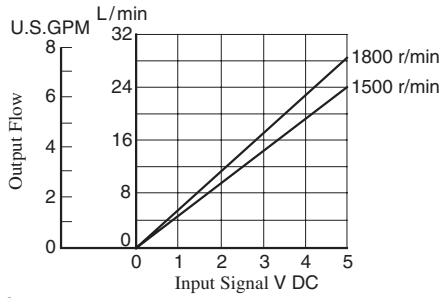

● A56

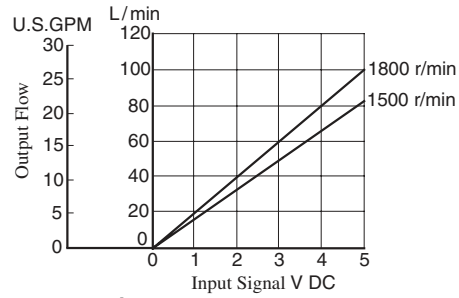

● A22

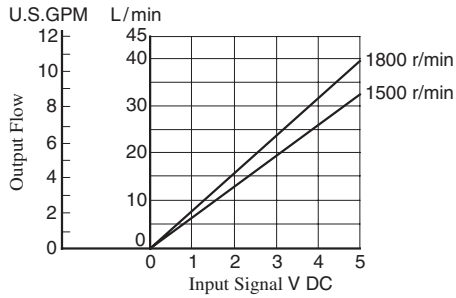

● A70

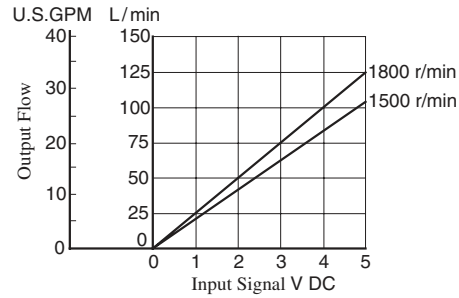

● A37

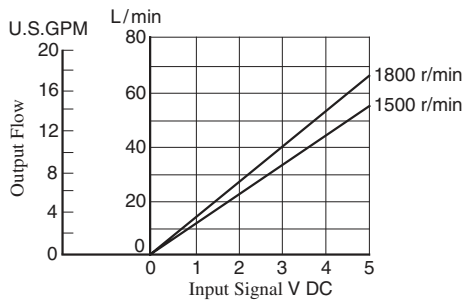

● A90

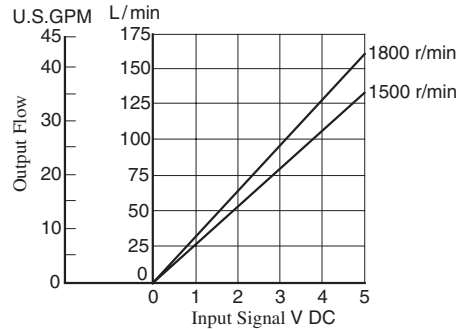

Note: Pump characteristics at 1800 r/min is the same as those at 1500 r/min where frequency is compensated. (Refer to page 87.)

● A145

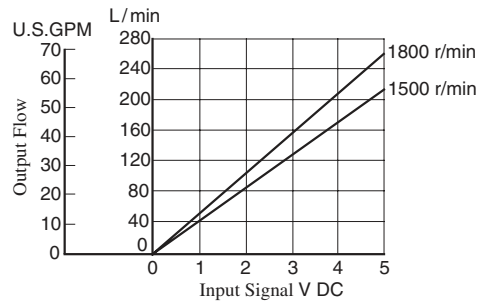

■ Full Cut-off Pres. vs. Input Signal

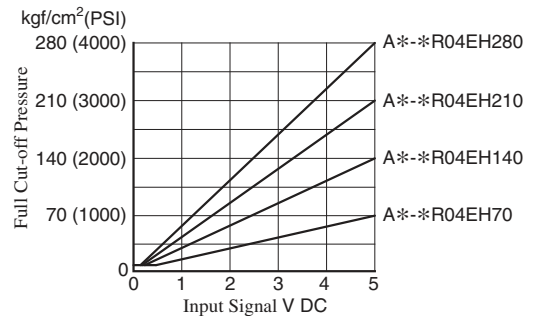
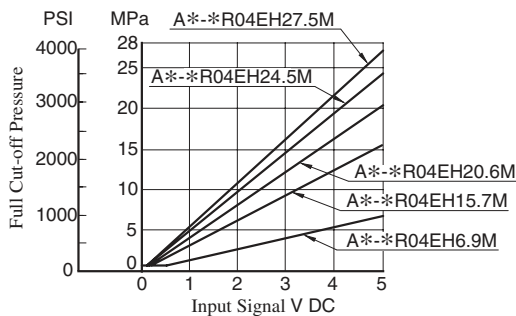

Refer to page 37 to 43 for performance characteristics of pressure compensator type excluding characteristics appeared on this catalogue.

Axial Port Type

Flange Mtg.: A16-FR04EH\*-\*-42/42950  
A22-FR04EH\*-\*-42/42950

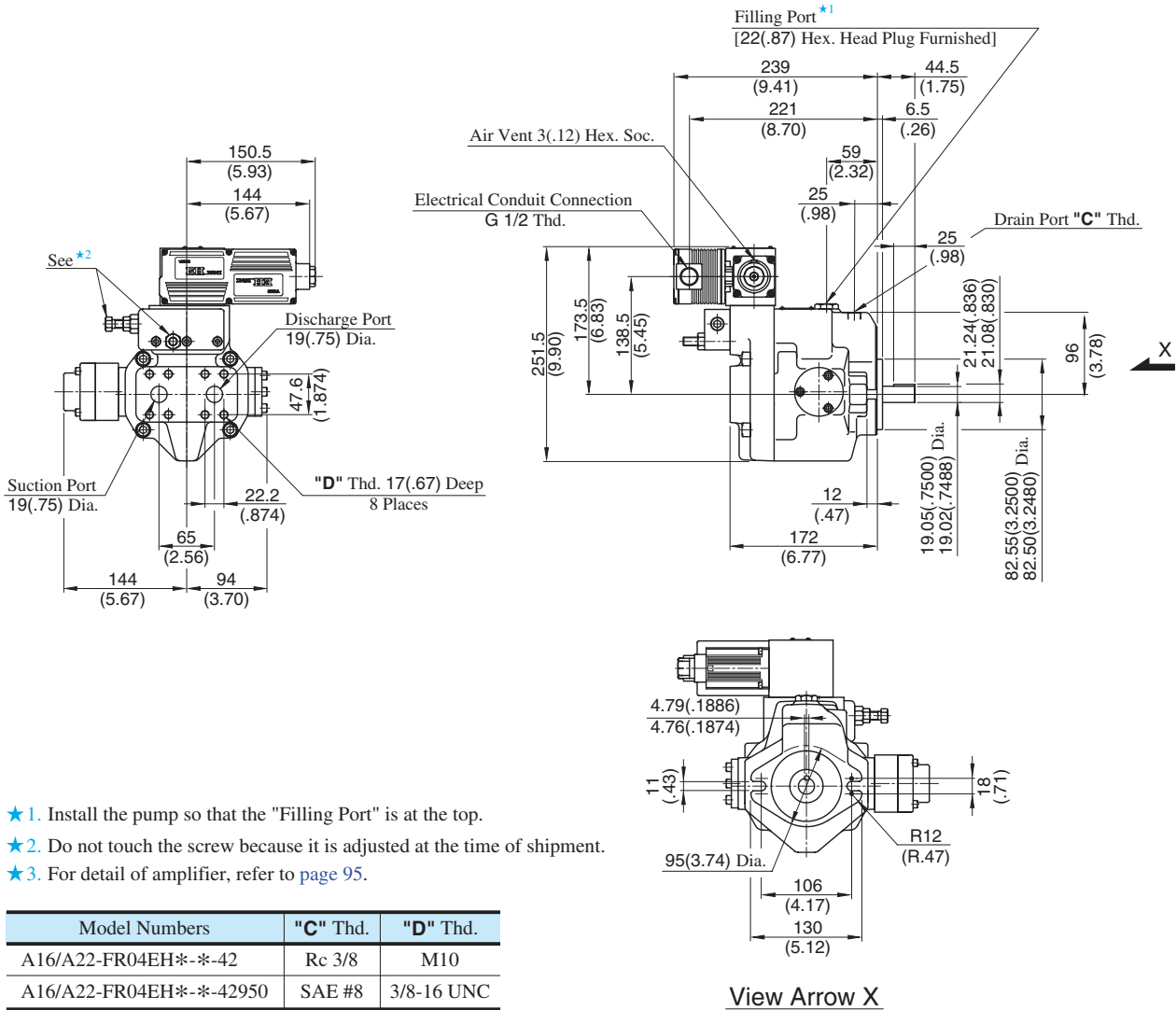

- ★ 1. Install the pump so that the "Filling Port" is at the top.
- ★ 2. Do not touch the screw because it is adjusted at the time of shipment.
- ★ 3. For detail of amplifier, refer to page 95.

Model Numbers	"C" Thd.	"D" Thd.
A16/A22-FR04EH*-*-42	Rc 3/8	M10
A16/A22-FR04EH*-*-42950	SAE #8	3/8-16 UNC

DIMENSIONS IN MILLIMETRES (INCHES)

● Side Port Type

Port mounting dimensions are the same as those of pressure compensator model. Refer to page 45 for port mounting dimensions.

● Foot Mounting Type

Mounting bracket is common to that of pressure compensator model. Refer to page 45 for the dimensions of mounting bracket.

**Axial Port Type**

Flange Mtg.: A37-FR04EH\*-\*-42/42950

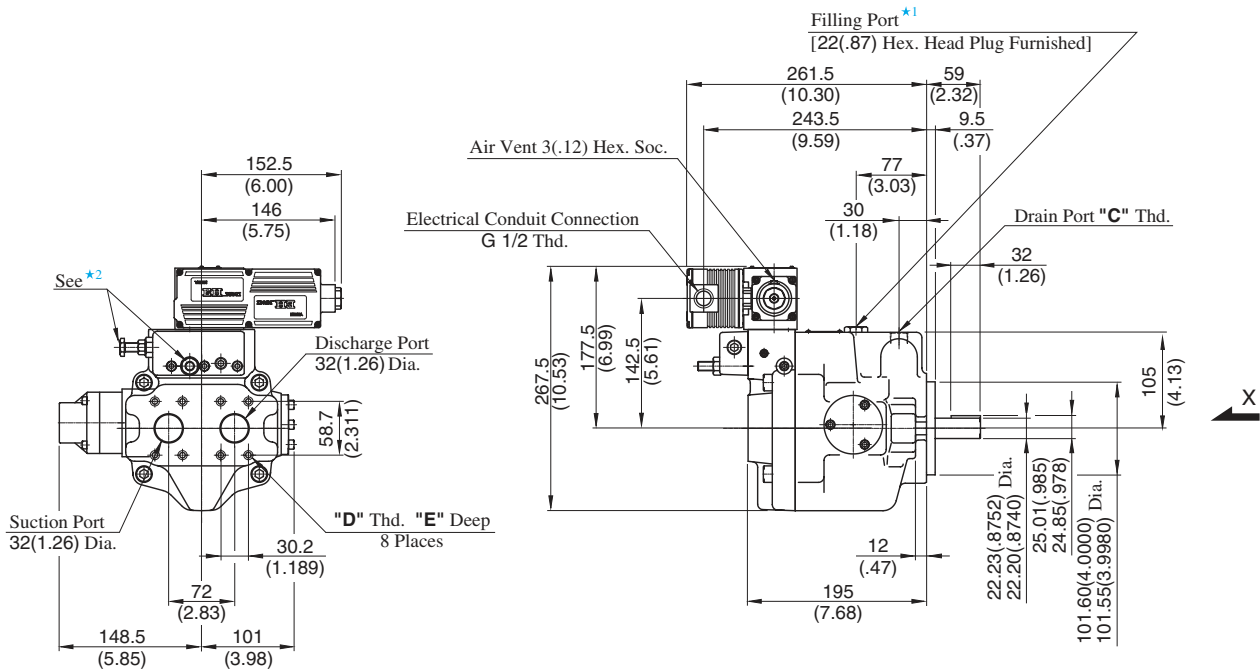

- ★ 1. Install the pump so that the "Filling Port" is at the top.
- ★ 2. Do not touch the screw because it is adjusted at the time of shipment.
- ★ 3. For detail of amplifier, refer to [page 95](#).

Model Numbers	"C" Thd.	"D" Thd.	"E" mm (IN.)
A37-FR04EH*-*-42	Rc 1/2	M10	19 (.75)
A37-FR04EH*-*-42950	SAE #10	7/16-14 UNC	20 (.79)

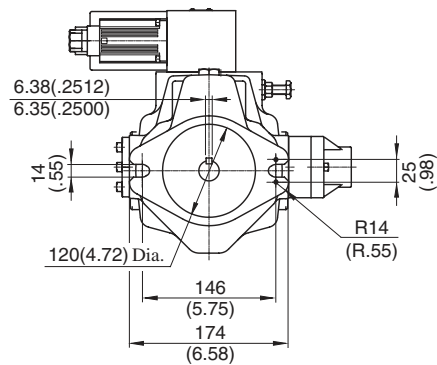

View Arrow X

**DIMENSIONS IN MILLIMETRES (INCHES)**

● **Side Port Type**

Port mounting dimensions are the same as those of pressure compensator model. Refer to [page 46](#) for port mounting dimensions.

● **Foot Mounting Type**

Mounting bracket is common to that of pressure compensator model. Refer to [page 46](#) for the dimensions of mounting bracket.

Axial Port Type

Flange Mtg.: A56-FR04EH\*-\*-42/4290

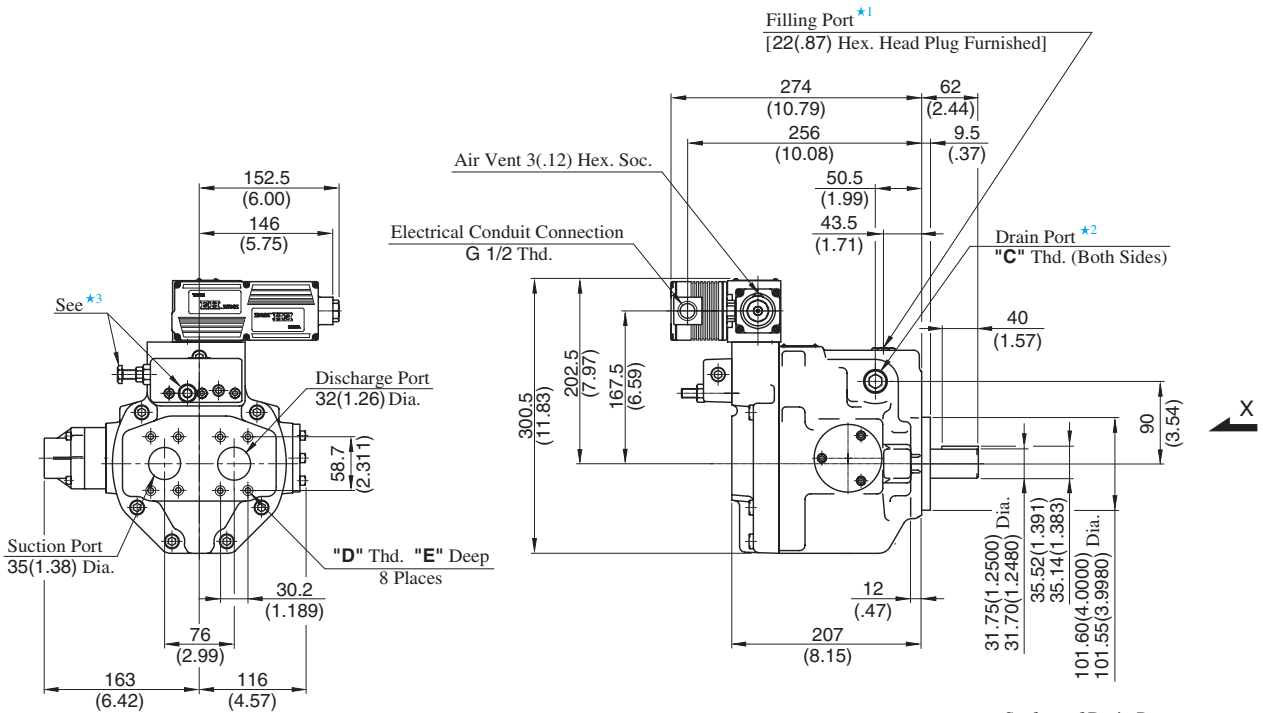

- ★ 1. Install the pump so that the "Filling Port" is at the top.
- ★ 2. Use either port of two drain ports at your option. Keep the remaining port plugged.
- ★ 3. Do not touch the screw because it is adjusted at the time of shipment.
- ★ 4. For detail of amplifier, refer to page 95.

Model Numbers	"C" Thd.	"D" Thd.	"E" mm (IN.)
A56-FR04EH*-*-42	Rc 3/4	M10	19 (.75)
A56-FR04EH*-*-4290	SAE #12	7/16-14 UNC	20 (.79)

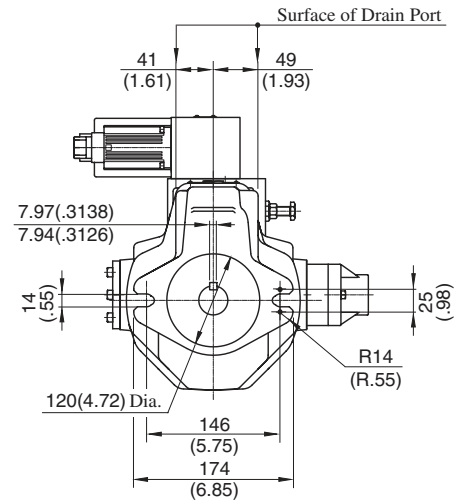

View Arrow X

DIMENSIONS IN MILLIMETRES (INCHES)

● Side Port Type

Port mounting dimensions are the same as those of pressure compensator model. Refer to page 47 for port mounting dimensions.

● Foot Mounting Type

Mounting bracket is common to that of pressure compensator model. Refer to page 47 for the dimensions of mounting bracket.

**Flange Mtg.**

- Amplifier Direction "L" : A70-FR04EH\*LS\*-60/60950

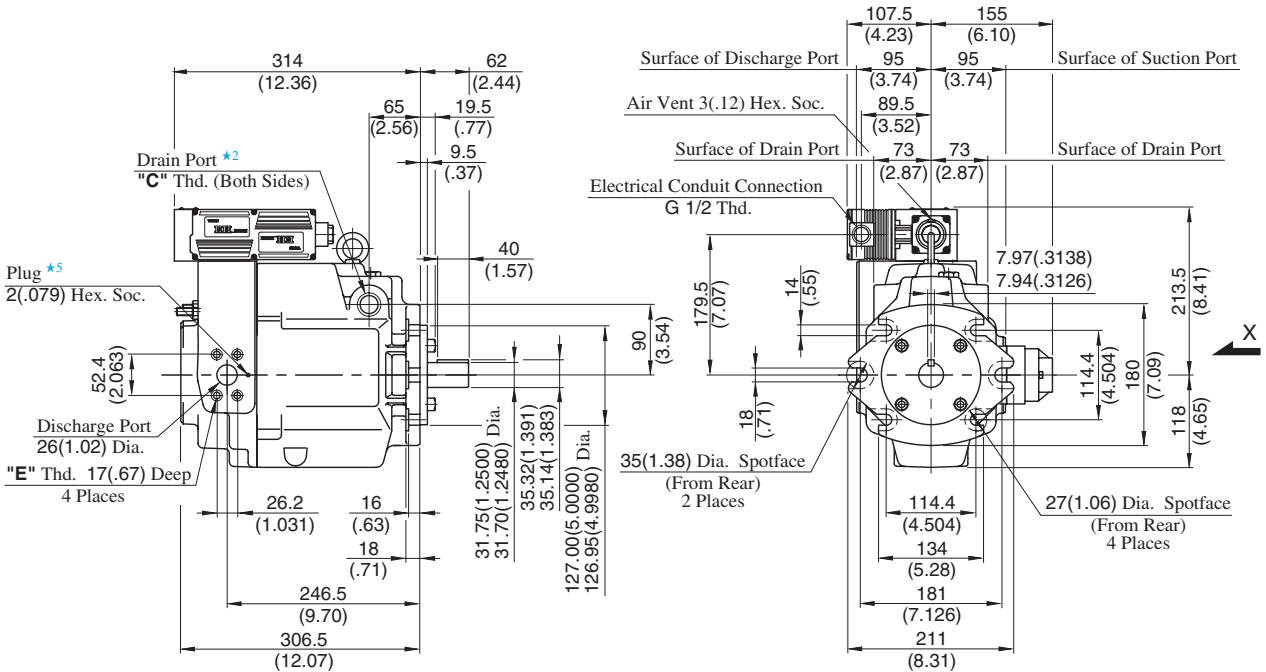

- Amplifier Direction "R" : A70-FR04EH\*RS\*-60/60950

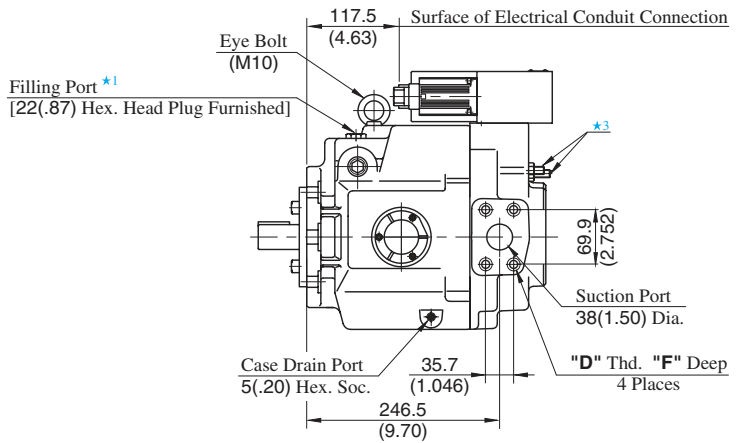
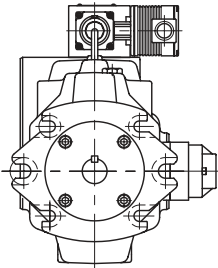

**View Arrow X**

- ★ 1. Install the pump so that the "Filling Port" is at the top.
- ★ 2. Use either port of two drain ports at your option. Keep the remaining port plugged.
- ★ 3. Do not touch the screw because it is adjusted at the time of shipment.
- ★ 4. For detail of amplifier, refer to [page 95](#).
- ★ 5. If you use the special sequence valve, remove the plug.

Model Numbers	"C" Thd.	"D" Thd.	"E" Thd.	Dimensions mm (IN.)
				F
A70-FR04EH**S*-60	Rc 3/4	M12	M10	19 (.75)
A70-FR04EH**S*-60950	SAE #12	1/2-13 UNC	3/8-16 UNC	21 (.83)

**DIMENSIONS IN MILLIMETRES (INCHES)**

● **Foot Mounting Type**

Mounting bracket is common to that of pressure compensator model.  
Refer to [page 48](#) for the dimensions of mounting bracket.



Flange Mtg.

- Amplifier Direction "L" : A90-FR04EH\*LS-\*-60/60950

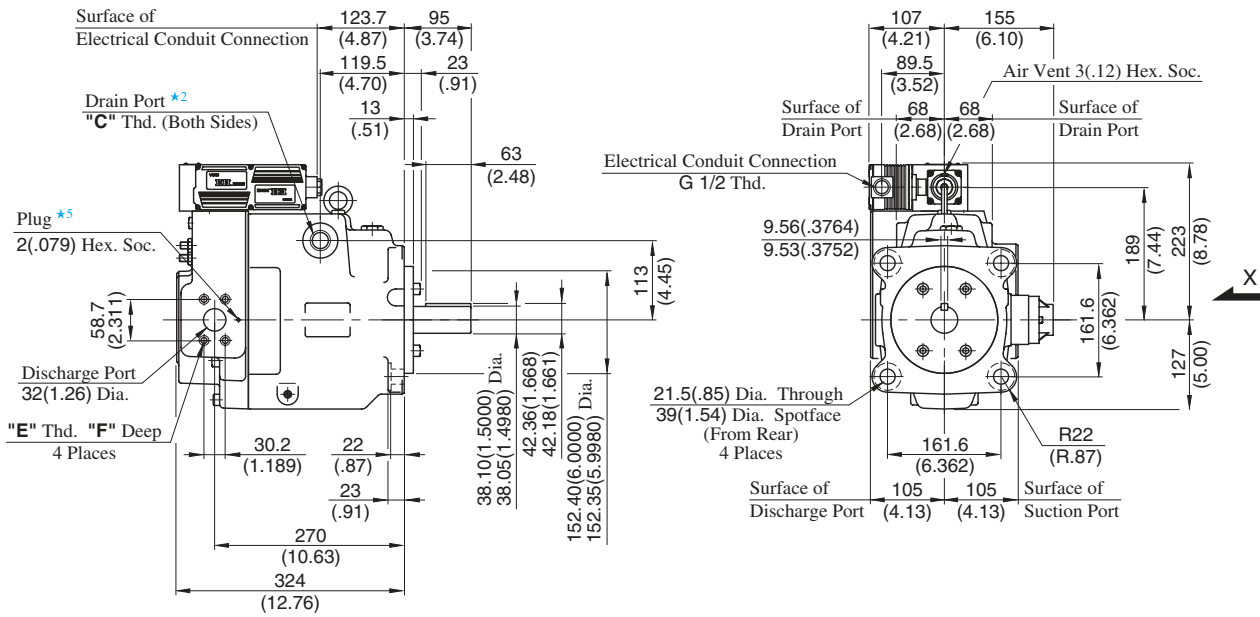

- Amplifier Direction "R" : A90-FR04EH\*RS-\*-60/60950

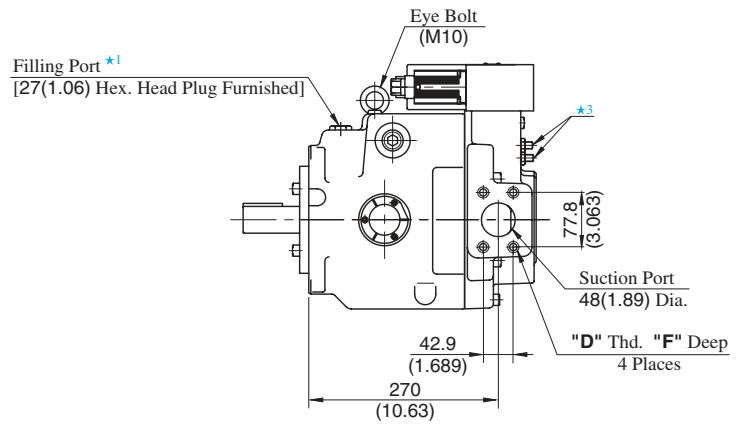
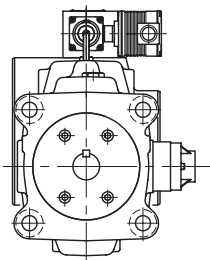

View Arrow X

- ★ 1. Install the pump so that the "Filling Port" is at the top.
- ★ 2. Use either port of two drain ports at your option. Keep the remaining port plugged.
- ★ 3. Do not touch the screw because it is adjusted at the time of shipment.
- ★ 4. For detail of amplifier, refer to page 95.
- ★ 5. If you use the special sequence valve, remove the plug.

Model Numbers	"C" Thd.	"D" Thd.	"E" Thd.	Dimensions mm (IN.)
				F
A90-FR04EH**S-*-60	Rc 3/4	M12	M10	19 (.75)
A90-FR04EH**S-*-60950	SAE #12	1/2-13 UNC	7/16-14 UNC	21 (.83)

DIMENSIONS IN MILLIMETRES (INCHES)

● Foot Mounting Type

Mounting bracket is common to that of pressure compensator model. Refer to page 49 for the dimensions of mounting bracket.

**Flange Mtg.**

- Amplifier Direction "L" : A145-FR04EH\*LS\*-60/60950

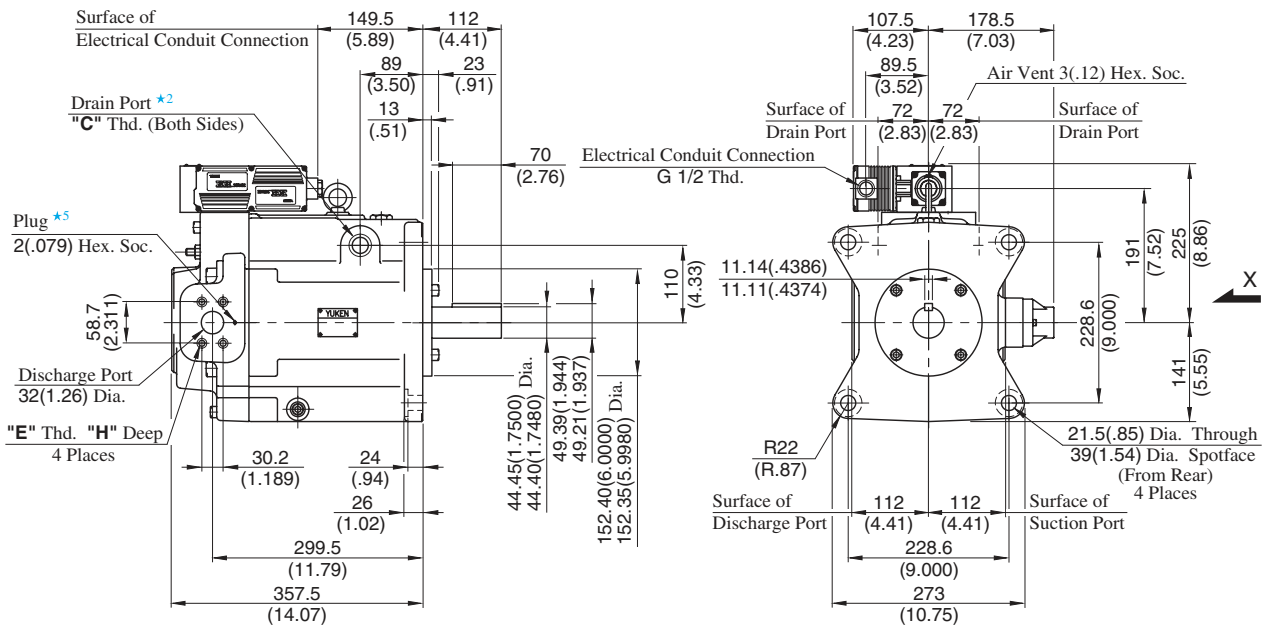

- Amplifier Direction "R" : A145-FR04EH\*RS\*-60/60950

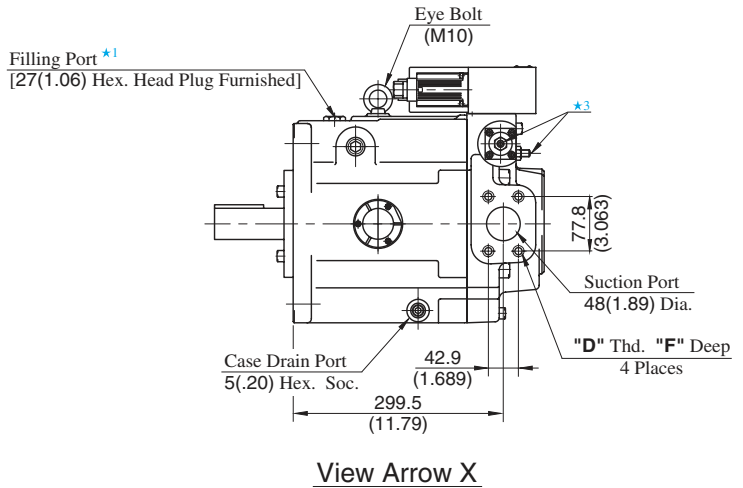
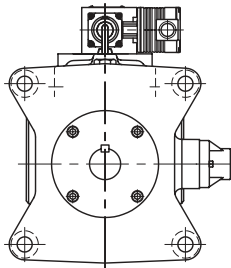

- ★1. Install the pump so that the "Filling Port" is at the top.
- ★2. Use either port of two drain ports at your option. Keep the remaining port plugged.
- ★3. Do not touch the screw because it is adjusted at the time of shipment.
- ★4. For detail of amplifier, refer to page 95.
- ★5. If you use the special sequence valve, remove the plug.

Model Numbers	"C" Thd.	"D" Thd.	"E" Thd.	Dimensions mm (IN.)	
				F	H
A145-FR04EH**S*-60	Rc 3/4	M12	M10	19 (.75)	19 (.75)
A145-FR04EH**S*-60950	SAE #12	1/2-13 UNC	7/16-14 UNC	21 (.83)	20 (.79)

**DIMENSIONS IN MILLIMETRES (INCHES)**

● **Foot Mounting Type**

Mounting bracket is common to that of pressure compensator model. Refer to page 50 for the dimensions of mounting bracket.



- Detail of Amplifier
- Connecting Terminal

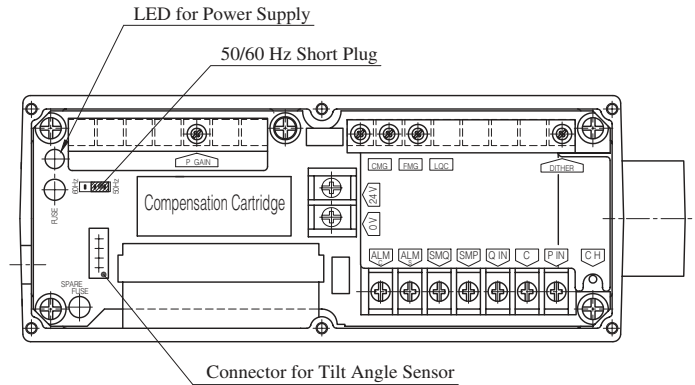

Terminal	Name
P IN	Input Signal, Pressure (+)
C	Input Signal (COM)
Q IN	Input Signal, Flow (+)
SMP	Sensor Monitor Output, Pressure
SMQ	Sensor Monitor Output, Tilt Angle
0 V	Power Supply
24 V	
ALM S	Alarm Output
ALM C	Alarm Output (COM)
CH	Output Current Check (to COM)

- Note 1. For "SENSOR MONITOR" terminal, external instruments should have input impedance of more than 10 kΩ.
2. For "CH" terminal, external instruments should have input impedance of more than 10 kΩ.
3. Volume adjustment of "DITHER", "GAIN", "CMG", "FMG" and "LQC" is made at the time of shipment. Adjustment at the customer is not required.
4. Use shielded cable for "Input" connection. The ground of the shielded cable must be connected to input signal side.

- Circuit Schematic

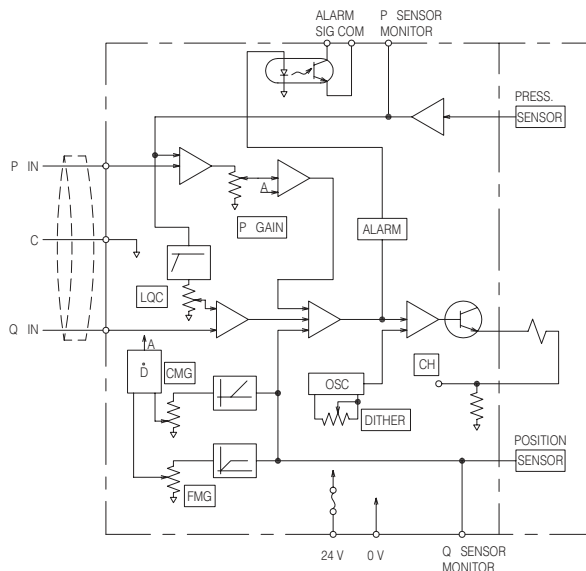

# "A" Series Variable Displacement Piston Pumps – Single Pump, Pilot Pressure Control Type Pressure Compensator

Graphic Symbol

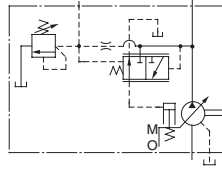

Performance Characteristics

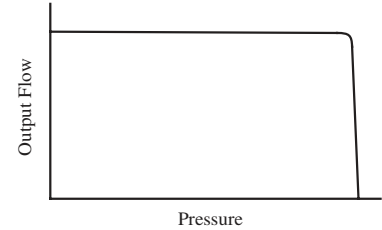

## Specifications

Model Numbers	Geometric Displacement cm <sup>3</sup> /rev (cu. in. /rev)	Minimum Adj. Flow cm <sup>3</sup> /rev (cu. in. /rev)	Operating Pressure MPa (PSI)		Minimum Adj. Pres. MPa (PSI)	Shaft Speed Range r/min		Approx. Mass kg (lbs.)	
			Rated <sup>★2</sup>	Intermittent <sup>★1</sup>		Max.	Min.	Flange Mtg.	Foot Mtg.
A10-FR07-12*	10.0 (.610)	2 (.122)	16 (2320)	21 (3050)	2.0 (290)	1800	600	8.5 (18.7)	10.7 (23.6)
A16-*-R-07-*-K-32*	15.8 (.964)	4 (.244)	16 (2320)	21 (3050)	1.2 (175)	1800	600	21 (46.3)	23.2 (51.2)
A22-*-R-07-*-K-32*	22.2 (1.355)	6 (.366)	16 (2320)	16 (2320)	1.2 (175)	1800	600	21 (46.3)	23.2 (51.2)
A37-*-R-07-*-K-32*	36.9 (2.25)	10 (.610)	16 (2320)	21 (3050)	1.2 (175)	1800	600	29 (63.9)	33.3 (73.4)
A56-*-R-07-*-K-32*	56.2 (3.43)	12 (.732)	16 (2320)	21 (3050)	1.2 (175)	1800	600	36 (79.4)	40.3 (88.9)
A70-*R07S-60*	70.0 (4.27)	30 (1.83)	25 (3630)	25 (3630)	2 (290)	1800	600	60.3 (133)	72.3 (159)
A90-*R07S-60*	91.0 (5.55)	56 (3.42)	25 (3630)	25 (3630)	2 (290)	1800	600	77.5 (171)	98 (216)
A145-*R07S-60*	145 (8.85)	83 (5.06)	25 (3630)	25 (3630)	2 (290)	1800	600	94 (207)	119 (262)

- ★1. Whenever setting pressure, make sure the full cut-off pressure never exceeds the maximum intermittent pressure.
- ★2. When operating the pump exceeding the rated pressure, operating conditions are restricted. Refer to [page 33](#) for the details.



Model Number Designation

A16	-F	-R	-07	-S	-K	-32	*
Series Number	Mounting	Direction of Rotation	Control Type	Port Position	Shaft Extension	Design Number	Design Std.
<b>A16</b> (15.8 cm <sup>3</sup> /rev)	<b>F:</b> Flange Mtg.	(Viewed from) Shaft End	<b>07:</b> Pilot Pressure Control Type Pressure Compensator	<b>None:</b> Axial Port	<b>K:</b> Keyed Shaft	<b>32</b>	Refer to <sup>*3</sup>
<b>A22</b> (22.2 cm <sup>3</sup> /rev)						<b>32</b>	
<b>A37</b> (36.9 cm <sup>3</sup> /rev)	<b>L:</b> Foot Mtg.	<b>R:</b> Clockwise <sup>*1</sup> (Normal)				<b>32</b>	
<b>A56</b> (56.2 cm <sup>3</sup> /rev)						<b>32</b>	

A70	-F	R	07	S	-60	*
Series Number	Mounting	Direction of Rotation	Control Type	Port Position	Design Number	Design Std.
<b>A10</b> (10.0 cm <sup>3</sup> /rev)	<b>F:</b> Flange Mtg. <sup>*2</sup>	(Viewed from) Shaft End	<b>07:</b> Pilot Pressure Control Type Pressure Compensator	—	<b>12</b>	Refer to <sup>*3</sup>
<b>A70</b> (70.0 cm <sup>3</sup> /rev)	<b>F:</b> Flange Mtg.				<b>R:</b> Clockwise <sup>*1</sup> (Normal)	
<b>A90</b> (91.0 cm <sup>3</sup> /rev)		<b>60</b>				
<b>A145</b> (145 cm <sup>3</sup> /rev)		<b>L:</b> Foot Mtg.		<b>60</b>		

★1. Available to supply pump with anti-clockwise rotation. Consult Yuken for details.

★2. When A10 pump is used as the foot Mtg., order the Mtg. Bracket kit shown below separately. Refer to page 24 for dimensions of the Mtg. bracket.

Mtg. Bracket Kit Numbers	Approx. Mass kg (lbs.)
LP-1A-10	2.2 (4.9)

Note: The mounting bracket kit consists of a mounting bracket, 2 hex. bolts and 2 plain washer.

★3. Design Standards: None ..... Japanese Standard "JIS"  
80 ..... European Design Standard  
950 ..... N. American Design Standard

Performance Characteristics

For performance characteristics, refer to models of pressure compensator type on page 36 to 43.

Pipe Flange Kit

For pipe flange, refer to form of pressure compensator type on page 34.

Flange Mtg.

**DIMENSIONS IN MILLIMETRES (INCHES)**

● Japanese Standard "JIS" : A10-FR07-12

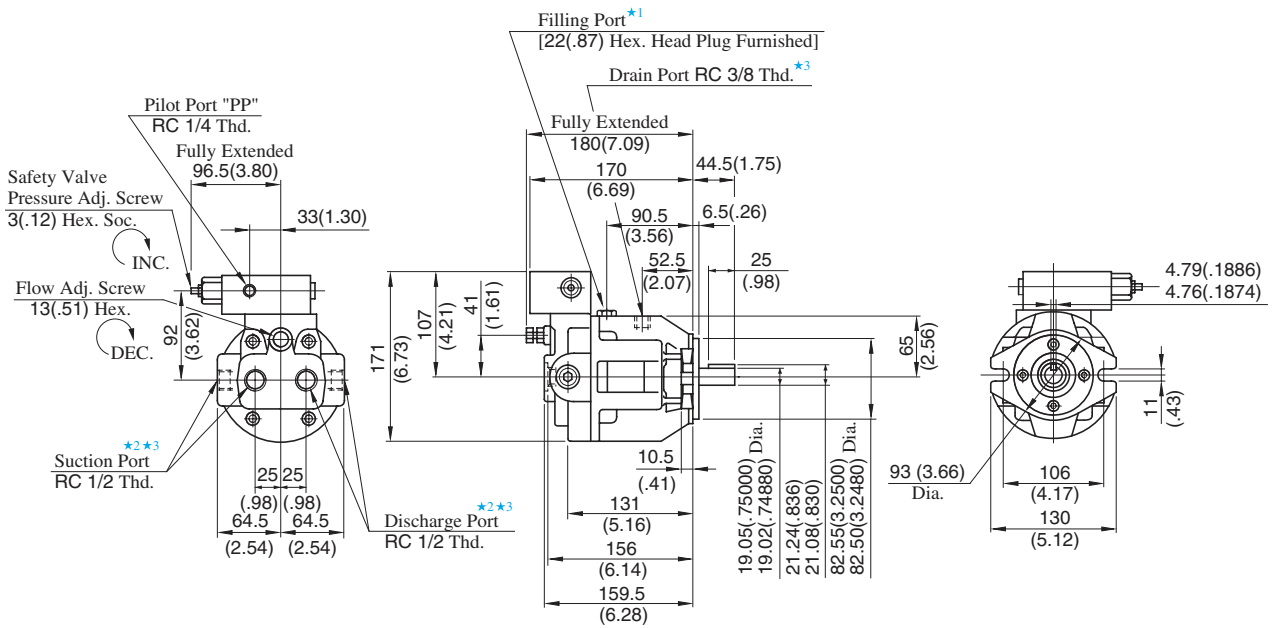

- European Design Standard : A10-FR07-1280
- N. American Design Standard : A10-FR07-12950

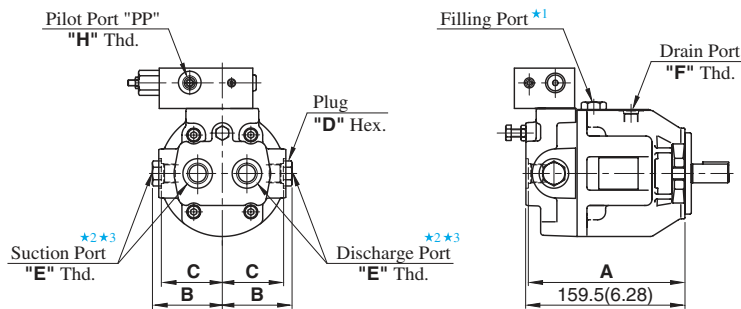

Model Numbers	Dimensions mm (IN.)				Thread Size		
	A	B	C	D	E	F	h
A10-FR07-1280	159 (6.26)	72 (2.83)	64 (2.52)	22 (.87)	1/2 BSP. F	3/8 BSP. F	1/4 BSP. Tr
A10-FR07-12950	157 (6.18)	71 (2.80)	62 (2.44)	27 (1.06)	SAE #8	SAE #6	SAE #4

● For other dimensions, refer to Japanese Standard "JIS".

- ★1. Install the pump so that the "Filling Port" is at the top.
- ★2. Use either port of two suction and discharge ports at your option. Keep the remaining ports plugged.
- ★3. As the tightening torques of suction, discharge and drain port fittings, conform to the below.

Model Numbers	Tightening Torque Nm (IN. lbs.)	
	Suction Port & Discharge Port	Drain Port
A70-FR07-12	65-75 (575-664)	40-50 (354-443)
A70-FR07-1280	56-62 (496-549)	33-36 (292-319)
A70-FR07-12950	47-51 (416-451)	40-50 (354-443)

Axial Port Type

Flange Mtg. : A16-F-R-07-K-32/3280/32950  
A22-F-R-07-K-32/3280/32950

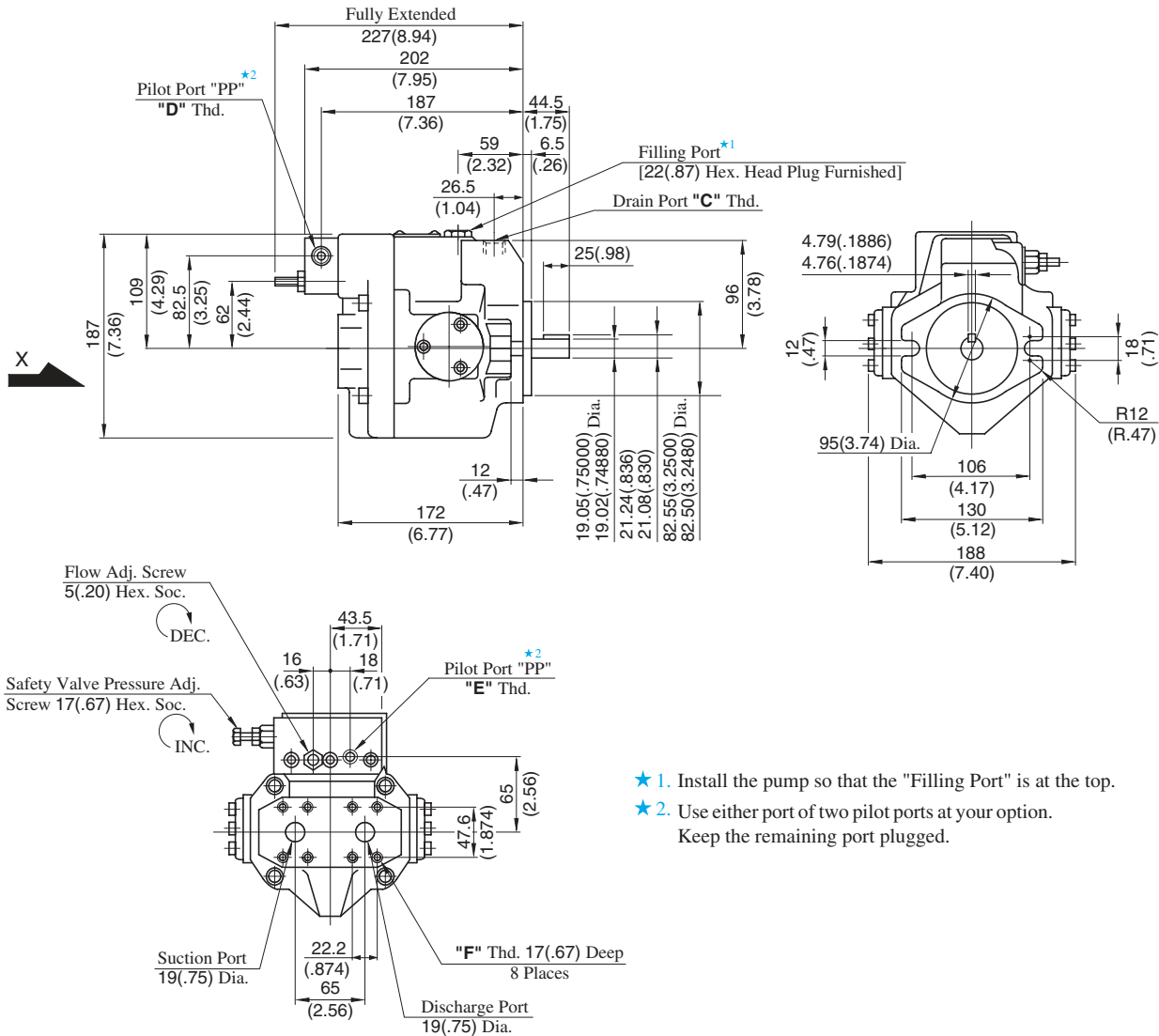

View Arrow X

Model Numbers	"C" Thd.	"D" Thd.	"E" Thd.	"F" Thd.
A16/A22-F-R-07-K-32	Rc 3/8	Rc 3/8	Rc 1/4	M10
A16/A22-F-R-07-K-3280	3/8 BSP. F	3/8 BSP. F	1/4 BSP. Tr	
A16/A22-F-R-07-K-32950	SAE #8	SAE #6	SAE #4	3/8-16 UNC

DIMENSIONS IN MILLIMETRES (INCHES)

● Axial Port Type

Port mounting dimensions are the same as those of pressure compensator model. Refer to page 45 for port mounting dimensions.

● Foot Mounting Type

Mounting bracket is common to that of pressure compensator model. Refer to page 45 for the dimensions of mounting bracket.

**Side Port Type**

Flange Mtg. : A37-F-R-07-S-K-32/3280/32950

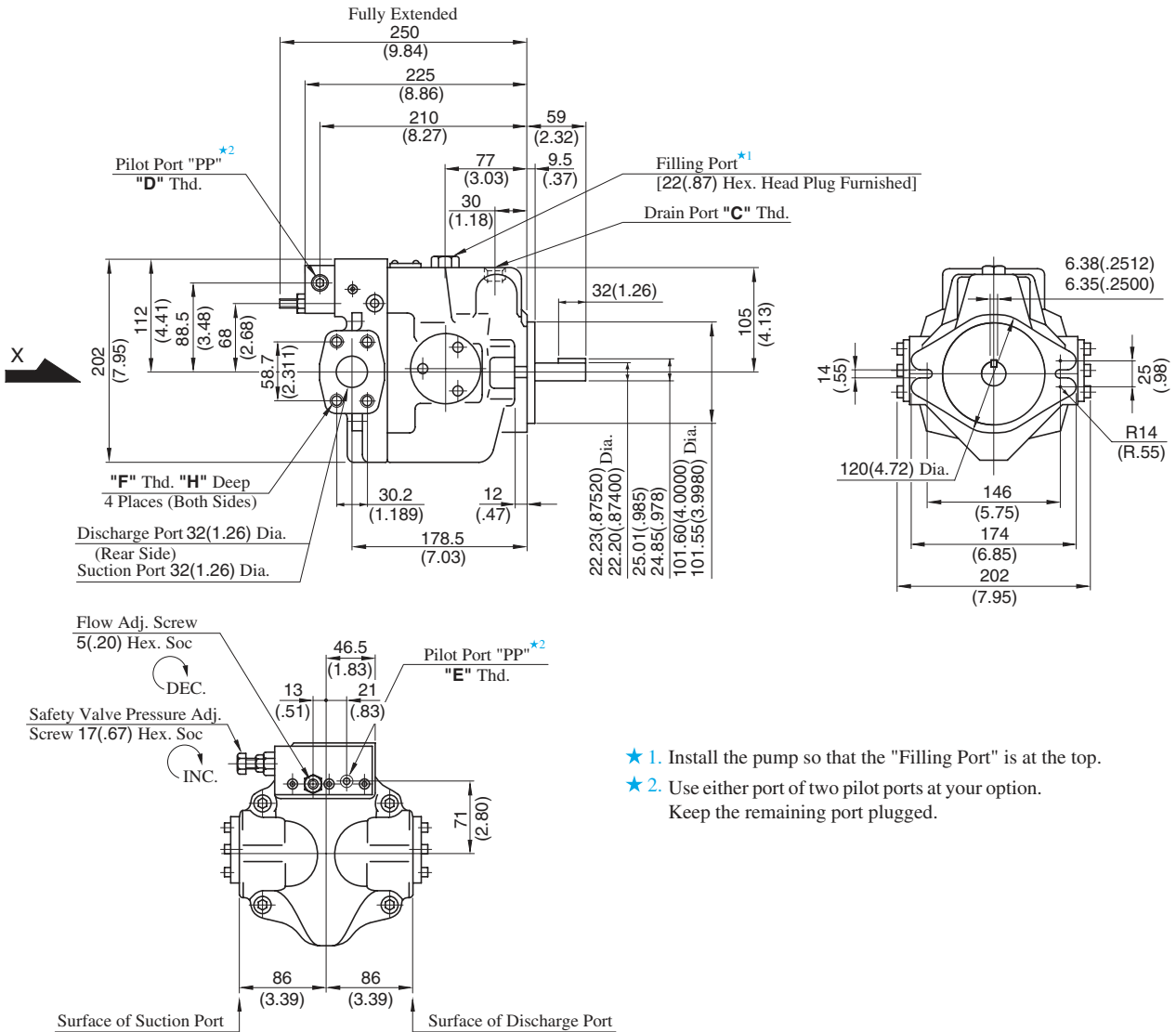

- ★ 1. Install the pump so that the "Filling Port" is at the top.
- ★ 2. Use either port of two pilot ports at your option. Keep the remaining port plugged.

**View Arrow X**

Model Numbers	"C" Thd.	"D" Thd.	"E" Thd.	"F" Thd.	"H" mm (IN.)
A37-F-R-07-S-K-32	Rc 1/2	Rc 3/8	Rc 1/4	M10	19 (.75)
A37-F-R-07-S-K-3280	1/2 BSP.F	3/8 BSP.F	1/4 BSP. Tr		
A37-F-R-07-S-K-32950	SAE #10	SAE #6	SAE #4	7/16-14 UNC	20 (.79)

**DIMENSIONS IN MILLIMETRES (INCHES)**

**● Axial Port Type**

Port mounting dimensions are the same as those of pressure compensator model. Refer to page 46 for port mounting dimensions.

**● Foot Mounting Type**

Mounting bracket is common to that of pressure compensator model. Refer to page 46 for the dimensions of mounting bracket.



Side Port Type

Flange Mtg. : A56-F-R-07-S-K-32/3280/32950

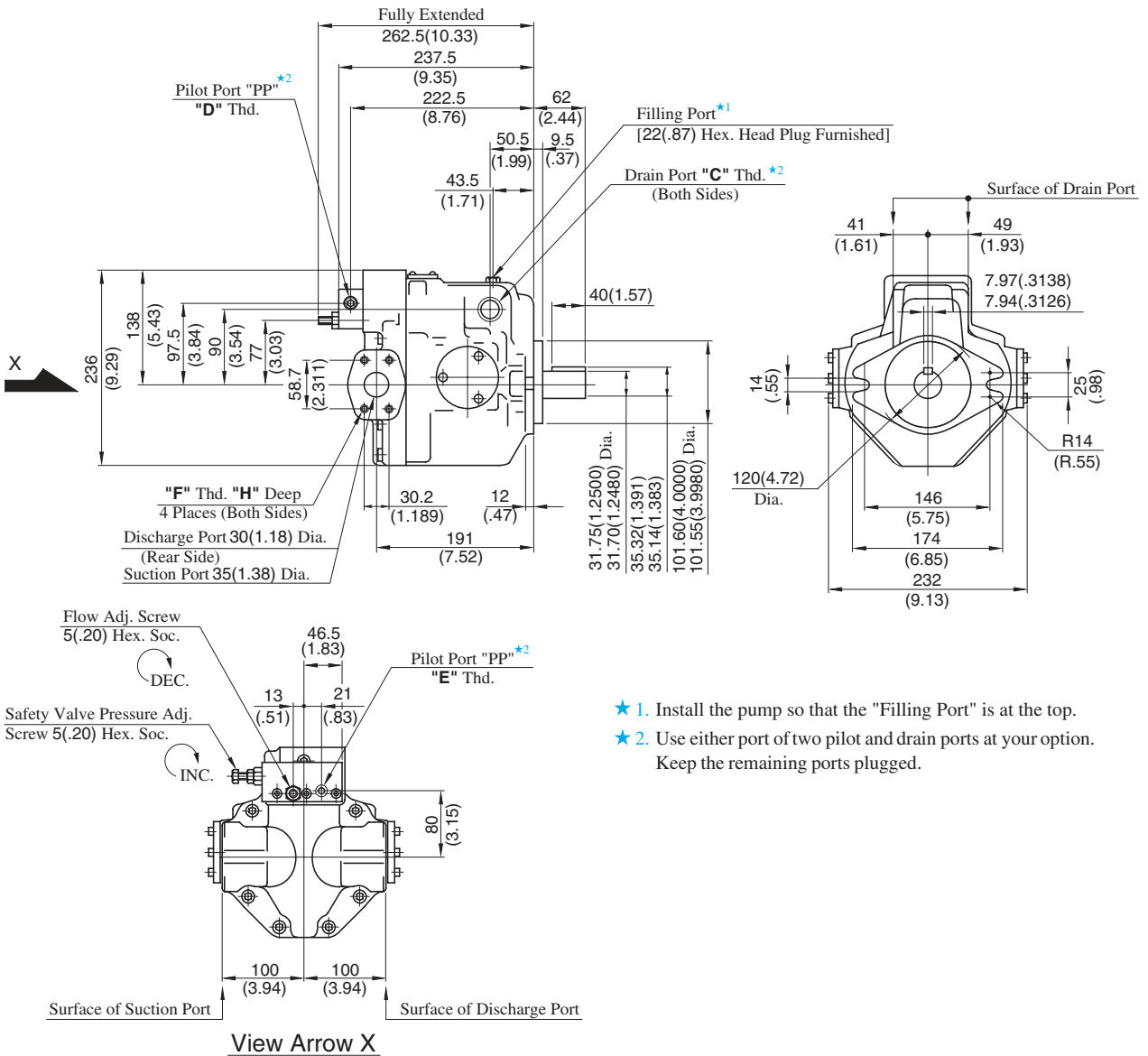

- \* 1. Install the pump so that the "Filling Port" is at the top.
- \* 2. Use either port of two pilot and drain ports at your option. Keep the remaining ports plugged.

Model Numbers	"C" Thd.	"D" Thd.	"E" Thd.	"F" Thd.	"H" mm (IN.)
A56-F-R-07-S-K-32	Rc 3/4	Rc 3/8	Rc 1/4	M10	19 (.75)
A56-F-R-07-S-K-3280	3/4 BSP.F	3/8 BSP.F	1/4 BSP. Tr		
A56-F-R-07-S-K-32950	SAE #12	SAE #6	SAE #4	7/16-14 UNC	20 (.79)

DIMENSIONS IN MILLIMETRES (INCHES)

● Axial Port Type

Port mounting dimensions are the same as those of pressure compensator model. Refer to page 47 for port mounting dimensions.

● Foot Mounting Type

Mounting bracket is common to that of pressure compensator model. Refer to page 47 for the dimensions of mounting bracket.

Flange Mtg. : A70-FR07S-60/6080/60950

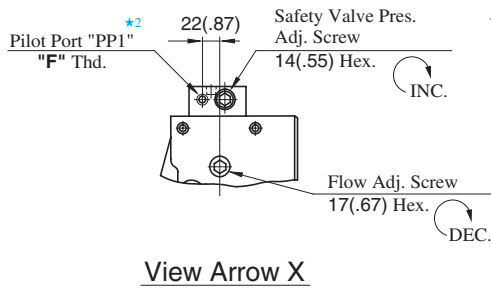
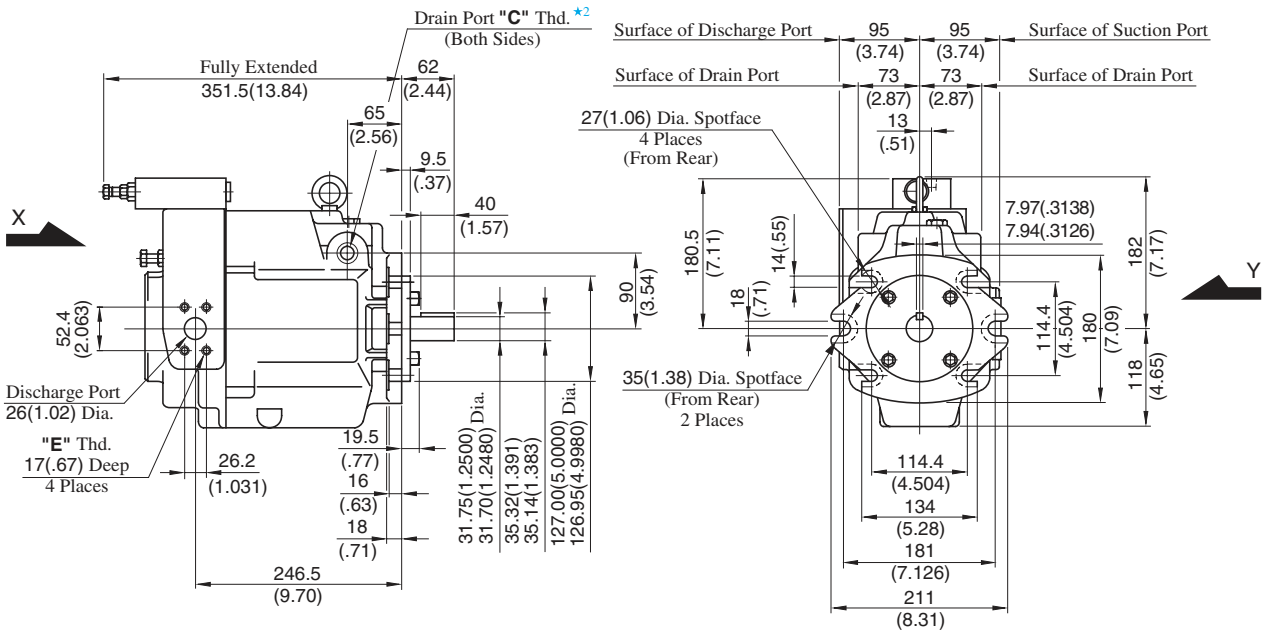

View Arrow X

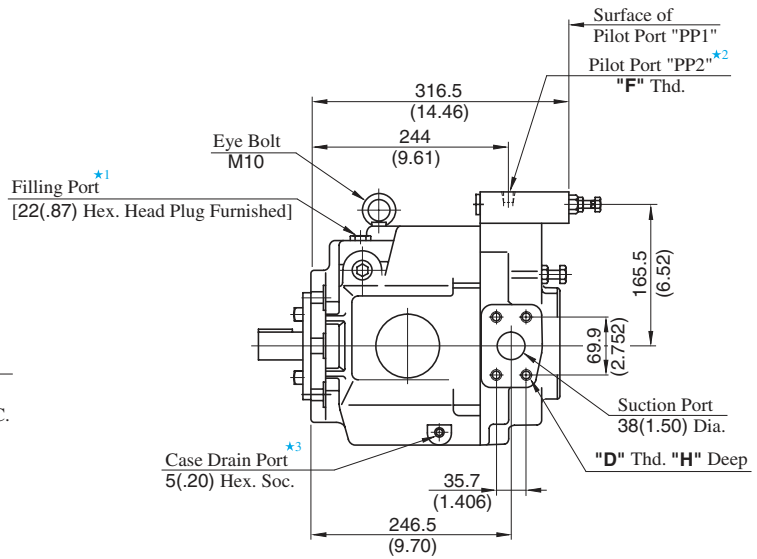

View Arrow Y

- ★ 1. Install the pump so that the "Filling Port" is at the top.
- ★ 2. Use either port of two pilot and drain ports at your option. Keep the remaining ports plugged.
- ★ 3. Case drain port is available for use when draining hydraulic fluid from pump casing.

Model Numbers	"C" Thd.	"D" Thd.	"E" Thd.	"F" Thd.	"H" mm (IN.)
A70-FR07S-60	Rc 3/4	M12	M10	Rc 1/4	19 (.75)
A70-FR07S-6080	3/4 BSP.F			1/4 BSP. Tr	
A70-FR07S-60950	SAE #12	1/2-13 UNC	3/8-16 UNC	SAE #4	21 (.83)

DIMENSIONS IN MILLIMETRES (INCHES)

● **Foot Mounting Type**

Mounting bracket is common to that of pressure compensator model. Refer to page 48 for the dimensions of mounting bracket.

Flange Mtg. : A90-FR07S-60/6080/60950

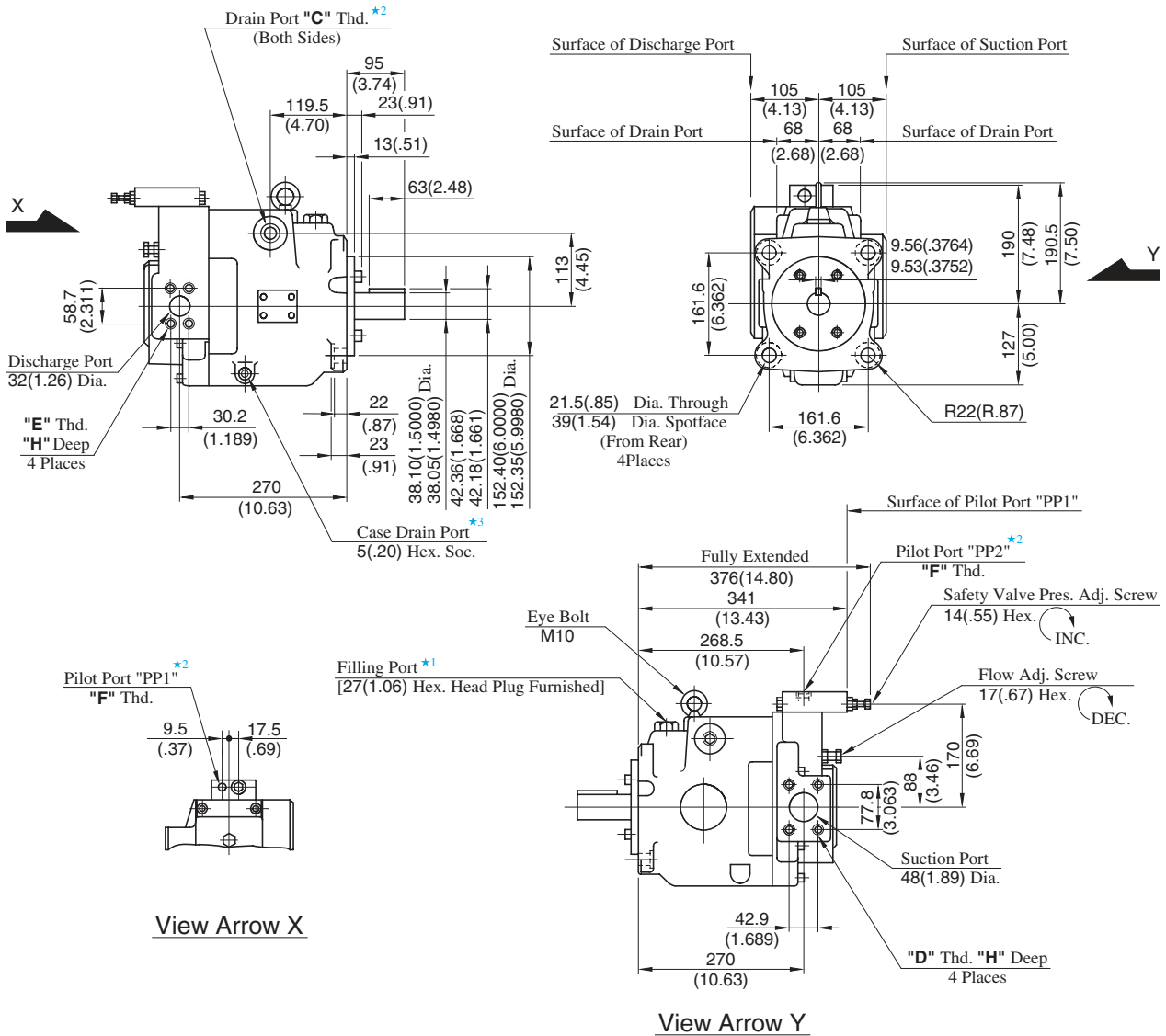

- ★ 1. Install the pump so that the "Filling Port" is at the top.
- ★ 2. Use either port of two pilot and drain ports at your option. Keep the remaining ports plugged.
- ★ 3. Case drain port is available for use when draining hydraulic fluid from pump casing.

Model Numbers	"C" Thd.	"D" Thd.	"E" Thd.	"F" Thd.	H mm (IN.)
A90-FR07S-60	Rc 3/4	M12	M10	Rc 1/4	19 (.75)
A90-FR07S-6080	3/4 BSP.F			1/4 BSP. Tr	
A90-FR07S-60950	SAE #12	1/2-13 UNC	7/16-14 UNC	SAE #4	21 (.83)

DIMENSIONS IN MILLIMETRES (INCHES)

● **Foot Mounting Type**

Mounting bracket is common to that of pressure compensator model. Refer to page 49 for the dimensions of mounting bracket.

Flange Mtg. : A145-FR07S-60/6080/60950

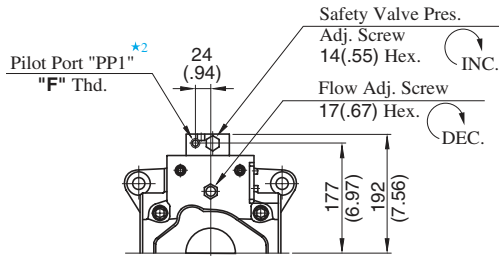
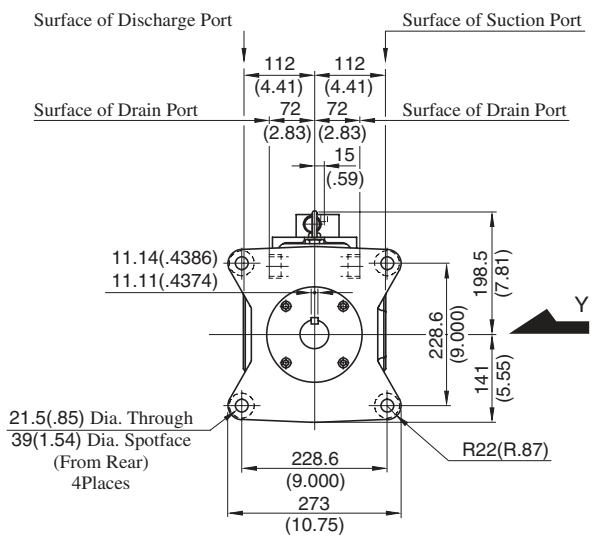
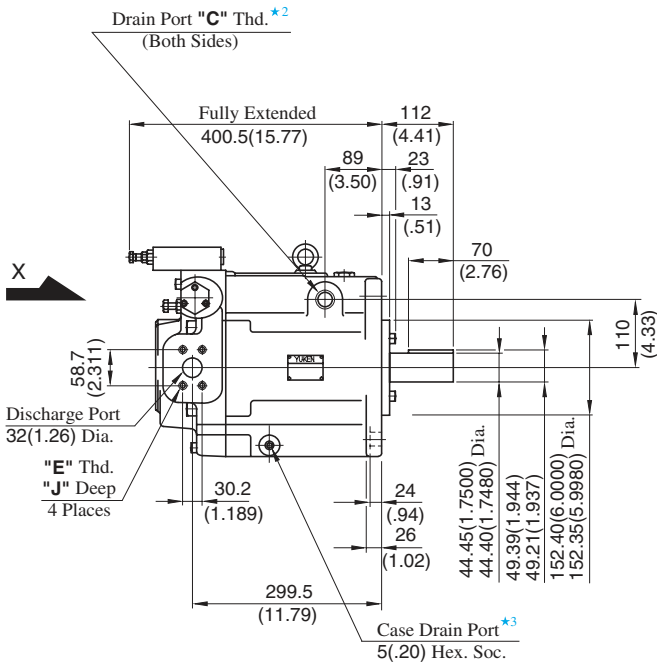

View Arrow X

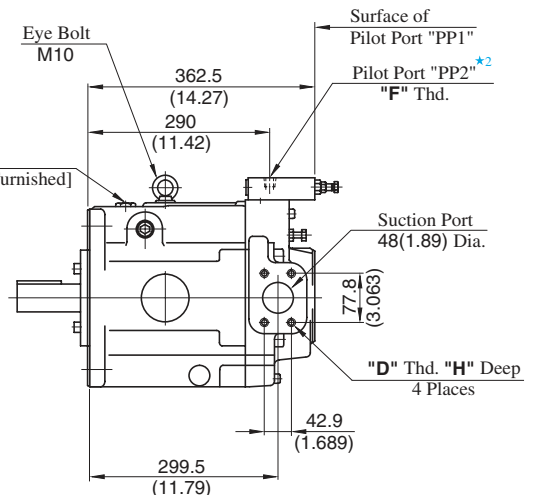

View Arrow Y

- ★ 1. Install the pump so that the "Filling Port" is at the top.
- ★ 2. Use either port of two pilot and drain ports at your option. Keep the remaining ports plugged.
- ★ 3. Case drain port is available for use when draining hydraulic fluid from pump casing.

Model Numbers	"C" Thd.	"D" Thd.	"E" Thd.	"F" Thd.	H mm (IN.)	J mm (IN.)
A145-FR07S-60	Rc 3/4	M12	M10	Rc 1/4	19 (.75)	19 (.75)
A145-FR07S-6080	3/4 BSP.F			1/4 BSP. Tr		
A145-FR07S-60950	SAE #12	1/2-13 UNC	7/16-14 UNC	SAE #4	21 (.83)	20 (.79)

DIMENSIONS IN MILLIMETRES (INCHES)

● **Foot Mounting Type**

Mounting bracket is common to that of pressure compensator model. Refer to page 50 for the dimensions of mounting bracket.

# "A" Series Variable Displacement Piston Pumps – Single Pump, Constant Power Control Type

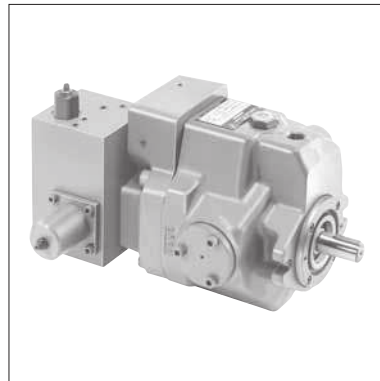

## Performance Characteristics

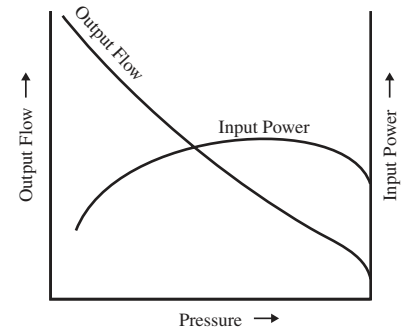

## Graphic Symbols

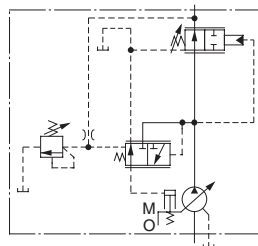

A16

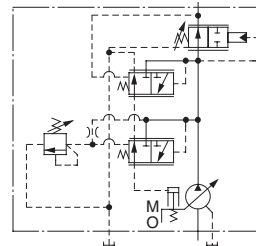

A37/A56

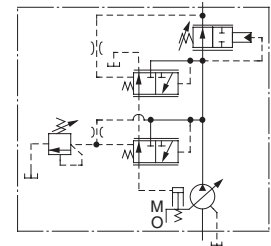

A70/A145

## Specifications

Model Numbers	Geometric Displacement cm <sup>3</sup> /rev (cu. in. /rev)	Minimum Adj. Flow cm <sup>3</sup> /rev (cu. in. /rev)	Operating Pres. MPa (PSI)	Shaft Speed Range r/min		Approx. Mass kg (lbs.)	
			Max.	Max.	Min.	Flange Mtg.	Foot Mtg.
A16-*-R-09-*-K-32*	15.8 (.964)	—	21 (3050) <sup>★1</sup>	1800	600	29.0 (63.9)	31.2 (68.8)
A37-*-R-09-*-K-32*	36.9 (2.25)	—	21 (3050) <sup>★1</sup>	1800	600	37.0 (81.6)	41.3 (91.1)
A56-*-R-09-*-K-32*	56.2 (3.43)	—	21 (3050) <sup>★1</sup>	1800	600	44.0 (97.0)	48.3 (107)
A70-*R09*S-60*	70.0 (4.27)	30 (.295)	25 (3630)	1800	600	72.8 (161)	84.8 (187)
A145-*R09*S-60*	145 (8.85)	83 (5.06)	25 (3630)	1800	600	110 (243)	135 (298)

★1. Maximum Operating Pressure of A16/A37/A56 varies according to Input Power Setting. See Model Number Designation for details.

★2. Minimum Adjustment Flow of A70/A145 is absolutely minimum flow that can be adjusted with Flow Adjustment Screw.

A90 type pump (91 cm<sup>3</sup>/rev) is available. Ask Yuken for Details.

**Model Number Designation**

**● A16/A37/A56**

A16	-F	-R	-09	-A		-16M	-K	-32	*
Series Number	Mounting	Direction of Rotation	Control Type	Input Power Setting		Specify Control Pres.*2	Shaft Extension	Design Number	Design Std.
<b>A16</b> (15.8 cm <sup>3</sup> /rev)	<b>F:</b> Flange Mtg.	(Viewed from Shaft End)	<b>09:</b> Constant Power Control Type	<b>A:</b> 3.7 kW (5 HP)	<b>E:</b> 2.2 kW (3 HP)	<b>7M:</b> 7 MPa (1020 PSI)	<b>K:</b> Keyed Shaft	<b>32</b>	Refer to ★3
<b>B:</b> 5.5 kW (7.5 HP)				<b>F:</b> 1.5 kW (2 HP)	<b>10.5M:</b> 10.5 MPa (1520 PSI)				
<b>A:</b> 3.7 kW (5 HP)				<b>C:</b> 7.5 kW (10 HP)					
<b>A37</b> (36.9 cm <sup>3</sup> /rev)	<b>L:</b> Foot Mtg.	<b>R:</b> Clockwise*1 (Normal)	<b>09:</b> Constant Power Control Type	<b>B:</b> 5.5 kW (7.5 HP)	<b>D:</b> 11 kW (15 HP)	<b>14M:</b> 14 MPa (2030 PSI)	<b>K:</b> Keyed Shaft	<b>32</b>	Refer to ★3
<b>A:</b> 3.7 kW (5 HP)				<b>E:</b> 15 kW (20 HP)	<b>16M:</b> 16 MPa (2320 PSI)				
<b>B:</b> 5.5 kW (7.5 HP)				<b>F:</b> 18.5 kW (25 HP)					
<b>A56</b> (56.2 cm <sup>3</sup> /rev)	<b>L:</b> Foot Mtg.	<b>R:</b> Clockwise*1 (Normal)	<b>09:</b> Constant Power Control Type	<b>C:</b> 7.5 kW (10 HP)	<b>G:</b> 22 kW (30 HP)	<b>17.5M:</b> 17.5 MPa (2540 PSI)	<b>K:</b> Keyed Shaft	<b>32</b>	Refer to ★3
<b>D:</b> 11 kW (15 HP)				<b>H:</b> 75 kW (100 HP)	<b>21M:</b> 21 MPa (3050 PSI)				

**● A70/A145**

A70	-F	R	09	A		S	-60	*
Series Number	Mounting	Direction of Rotation	Control Type	Input Power Setting		Direction of Port	Design Number	Design Std.
<b>A70</b> (70 cm <sup>3</sup> /rev)	<b>F:</b> Flange Mtg.	(Viewed from Shaft End)	<b>09:</b> Constant Power Control Type	<b>A:</b> 15 kW (20 HP)	<b>E:</b> 22 kW (30 HP)	<b>S:</b> Side Port	<b>60</b>	Refer to ★3
<b>B:</b> 18.5 kW (25 HP)				<b>F:</b> 30 kW (40 HP)				
<b>A:</b> 15 kW (20 HP)				<b>E:</b> 37 kW (50 HP)				
<b>A145</b> (145 cm <sup>3</sup> /rev)	<b>L:</b> Foot Mtg.	<b>R:</b> Clockwise*1 (Normal)	<b>09:</b> Constant Power Control Type	<b>B:</b> 18.5 kW (20 HP)	<b>F:</b> 45 kW (60 HP)	<b>S:</b> Side Port	<b>60</b>	Refer to ★3
<b>C:</b> 22 kW (30 HP)				<b>G:</b> 55 kW (75 HP)				
<b>D:</b> 30 kW (40 HP)				<b>H:</b> 75 kW (100 HP)				

★1. Available to supply pump with anti-clockwise rotation. Consult Yuken for details.

★2. Specify control pressure of A16/A37/A56 with lower than Maximum Operating Pressure depending on Input Power Setting.

Model	Maximum Operating Pressure MPa (PSI)								
	1.5 kW (2 HP)	2.2 kW (3 HP)	3.7 kW (5 HP)	5.5 kW (7.5 HP)	7.5 kW (10 HP)	11 kW (15 HP)	15 kW (20 HP)	18.5 kW (25 HP)	22 kW (30 HP)
A16	10.5 (1520)	16 (2320)	21 (3050)	21 (3050)	—	—	—	—	—
A37	—	—	16 (2320)	21 (3050)	21 (3050)	21 (3050)	—	—	—
A56	—	—	10.5 (1520)	14 (2030)	17.5 (2540)	21 (3050)	21 (3050)	21 (3050)	21 (3050)

★3. Design Standards: None ..... Japanese Standard "JIS"  
 80 ..... European Design Standard  
 950 ..... N. American Design Standard

**Pipe Flange Kits**

Pipe flange kits are available. When ordering, specify the kit number from the table below.

Pump Model Numbers	Name of Port	Pipe Flange Kit Numbers						
		Threaded Connection			Socket Welding*1		Butt Welding	
		Japanese Std. "JIS"	European Design Std.	N. American Design Standard	Japanese Std. "JIS" & European Design Std.	N. American Design Standard	Japanese Std. "JIS" & European Design Std.	N. American Design Standard
A16-*-R-09	Suction	F5-06-A-10	F5-06-A-1080	—	F5-06-B-10	F5-06-B-1090	F5-06-C-10	F5-06-C-1090
	Discharge	—*2	—*2	—*2	—*2	—*2	—*2	—*2
A37-*-R-09 A56-*-R-09	Suction	F5-10-A-10	F5-10-A-1080	—	F5-10-B-10	F5-10-B-1090	F5-10-C-10	F5-10-C-1090
	Discharge	F5-06-A-10	F5-06-A-1080	—	F5-06-B-10	F5-06-B-1090	F5-06-C-10	F5-06-C-1090
A70-*-R-09	Suction	F5-12-A-10	F5-12-A-1080	—	F5-12-B-10	F5-12-B-1090	F5-12-C-10	F5-12-C-1090
	Discharge	F5-08-A-10	F5-08-A-1080	—	F5-08-B-10	F5-08-B-1090	F5-08-C-10	F5-08-C-1090
A145-*-R-09	Suction	F5-16-A-10	F5-16-A-1080	—	F5-16-B-10	F5-16-B-1090	F5-16-C-10	F5-16-C-1090
	Discharge	F5-10-A-10	F5-10-A-1080	—	F5-10-B-10	F5-10-B-1090	F5-10-C-10	F5-10-C-1090

★1. In case of using socket welding flanges, there is a case where the operating pressure should be set lower than the normal because of strength of hat flanges. Therefore, please pay cautious attention to the operating pressure when the socket welding flanges are used.

★2. Discharge port for pump model "A16" is available only the threaded connections.

★3. As dimensions of the pipe flange mounting surface are conformed to SAE 4 Bolt Split Flange (Standard Pressure Series), pipe flanges conforming to the SAE Standards can be used.

● Detail of the pipe flange kits are shown on page 824.



### Typical Performance Characteristics at 1500 r/min

**A16**

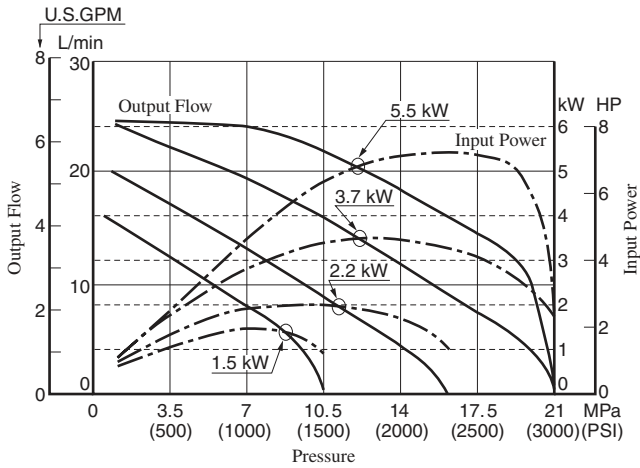

**A70**

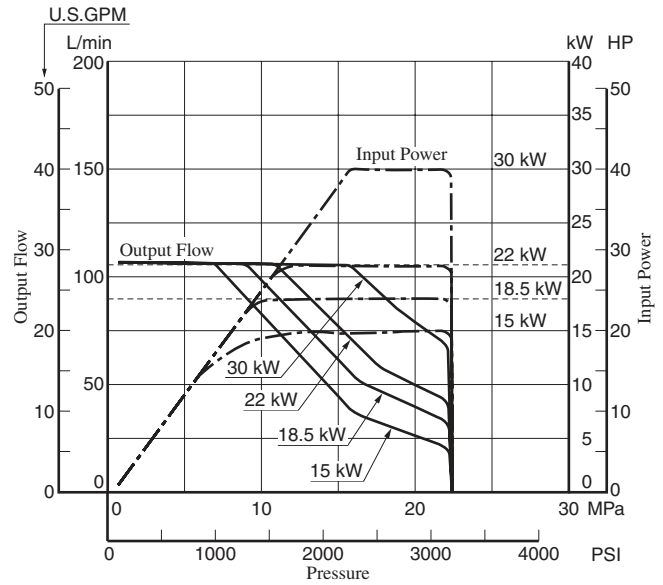

**A37**

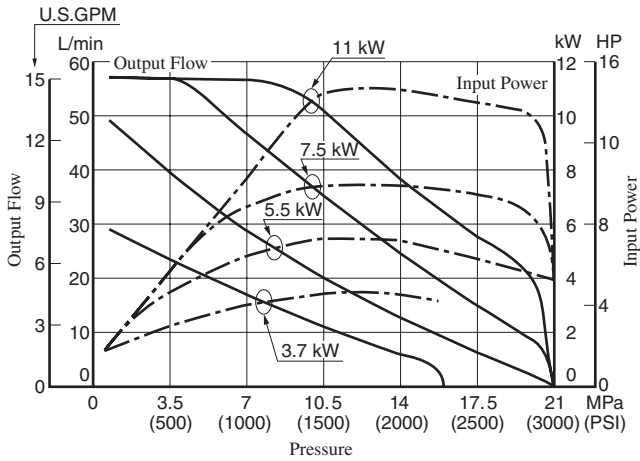

**A145**

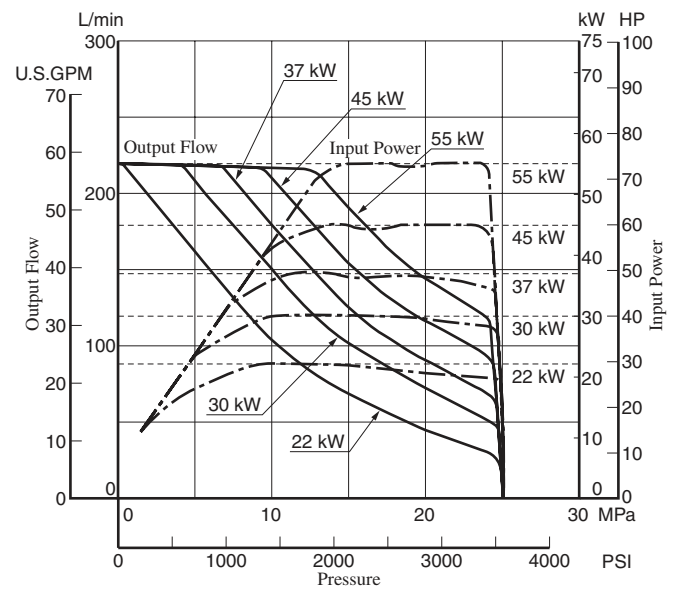

**A56**

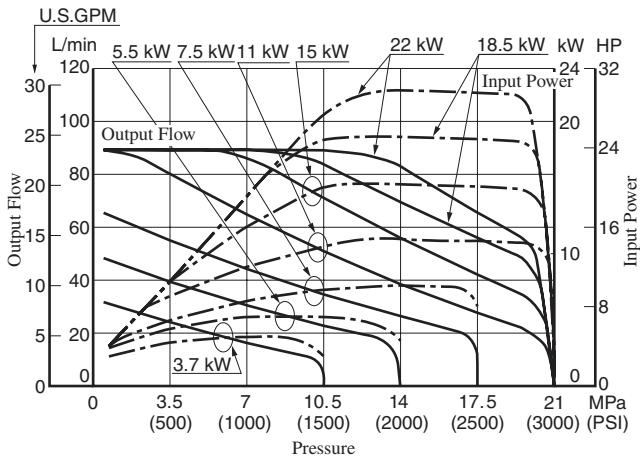

Flange Mtg. : A16-F-R-09-\*-K-32/3280/32950

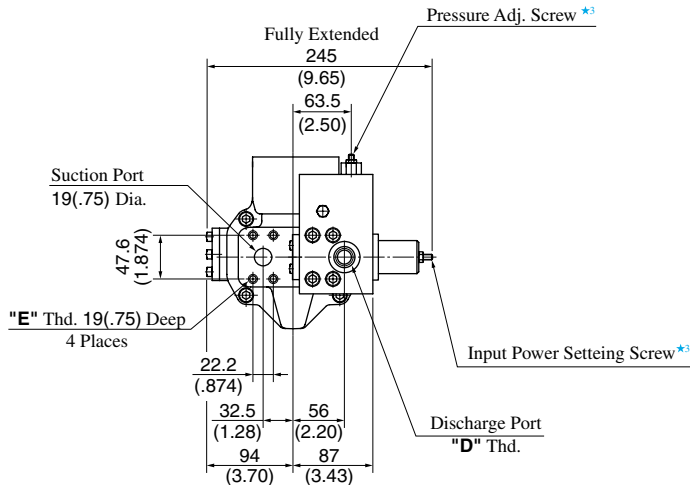
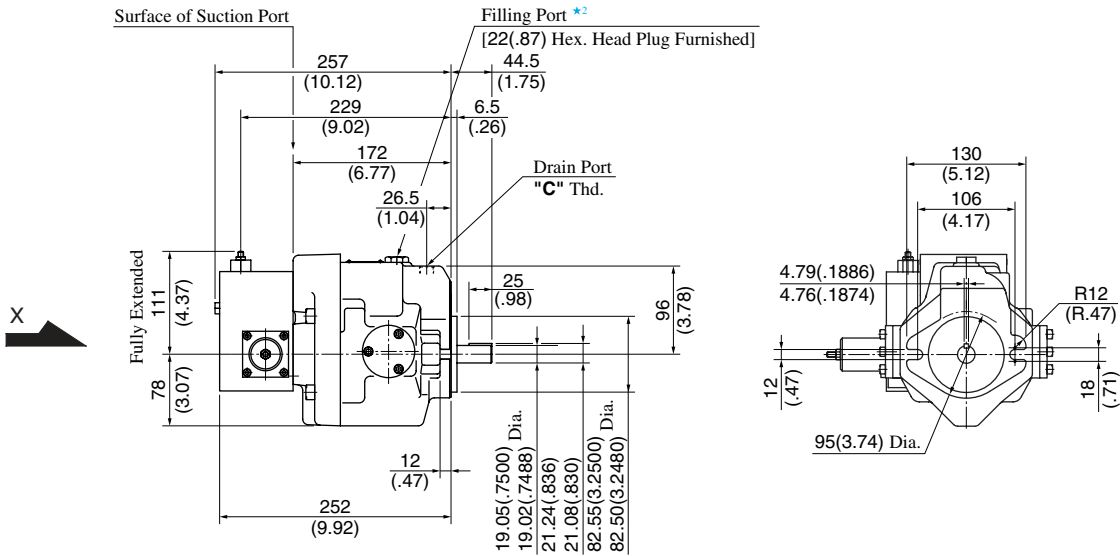

View Arrow X

Model Numbers	"C" Thd.	"D" Thd.	"E" Thd.
A16-F-R-09-*-K-32	Rc 3/8	G 1/2 *1	M10
A16-F-R-09-*-K-3280	3/8 BSP.F	1/2 BSP.F	
A16-F-R-09-*-K-32950	SAE #8	SAE #8	3/8-16 UNC

★ 1. Detail of Discharge Port  
[For Japanese Standard]

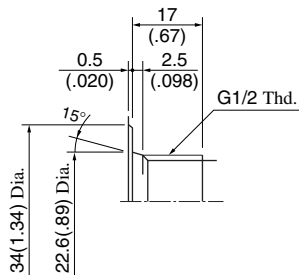

★ 2. Install the pump so that the "Filling Port" is at the top.

★ 3. Do not touch the screw because it is adjusted at the time of shipment.

**DIMENSIONS IN  
MILLIMETRES (INCHES)**

● **Foot Mounting Type**

Mounting bracket is common to that of pressure compensator model.  
Refer to [page 45](#) for the dimensions of mounting bracket.



Flange Mtg. : A37-F-R-09-\*-K-32/3280/32950

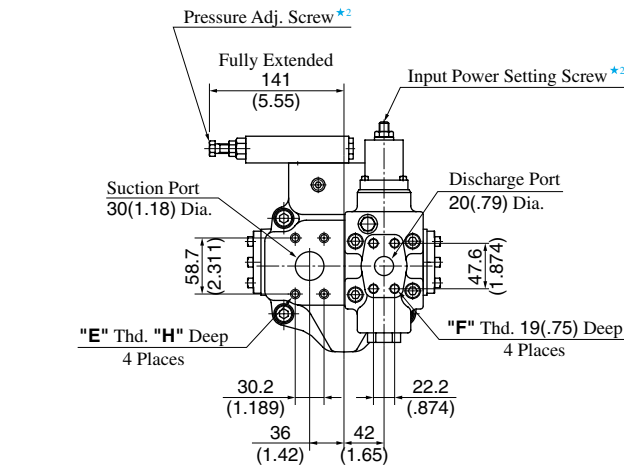
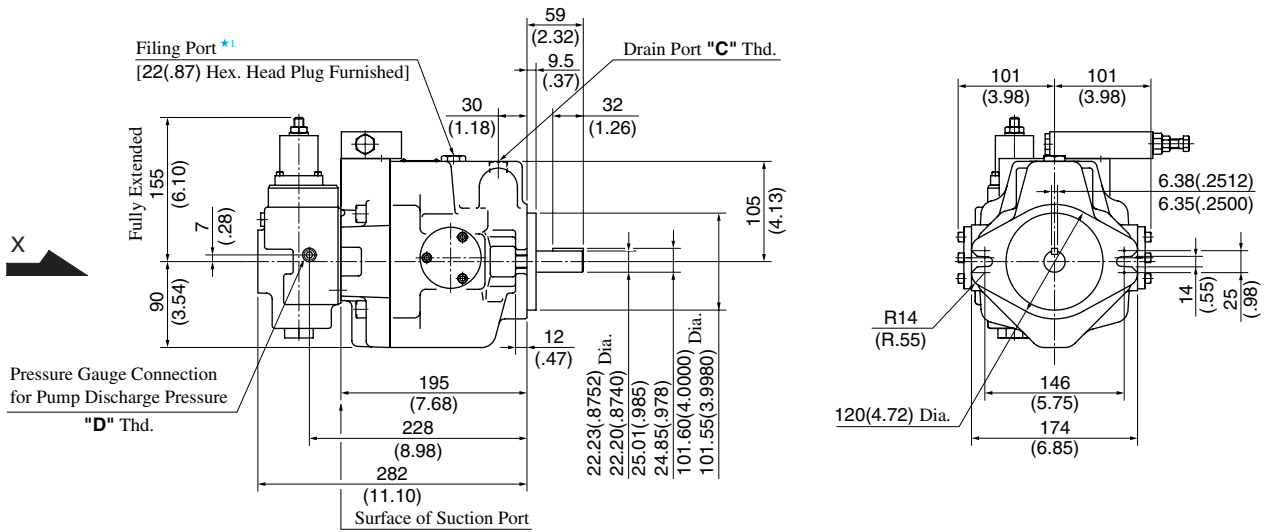

View Arrow X

- ★ 1. Install the pump so that the "Filling Port" is at the top.
- ★ 2. Do not touch the screw because it is adjusted at the time of shipment.

Model Numbers	"C" Thd.	"D" Thd.	"E" Thd.	"F" Thd.	"H" mm (IN.)
A37-F-R-09-*-K-32	Rc 1/2	Rc 1/4	M10	M10	19 (.75)
A37-F-R-09-*-K-3280	1/2 BSP.F	1/4 BSP.Tr			
A37-F-R-09-*-K-32950	SAE #10	SAE #4	7/16-14 UNC	3/8-16 UNC	20 (.79)

DIMENSIONS IN MILLIMETRES (INCHES)

Foot Mtg. : A37-L-R-09-\*-K-32/3280/32950

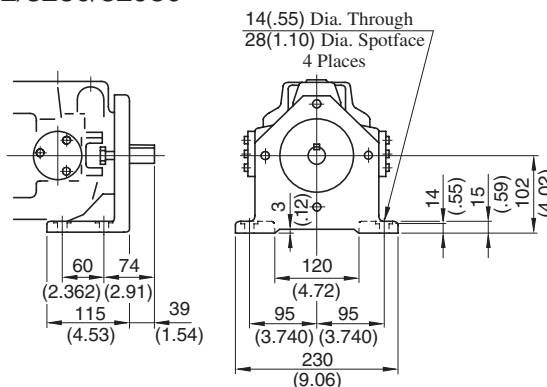

• For other dimensions, refer to "Flange Mtg.".

Flange Mtg. : A56-F-R-09-\*-K-32/3280/32950

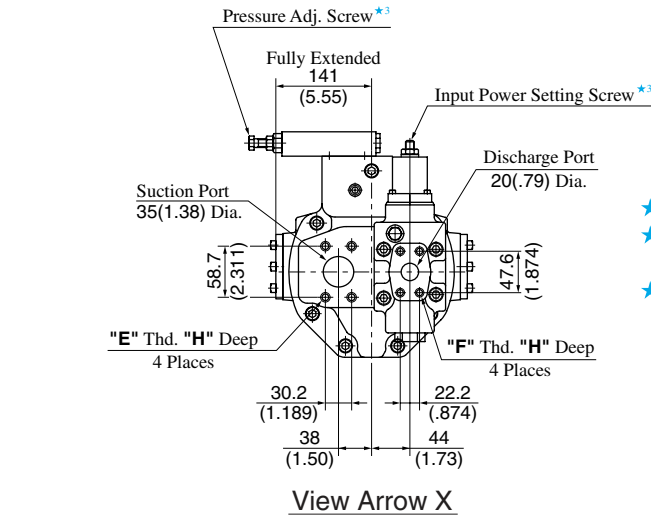
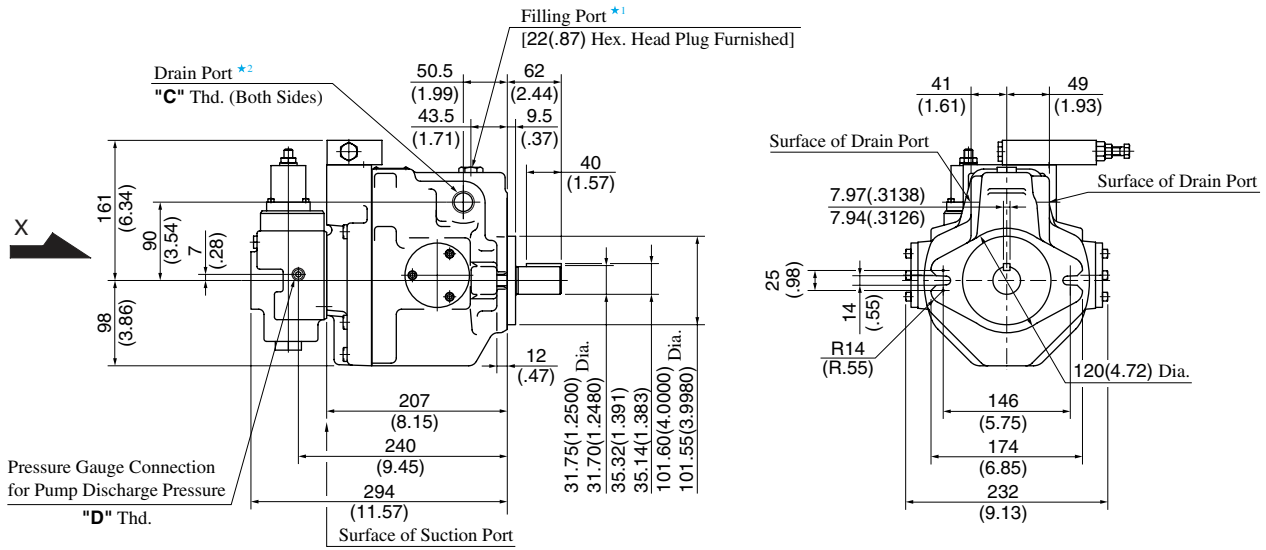

- ★ 1. Install the pump so that the "Filling Port" is at the top.
- ★ 2. Use either port of two drain ports at your option. Keep the remaining port plugged.
- ★ 3. Do not touch the screw because it is adjusted at the time of shipment.

Model Numbers	"C" Thd.	"D" Thd.	"E" Thd.	"F" Thd.	"H" mm (IN.)
A56-F-R-09-*-K-32	Rc 3/4	Rc 1/4	M10	M10	19 (.75)
A56-F-R-09-*-K-3280	3/4 BSP.F	1/4 BSP.Tr			
A56-F-R-09-*-K-32950	SAE #12	SAE #4	7/16-14 UNC	3/8-16 UNC	20 (.79)

**DIMENSIONS IN MILLIMETRES (INCHES)**

Foot Mtg. : A56-L-R-09-\*-K-32/3280/32950

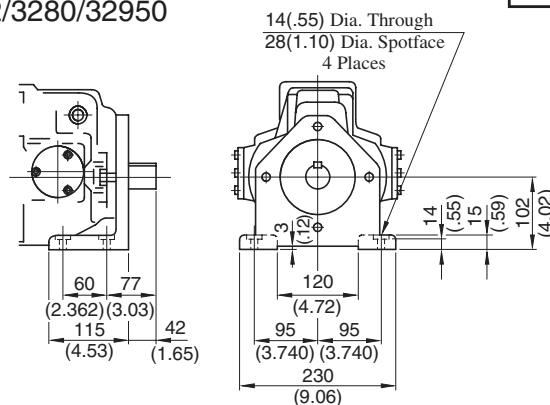

• For other dimensions, refer to "Flange Mtg.".

Flange Mtg. : A70-FR09\*S-60/6080/60950

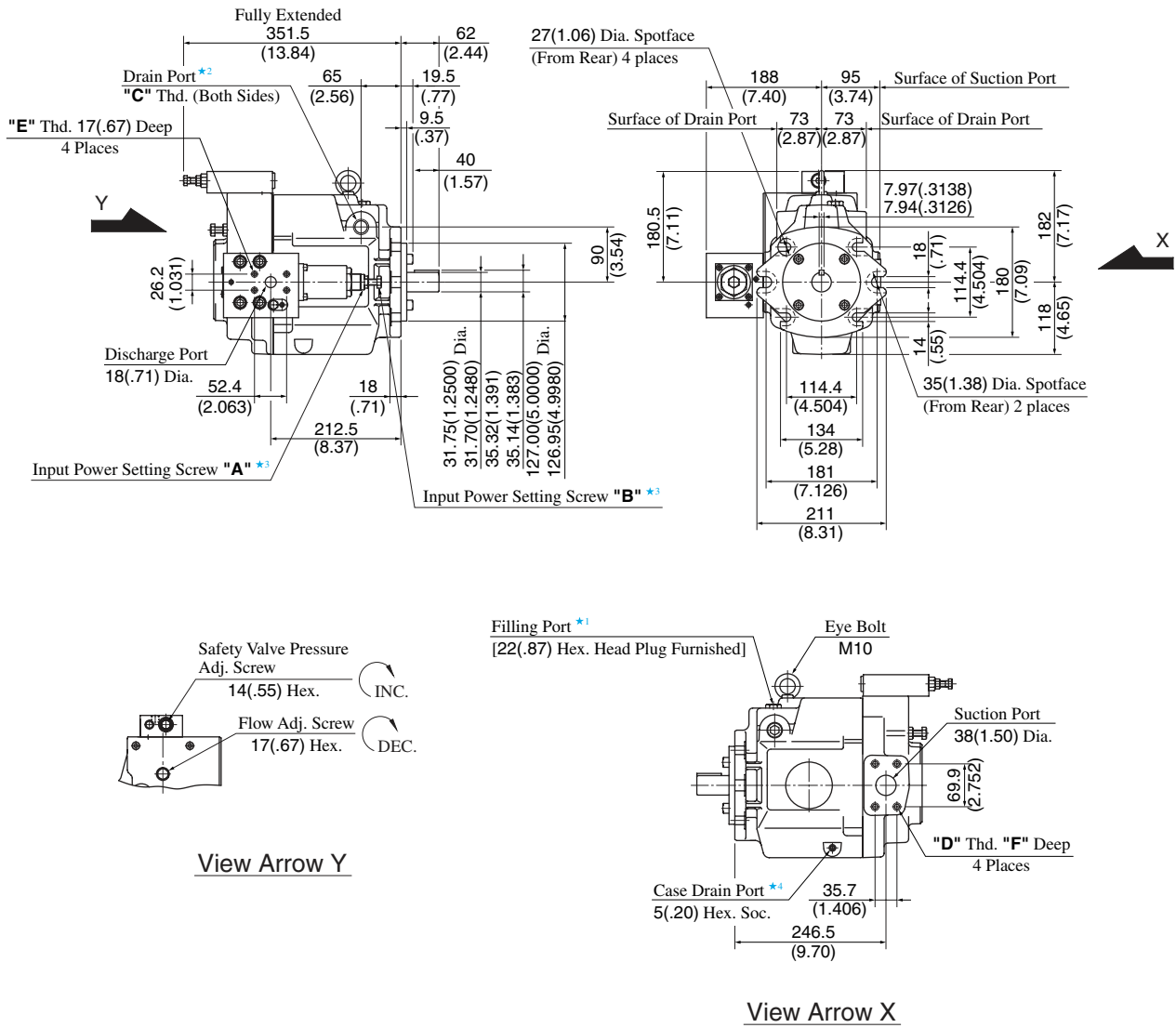

- ★ 1. Install the pump so that the "Filling Port" is at the top.
- ★ 2. Use either port of two drain ports at your option. Keep the remaining port plugged.
- ★ 3. Do not touch the screw because it is adjusted at the time of shipment.
- ★ 4. Case drain port is available for use when draining hydraulic fluid from pump casing.

Model Numbers	"C" Thd.	"D" Thd.	"E" Thd.	F mm (IN.)
A70-FR09*S-60	Rc 3/4	M12	M10	19 (.75)
A70-FR09*S-6080	3/4 BSP.F			
A70-FR09*S-60950	SAE #12	1/2-13 UNC	3/8-16 UNC	21 (.83)

DIMENSIONS IN MILLIMETRES (INCHES)

● Foot Mounting Type

Mounting bracket is common to that of pressure compensator model. Refer to page 48 for the dimensions of mounting bracket.

Flange Mtg. : A145-FR09\*S-60/6080/60950

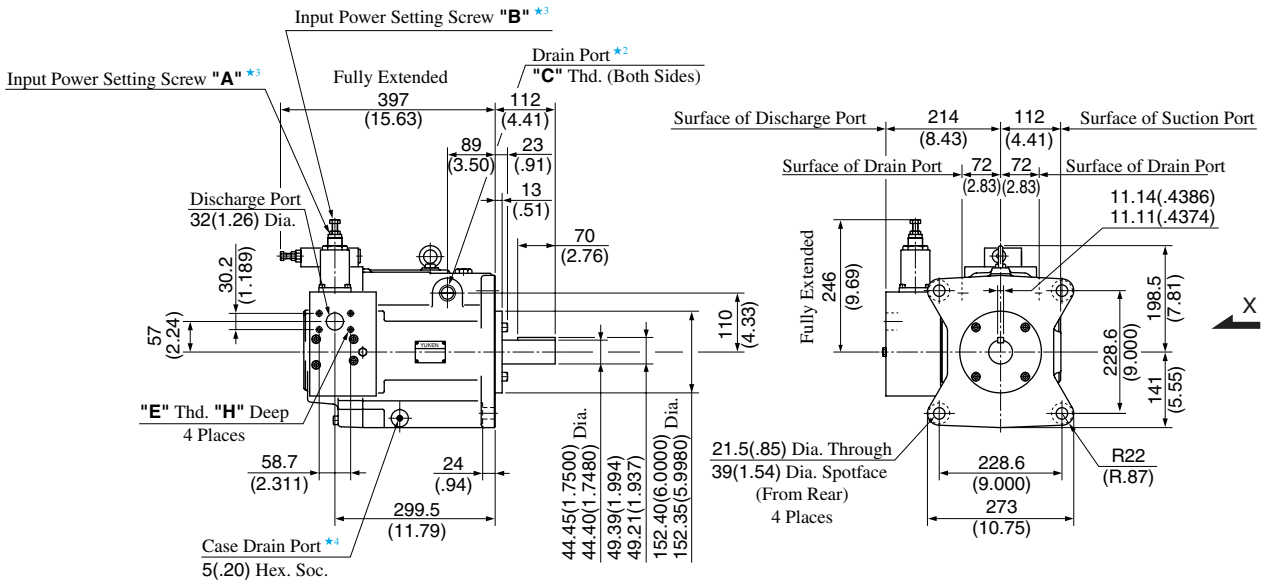

- ★ 1. Install the pump so that the "Filling Port" is at the top.
- ★ 2. Use either port of two drain ports at your option. Keep the remaining port plugged.
- ★ 3. Do not touch the screw because it is adjusted at the time of shipment.
- ★ 4. Case drain port is available for use when draining hydraulic fluid from pump casing.

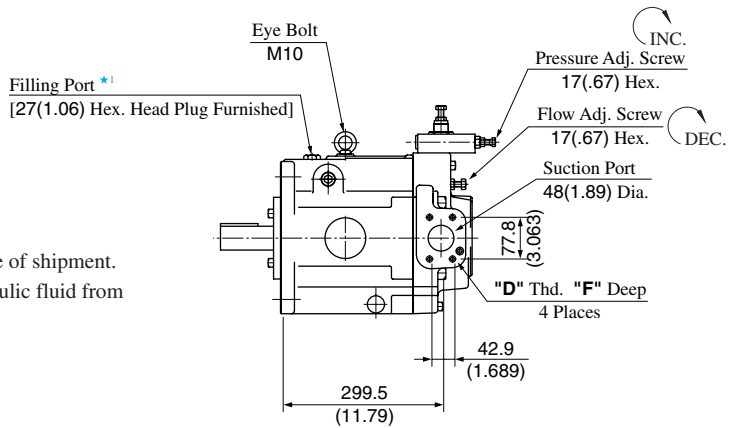

View Arrow X

Model Numbers	"C" Thd.	"D" Thd.	"E" Thd.	F mm (IN.)	H mm (IN.)
A145-FR09*S-60	Rc 3/4	M12	M10	19 (.75)	19 (.75)
A145-FR09*S-6080	3/4 BSP.F				
A145-FR09*S-60950	SAE #12	1/2-13 UNC	7/16-14 UNC	21 (.83)	20 (.79)

DIMENSIONS IN MILLIMETRES (INCHES)

● **Foot Mounting Type**

Mounting bracket is common to that of pressure compensator model.  
 Refer to page 50 for the dimensions of mounting bracket.



# "A" Series Variable Displacement Piston Pumps – Double Pumps, Pressure Compensator Type

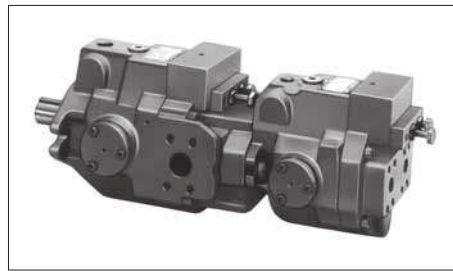

Graphic Symbol

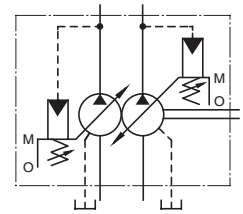

## Specifications

Model Numbers		Geometric Displacement cm <sup>3</sup> /rev (cu.in./rev)	Min. Adj. Flow cm <sup>3</sup> /rev (cu.in./rev)	Operating Pressure MPa (PSI)		Shaft Speed Range r/min		Approx. Mass kg (lbs.)	
				Rated	Intermittent	Max.	Min.	Flange Mtg.	Foot Mtg.
A1616-∗R01∗01∗∗K-32∗	Outboard Pump	15.8 (.964)	4 (.244)	16 (2320)	21 (3050)	1800	600	35.5 (98.3)	37.7 (83.1)
	Inboard Pump	15.8 (.964)	4 (.244)	16 (2320)	21 (3050)				
A1622-∗R01∗01∗∗K-32∗	Outboard Pump	15.8 (.964)	4 (.244)	16 (2320)	21 (3050)	1800	600	35.5 (98.3)	37.7 (83.1)
	Inboard Pump	22.2 (1.355)	6 (.366)	16 (2320)	16 (2320)				
A2222-∗R01∗01∗∗K-32∗	Outboard Pump	22.2 (1.355)	6 (.366)	16 (2320)	16 (2320)	1800	600	35.5 (98.3)	37.7 (83.1)
	Inboard Pump	22.2 (1.355)	6 (.366)	16 (2320)	16 (2320)				
A1637-∗R01∗01∗∗K-32∗	Outboard Pump	15.8 (.964)	4 (.244)	16 (2320)	21 (3050)	1800	600	50 (110)	54.3 (120)
	Inboard Pump	36.9 (2.25)	10 (.610)	16 (2320)	21 (3050)				
A2237-∗R01∗01∗∗K-32∗	Outboard Pump	22.2 (1.355)	6 (.366)	16 (2320)	16 (2320)	1800	600	50 (110)	54.3 (120)
	Inboard Pump	36.9 (2.25)	10 (.610)	16 (2320)	21 (3050)				
A1656-∗R01∗01∗∗K-32∗	Outboard Pump	15.8 (.964)	4 (.244)	16 (2320)	21 (3050)	1800	600	54.5 (120)	58.8 (130)
	Inboard Pump	56.2 (3.43)	12 (.732)	16 (2320)	21 (3050)				
A2256-∗R01∗01∗∗K-32∗	Outboard Pump	22.2 (1.355)	6 (.366)	16 (2320)	16 (2320)	1800	600	54.5 (120)	58.8 (130)
	Inboard Pump	56.2 (3.43)	12 (.732)	16 (2320)	21 (3050)				
A1670-∗R01∗01∗∗-60∗	Outboard Pump	15.8 (.964)	4 (.244)	16 (2320)	21 (3050)	1800	600	77.5 (171)	89.5 (197)
	Inboard Pump	70.0 (4.27)	30 (1.831)	25 (3630)	28 (4060)				
A2270-∗R01∗01∗∗-60∗	Outboard Pump	22.2 (1.355)	6 (.366)	16 (2320)	16 (2320)	1800	600	77.5 (171)	89.5 (197)
	Inboard Pump	70.0 (4.27)	30 (1.831)	25 (3630)	28 (4060)				
A3770-∗R01∗01∗∗-60∗	Outboard Pump	36.9 (2.25)	10 (.610)	16 (2320)	21 (3050)	1800	600	86.5 (191)	98.5 (217)
	Inboard Pump	70.0 (4.27)	30 (1.831)	25 (3630)	28 (4060)				
A1690-∗R01∗01∗∗-60∗	Outboard Pump	15.8 (.964)	4 (.244)	16 (2320)	21 (3050)	1800	600	88 (194)	108.5 (239)
	Inboard Pump	91.0 (5.55)	56 (3.42)	25 (3630)	28 (4060)				
A2290-∗R01∗01∗∗-60∗	Outboard Pump	22.2 (1.355)	6 (.366)	16 (2320)	16 (2320)	1800	600	88 (194)	108.5 (239)
	Inboard Pump	91.0 (5.55)	56 (3.42)	25 (3630)	28 (4060)				
A3790-∗R01∗01∗∗-60∗	Outboard Pump	36.9 (2.25)	10 (.610)	16 (2320)	21 (3050)	1800	600	100.5 (222)	121 (267)
	Inboard Pump	91.0 (5.55)	56 (3.42)	25 (3630)	28 (4060)				
A5690-∗R01∗01∗∗-60∗	Outboard Pump	56.2 (3.43)	12 (.732)	16 (2320)	21 (3050)	1800	600	107.5 (237)	128 (282)
	Inboard Pump	91.0 (5.55)	56 (3.42)	25 (3630)	28 (4060)				
A16145-∗R01∗01∗∗-60∗	Outboard Pump	15.8 (.964)	4 (.244)	16 (2320)	21 (3050)	1800	600	109 (240)	134 (295)
	Inboard Pump	145 (8.85)	83 (5.06)	25 (3630)	28 (4060)				
A22145-∗R01∗01∗∗-60∗	Outboard Pump	22.2 (1.355)	6 (.366)	16 (2320)	16 (2320)	1800	600	109 (240)	134 (295)
	Inboard Pump	145 (8.85)	83 (5.06)	25 (3630)	28 (4060)				
A37145-∗R01∗01∗∗-60∗	Outboard Pump	36.9 (2.25)	10 (.610)	16 (2320)	21 (3050)	1800	600	121.5 (268)	146.5 (323)
	Inboard Pump	145 (8.85)	83 (5.06)	25 (3630)	28 (4060)				
A56145-∗R01∗01∗∗-60∗	Outboard Pump	56.2 (3.43)	12 (.732)	16 (2320)	21 (3050)	1800	600	128.5 (283)	153.5 (338)
	Inboard Pump	145 (8.85)	83 (5.06)	25 (3630)	28 (4060)				

Consult Yuken when detailed material such as dimensions figures is required.

**Model Number Designation**

A1637	-F	R	Outboard Pump		Inboard Pump (Driven End)		S	K	-32	*	
			01	C	01	C					
Series Number	Mounting	Direction of Rotation	Control Type	Pres. Adj. Range MPa(PaSI)	Control Type	Pres. Adj. Range MPa(PaSI)	Port Position of Outboard Pump	Shaft Extension	Design Number	Design Std.	
A1616 (15.8/15.8 cm <sup>3</sup> /rev)		Viewed from Shaft End	01: Pressure Compensator Type	B: 1.2- 7 (170-1020) C: 1.2-16 (170-2320) H: 1.2-21 (170-3050)	01: Pressure Compensator Type	B: 1.2- 7 (170-1020) C: 1.2-16 (170-2320) H: 1.2-21 (170-3050)	None: Axial Port	None: Keyed Shaft	32	Refer to ★2	
A1622 (15.8/22.2 cm <sup>3</sup> /rev)				B: 1.2- 7 (170-1020) C: 1.2-16 (170-2320)		B: 1.2- 7 (170-1020) C: 1.2-16 (170-2320)			32		
A2222 (22.2/22.2 cm <sup>3</sup> /rev)				B: 1.2- 7 (170-1020) C: 1.2-16 (170-2320)		B: 1.2- 7 (170-1020) C: 1.2-16 (170-2320)			32		
A1637 (15.8/36.9 cm <sup>3</sup> /rev)				B: 1.2- 7 (170-1020) C: 1.2-16 (170-2320) H: 1.2-21 (170-3050)		B: 1.2- 7 (170-1020) C: 1.2-16 (170-2320)			32		
A2237 (22.2/36.9 cm <sup>3</sup> /rev)				B: 1.2- 7 (170-1020) C: 1.2-16 (170-2320)		B: 1.2- 7 (170-1020) C: 1.2-16 (170-2320)			32		
A1656 (15.8/56.2 cm <sup>3</sup> /rev)				B: 1.2- 7 (170-1020) C: 1.2-16 (170-2320) H: 1.2-21 (170-3050)		B: 1.2- 7 (170-1020) C: 1.2-16 (170-2320) H: 1.2-21 (170-3050)			32		
A2256 (22.2/56.2 cm <sup>3</sup> /rev)				B: 1.2- 7 (170-1020) C: 1.2-16 (170-2320)		B: 1.2- 7 (170-1020) C: 1.2-16 (170-2320)			32		
A1670 (15.8/70.0 cm <sup>3</sup> /rev)				F: Flange Mtg.		B: 1.2- 7 (170-1020) C: 1.2-16 (170-2320) H: 1.2-21 (170-3050)			S: Side Port		60
A2270 (22.2/70.0 cm <sup>3</sup> /rev)				R: ★1 Clockwise (Normal)		B: 1.2- 7 (170-1020) C: 1.2-16 (170-2320)			None: Axial Port		60
A3770 (36.9/70.0 cm <sup>3</sup> /rev)				L: Foot Mtg.		B: 1.2- 7 (170-1020) C: 1.2-16 (170-2320) H: 1.2-21 (170-3050)			None: Axial Port		60
A1690 (15.8/91.0 cm <sup>3</sup> /rev)				B: 1.2- 7 (170-1020) C: 1.2-16 (170-2320) H: 1.2-21 (170-3050)		B: 1.2- 7 (170-1020) C: 1.2-16 (170-2320)			None: Keyed Shaft		60
A2290 (22.2/91.0 cm <sup>3</sup> /rev)				B: 1.2- 7 (170-1020) C: 1.2-16 (170-2320)		B: 1.2- 7 (170-1020) C: 1.2-16 (170-2320)			None: Keyed Shaft		60
A3790 (36.9/91.0 cm <sup>3</sup> /rev)				B: 1.2- 7 (170-1020) C: 1.2-16 (170-2320) H: 1.2-21 (170-3050)		B: 1.2- 7 (170-1020) C: 1.2-16 (170-2320) H: 1.2-21 (170-3050)			None: Keyed Shaft		60
A5690 (56.2/91.0 cm <sup>3</sup> /rev)				B: 1.2- 7 (170-1020) C: 1.2-16 (170-2320) H: 1.2-21 (170-3050)		B: 1.2- 7 (170-1020) C: 1.2-16 (170-2320)			None: Keyed Shaft		60
A16145 (15.8/145 cm <sup>3</sup> /rev)				B: 1.2- 7 (170-1020) C: 1.2-16 (170-2320) H: 1.2-21 (170-3050)		B: 1.2- 7 (170-1020) C: 1.2-16 (170-2320)			None: Keyed Shaft		60
A22145 (22.2/145 cm <sup>3</sup> /rev)	B: 1.2- 7 (170-1020) C: 1.2-16 (170-2320)	B: 1.2- 7 (170-1020) C: 1.2-16 (170-2320)	None: Keyed Shaft	60							
A37145 (36.9/145 cm <sup>3</sup> /rev)	B: 1.2- 7 (170-1020) C: 1.2-16 (170-2320) H: 1.2-21 (170-3050)	B: 1.2- 7 (170-1020) C: 1.2-16 (170-2320)	None: Keyed Shaft	60							
A56145 (56.2/145 cm <sup>3</sup> /rev)	B: 1.2- 7 (170-1020) C: 1.2-16 (170-2320) H: 1.2-21 (170-3050)	B: 1.2- 7 (170-1020) C: 1.2-16 (170-2320)	None: Keyed Shaft	60							

★1. Available to supply pump with anti-clockwise rotation. Consult Yuken for details.

★2. Design Standards: None ..... Japanese Standard "JIS"  
80 ..... European Design Standard  
950 ..... N. American Design Standard



## "A" Series Piston Pumps – Variable / Fixed Double Pumps

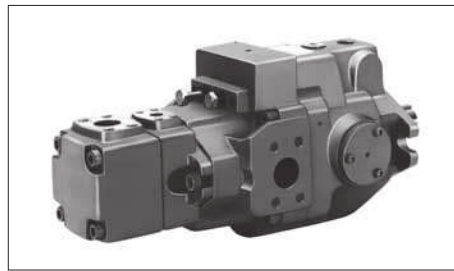

Graphic Symbol

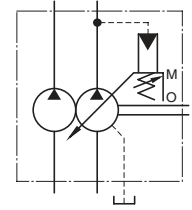

### Model Number Designation

A16R1	-F	R	Inboard Pump (Driven End)		Outboard Pump			K	-32	*
			01	B	-23	A	A			
Series Number	Mounting	Direction of Rotation	Control Type	Pres. Adj. Range MPa(PSI)	Nominal Displacement cm <sup>3</sup> /rev	Discharge Port Position	Suction Port Position	Shaft Extension	Design Number	Design Std.
A16R1	F: Flange Mtg. L: Foot Mtg.	(Viewed from Shaft End) R: *1 Clockwise (Normal)	01: Pressure Compensator Type	B: 1.2 - 7 (170 - 1020) C: 1.2 - 16 (170 - 2320) H: 1.2 - 21 (170 - 3050)	6, 8 10, 12 14, 17 19, 23 25, 31	A: Up	A: Up	K: Keyed Shaft	32	Refer to *2
A22R1				B: 1.2 - 7 (170 - 1020) C: 1.2 - 16 (170 - 2320)					32	
A37R1				B: 1.2 - 7 (170 - 1020) C: 1.2 - 16 (170 - 2320) H: 1.2 - 21 (170 - 3050)					32	
A56R1				B: 1.2 - 7 (170 - 1020) C: 1.5 - 16 (220 - 2320) H: 1.8 - 21 (260 - 3050) K: 2.0 - 28 (290 - 4060)					32	
A70R1				B: 1.2 - 7 (170 - 1020) C: 1.5 - 16 (220 - 2320) H: 1.8 - 21 (260 - 3050) K: 2.0 - 28 (290 - 4060)					60	
A90R1				B: 1.2 - 7 (170 - 1020) C: 1.5 - 16 (220 - 2320) H: 1.8 - 21 (260 - 3050) K: 2.0 - 28 (290 - 4060)					60	
A145R1				B: 1.2 - 7 (170 - 1020) C: 1.5 - 16 (220 - 2320) H: 1.8 - 21 (260 - 3050) K: 2.0 - 28 (290 - 4060)					60	
A70R2				B: 1.2 - 7 (170 - 1020) C: 1.5 - 16 (220 - 2320) H: 1.8 - 21 (260 - 3050) K: 2.0 - 28 (290 - 4060)					60	
A90R2				B: 1.2 - 7 (170 - 1020) C: 1.5 - 16 (220 - 2320) H: 1.8 - 21 (260 - 3050) K: 2.0 - 28 (290 - 4060)					60	
A145R2				B: 1.2 - 7 (170 - 1020) C: 1.5 - 16 (220 - 2320) H: 1.8 - 21 (260 - 3050) K: 2.0 - 28 (290 - 4060)					60	

\*1. Available to supply pump with anti-clockwise rotation. Consult Yuken for details.

\*2. Design Standards: None ..... Japanese Standard "JIS"  
80 ..... European Design Standard  
950 ..... N. American Design Standard

Consult Yuken when detailed material such as dimensions figures is required.

## Specifications

Model Numbers	Geometric Displacement cm <sup>3</sup> /rev (cu.in./rev)	Operating Pressure MPa (PSI)		Shaft Speed Range r/min		Approx. Mass kg (lbs.)	
		Rated	Intermittent	Max.	Min.	Flange Mtg.	Foot Mtg.
A16R1-*R01*-*AAK-32*	Outboard Pump	Refer to the following table		1800	750	28.8 (63.5)	31.0 (68.4)
	Inboard Pump	15.8 (.964)	16 (2320)				
A22R1-*R01*-*AAK-32*	Outboard Pump	Refer to the following table		1800	750	28.8 (63.5)	31.0 (68.4)
	Inboard Pump	22.2 (1.355)	16 (2320)				
A37R1-*R01*-*AAK-32*	Outboard Pump	Refer to the following table		1800	750	39 (86.0)	43.3 (95.5)
	Inboard Pump	36.9 (2.25)	16 (2320)				
A56R1-*R01*-*AAK-32*	Outboard Pump	Refer to the following table		1800	750	47 (104)	51.3 (113)
	Inboard Pump	56.2 (3.43)	16 (2320)				
A70R1-*R01*-*AA-60*	Outboard Pump	Refer to the following table		1800	750	66 (146)	78 (172)
	Inboard Pump	70.0 (4.27)	25 (3630)				
A90R1-*R01*-*AA-60*	Outboard Pump	Refer to the following table		1800	750	82 (181)	105 (232)
	Inboard Pump	91.0 (5.55)	25 (3630)				
A145R1-*R01*-*AA-60*	Outboard Pump	Refer to the following table		1800	750	102 (225)	129 (284)
	Inboard Pump	145 (8.85)	25 (3630)				
A70R2-*R01*-*AA-60*	Outboard Pump	Refer to the following table		1800	600	72.5 (160)	84.5 (186)
	Inboard Pump	70.0 (4.27)	25 (3630)				
A90R2-*R01*-*AA-60*	Outboard Pump	Refer to the following table		1800	600	91.5 (202)	112 (247)
	Inboard Pump	91.0 (5.55)	25 (3630)				
A145R2-*R01*-*AA-60*	Outboard Pump	Refer to the following table		1800	600	112 (247)	137 (302)
	Inboard Pump	145 (8.85)	25 (3630)				

### ● Geometric Displacement and Max. Pressure of Outboard Pump

Model Numbers	Geometric Displacement cm <sup>3</sup> /rev (cu.in./rev)	Max Pres. MPa (PSI)	
		Anti-Wear Type	R & O Type
A*R1-*R01*-6	5.8 (.354)	21 (3050)	16 (2320)
A*R1-*R01*-8	8.0 (.488)		
A*R1-*R01*-10	9.4 (.574)		
A*R1-*R01*-12	12.2 (.744)		
A*R1-*R01*-14	13.7 (.836)		
A*R1-*R01*-17	16.6 (1.013)		
A*R1-*R01*-19	18.6 (1.135)		
A*R1-*R01*-23	22.7 (1.385)	17.5 (2540)	
A*R1-*R01*-25	25.3 (1.544)	15 (2180)	15 (2180)
A*R1-*R01*-31	31.0 (1.892)	12 (1740)	12 (1740)
A*R2-*R01*-26	26.6 (1.623)	21 (3050)	14 (2030)
A*R2-*R01*-33	33.3 (2.03)		
A*R2-*R01*-41	41.3 (2.52)		
A*R2-*R01*-47	47.2 (2.88)		
A*R2-*R01*-53	52.5 (3.20)		
A*R2-*R01*-59	58.2 (3.55)		
A*R2-*R01*-65	64.7 (3.95)		





## Hydraulic Fluids

### Hydraulic Fluids

Use petroleum base oils such as anti-wear type hydraulic oils or R & O (Rust and Oxidation inhibitor) type hydraulic oils equivalent to ISO VG-32 or 46.

The recommended viscosity range is from 20 to 400 mm<sup>2</sup>/s (98 to 1800 SSU) and temperature range is from 0 to 60°C (32 to 140°F), both of which have to be satisfied for the use of the above hydraulic oils.

### Control of Contamination

Due caution must be paid to maintaining control over contamination of the operating oil which can otherwise lead to breakdowns and shorten the life of the unit. Please maintain the degree of contamination within NAS Grade 10.

The suction port must be equipped with at least a 100 μm (150 mesh) reservoir type filter and the return line must have a line filter of under 10 μm.

## Instructions

### Mounting

When installing the pump the filling port should be positioned upwards.

### Alignment of Shaft

Employ a flexible coupling whenever possible, and avoid any stress from bending or thrust.

Maximum permissible misalignment is less than 0.1 mm (.0039 inches) TIR and maximum permissible misangular is less than 0.2°.

### Suction Pressure

Permissible suction pressure at suction port of the pump is between -16.7 and +50 kPa (5 in.Hg Vacuum and 7 PSIG). In case of the speed is over 1800 r/min, adjust the pressure 0 to +50 kPa (0 to 7 PSIG).

For piping to the suction port, use the pipes of the same diameter as that of the specified pipe flange to be used.

Make sure that the height of the pump suction port is within one metre (3.3ft.) from the oil level in the reservoir.

### Hints on Piping

When using steel pipes for the suction or discharge ports, excessive load from the piping to the pump generates excessive noise.

Whenever there is fear of excessive load, please use rubber hoses.

### Suction Piping

In case the pump is installed above the oil level, the suction piping and suction line filter should be located lower than the pump position to prevent air in the suction line.

### Drain Piping

Install drain piping according to the chart and ensure that pressure within the pump housing should be maintained at a normal pressure of less than 0.1 MPa (15 PSI) and surge pressure of less than 0.5 MPa (70 PSI).

Length of piping should be less than 1 m (3.3 ft.), and the pipe end should be submerged in oil.

[Recommended Drain Piping Size]

Model	Fitting Size		Inside Dia. of Pipe
	Japanese Std. "JIS" & European Design Std.	N.American Design Std.	
A3H16 A3H37	1/2 [Inside Dia. 12 mm (.47 in.) or more]	SAE #10	12 mm (.47 in.) or more
A3H56 A3H180	3/4 [Inside Dia. 16 mm (.63 in.) or more]	SAE #12	19 mm (.75 in.) or more

### Safety Valve

When delivery line is blocked suddenly, surge pressure is occurred so a safety valve should be set in the circuit to eliminate any damage on equipment and piping.

### Bleeding Air

It may be necessary to bleed air from pump case and outlet line to remove causes of vibration.

### Starting

Before first starting, fill pump case with clean operating oil via the fill port.

In order to avoid air blockage when first starting, adjust the control valves so that the discharged oil from the pump is returned direct to the tank or the actuator moves in a free load.

[Volume of Pre-fill Oil Required]

Model	Volume cm <sup>3</sup> (in. <sup>3</sup> )
A3H16	400 (24.4)
A3H37	700 (42.7)
A3H56	900 (54.9)
A3H71	1300 (79.3)
A3H100	1700 (104)
A3H145	2400 (146)
A3H180	3200 (195)



**Setting Discharge Pressure and Delivery**

At the time of shipment, the unit has been preset to maximum delivery and minimum discharge pressure. Adjust the preset delivery and pressure to meet your system requirements.

**Adjustment of Discharge Pressure**

Turning the adjustment screw clockwise, increases pressure.

[ Volume adjusted by each full turn of the pressure adjustment screw ]

Model Numbers	Adjustment Volume MPa (PSI)
A3H16/A3H37/A3H56-01	5.5 (780)
A3H71/A3H100/A3H145-01	6.3 (915)
A3H180-01	5.7 (830)

**Adjustment of Delivery**

Turning the flow adjustment screw clockwise, decreases delivery.

[ The minimum adjustable flow and adjustable volume of each full turn of the delivery adjustment screw ]

Model Numbers	Adjustable volume with each full turn of the adjustment screw cm <sup>3</sup> /rev (cu.in./rev)	Minimum adjustment flow cm <sup>3</sup> /rev (cu.in./rev)
A3H16	1.4 (.085)	8 (.488)
A3H37	3.3 (.201)	16 (.976)
A3H56	4.2 (.256)	35 (2.14)
A3H71	4.9 (.299)	45 (2.75)
A3H100	6.2 (.378)	63 (3.84)
A3H145	9.4 (.574)	95 (5.80)
A3H180	10.3 (.629)	125 (7.63)

**Flow Adjustment Screw Protrusion Length "L" vs. Geometric Displacement (reference)**

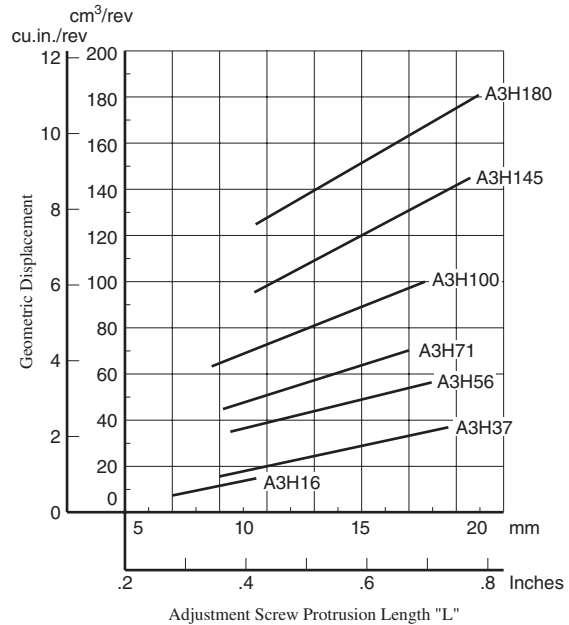
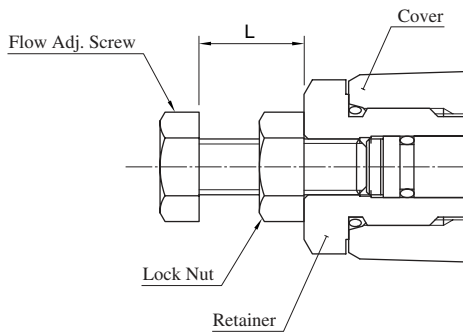

# "A3H" Series Variable Displacement Piston Pumps

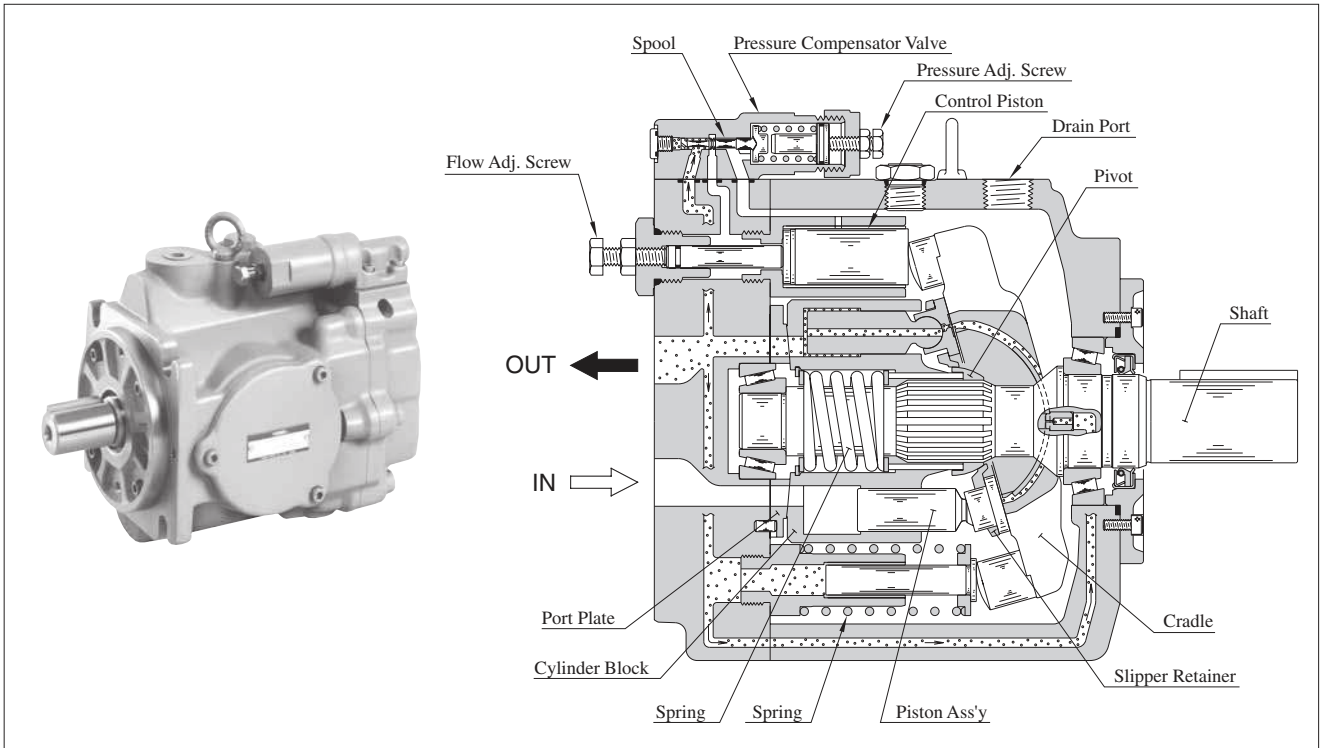

## Control Type

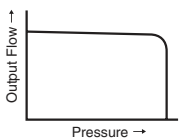
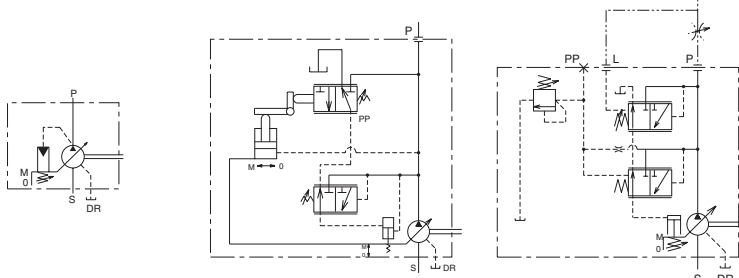
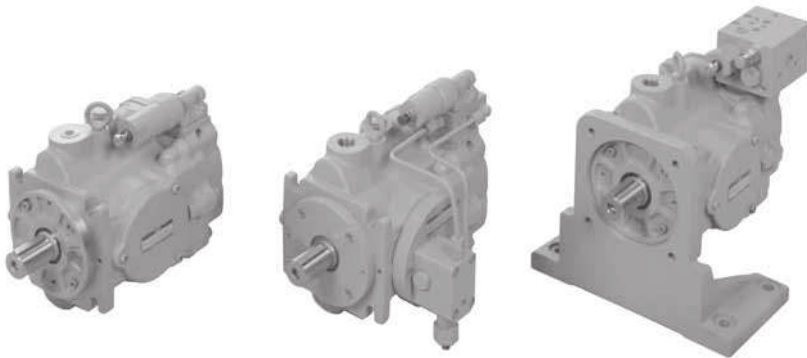

"01" Pressure Compensator Type

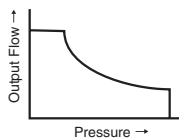

"09" Constant Power Control Type

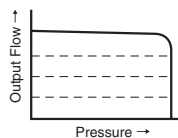

"14" Load Sensing Type

## Features

- **High performance at maximum pressure 35MPa**

Volumetric efficiency is over 95% and overall efficiency is more than 90% at 1800 r/min.

"A3H37" type performance characteristics

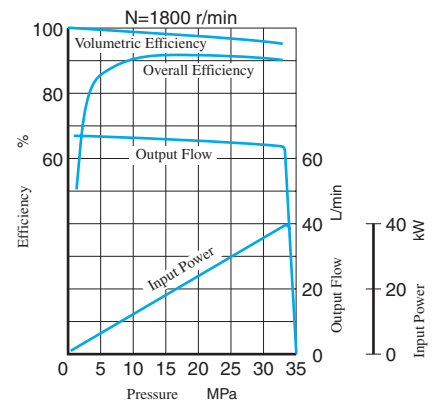

- **Compact size**

A3H series are compact in size because output / mass ratio is large.

Control Type

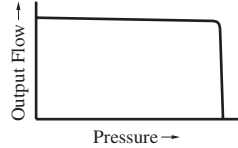
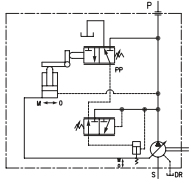
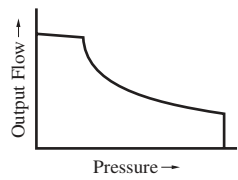
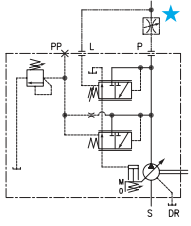
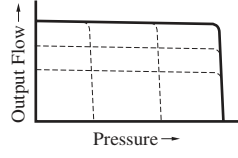
Control Type	Graphic Symbols	Performance Characteristics	Explanation	Page
"01" Pressure Compensator Type			When the system pressure increases and comes close to the preset cut-off pressure, the pump flow decreases automatically while maintaining the set pressure as it is.	122
"09" Constant Power (Torque) Control Type			<ul style="list-style-type: none"> <li>This type of control can control the pump input power according to the motor output.</li> <li>When the system pressure increases, the pump swash plate tilt angle (output flow) decreases, in correspondence to predetermined shaft input values.</li> <li>This type of control can enable one pump to act as two pumps (low-pressure and large-flow/high-pressure and small-flow). Therefore, the motor capacity can be reduced.</li> </ul>	141
"14" Load Sensing Type			<ul style="list-style-type: none"> <li>This is an energy-saving type control which maintains the pump flow and load pressure at the absolute minimum necessary level to operate the actuator.</li> <li>This type of control automatically regulates the output flow so that the inlet-outlet differential pressure of the flow control valve at the output side is constant. To do so, the load pressure must be introduced to the load sensing port "L" of the pump through the external piping.</li> <li>This type of control provides the remote control of the full cut-off pressure by connecting a remote control relief valve to the pilot port "PP".</li> </ul>	150

★ A flow control valve is not included with the pump. Install the valve separately.

Availability of Control Type

Mark "○" in the table below refers to standard model.

Model Numbers	Geometric Displacement cm <sup>3</sup> /rev (cu. in./rev)	"01" Pressure Compensator Type	"09" Constant Power (Torque) Control Type	"14" Load Sensing Type
A3H 16	16.3 (.995)	○		○
A3H 37	37.1 (2.26)	○	○	○
A3H 56	56.3 (3.44)	○	○	○
A3H 71	70.7 (4.31)	○	○	○
A3H100	100.5 (6.13)	○	○	○
A3H145	145.2 (8.86)	○	○	○
A3H180	180.7 (11.03)	○	○	○

## "A3H" Series Variable Displacement Piston Pumps-Single Pump, Pressure Compensator Type

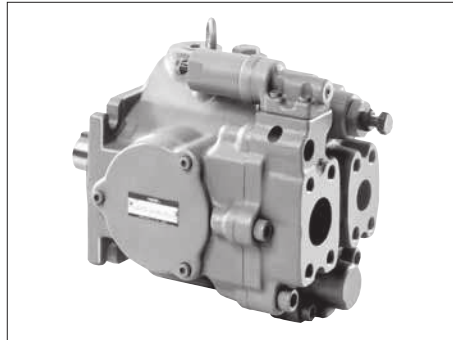

Graphic Symbol

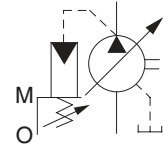

### Specifications

Model Numbers	Geometric Displacement cm <sup>3</sup> /rev (cu.in./rev)	Minimum Adj. Flow cm <sup>3</sup> /rev (cu.in./rev)	Operating Pressure MPa (PSI)		Shaft Speed Range r/min		Approx. Mass kg (lbs.)	
			Rated <sup>*1</sup>	Intermittent	Max. <sup>*2</sup>	Min.	Flange Mtg.	Foot Mtg.
A3H 16-*R01KK-10*	16.3 (.995)	8.0 (.488)	28 (4060)	35 (5080)	3600	600	14.5 (32.0)	23.4 (51.6)
A3H 37-*R01KK-10*	37.1 (2.26)	16.0 (.976)			2700	600	19.5 (43.0)	27.0 (59.5)
A3H 56-*R01KK-10*	56.3 (3.44)	35.0 (2.14)			2500	600	25.7 (56.7)	33.2 (73.2)
A3H 71-*R01KK-10*	70.7 (4.31)	45.0 (2.75)			2300	600	35.0 (77.2)	42.5 (93.7)
A3H100-*R01KK-10*	100.5 (6.13)	63.0 (3.84)			2100	600	44.6 (98.3)	72.6 (160)
A3H145-*R01KK-10*	145.2 (8.86)	95.0 (5.80)			1800	600	60.0 (132)	88.0 (194)
A3H180-*R01KK-10*	180.7 (11.03)	125.0 (7.63)			1800	600	70.4 (155)	98.4 (217)

- ★1. Consult Yuken when pump is used over rated pressure because there is a restriction on operating condition.
- ★2. The maximum shaft speeds shown in the above table are at suction pressure 0 kPa (0 PSIG).
- ★3. The table above shows specifications for using petroleum based oils.  
Pumps (customized design) for special fluids are also available. Their operating pressure and maximum shaft speed however differ from the values in the table above depending on the fluid type.  
Range of operating temperature and viscosities may differ from those of petroleum based oils due to their characteristics.

### Specifications and Design numbers for Special Fluids

Type of Fluids	Operating Pressure MPa (PSI)		Allowable Maximum Shaft Speed r/min		Temperature Range °C (°F)	Viscosity Range mm <sup>2</sup> /s (SSU)	Design Numbers for Special Fluid (Occasion of Japanese Std. "JIS") <sup>*2</sup>
	Rated	Intermittent	Rated	Max.			
Water-Glycols	21 (3050)	21 (3050)	1200	(1800) <sup>*1</sup>	0 - 50 (32 - 104)	20 - 200 (98 - 927)	1030
Phosphate Ester Type	21 (3050)	21 (3050)	1200	(1800) <sup>*1</sup>	0 - 60 (32 - 140)		1006
Polyol Ester Type	21 (3050)	25 (3630)	1200	1800	0 - 60 (32 - 140)	20 - 200 (98 - 927)	10450

- ★1. As the specific gravities of water-glycol fluids and phosphate ester type fluids are higher than one, an overhead reservoir is required when pumps are operated at 1500 r/min or more.
- ★2. For the design numbers of pumps for European Design and North American Design Standards, please contact us.



## Model Number Designation

A3H16	-F	R	01	K	K	-10	*
Series Number	Mounting	Direction of Rotation	Control Type	Pres. Adj. Range MPa (PSI)	Shaft Extension *2	Design Number	Design Std.
<b>A3H16</b> (16.3 cm <sup>3</sup> /rev)	<b>F:</b> Flange Mtg.  <b>L:</b> Foot Mtg.	(Viewed from Shaft End)  <b>R:</b> Clockwise *1 (Normal)	<b>01:</b> Pressure Compensator Type	<b>K:</b> 5 - 35 (725 - 5080)	<b>K :</b> Keyed Shaft	<b>10</b>	Refer to ★3
<b>A3H37</b> (37.1 cm <sup>3</sup> /rev)						<b>10</b>	
<b>A3H56</b> (56.3 cm <sup>3</sup> /rev)						<b>10</b>	
<b>A3H71</b> (70.7 cm <sup>3</sup> /rev)						<b>10</b>	
<b>A3H100</b> (100.5 cm <sup>3</sup> /rev)						<b>10</b>	
<b>A3H145</b> (145.2 cm <sup>3</sup> /rev)						<b>10</b>	
<b>A3H180</b> (180.7 cm <sup>3</sup> /rev)						<b>10</b>	

- ★1. Available to supply pump with anti-clockwise rotation. Consult Yuken for details.
- ★2. We can also supply spline-type shaft extension. Consult Yuken for details.
- ★3. Design Standards: None ..... Japanese Standard "JIS"  
 80 ..... European Design Standard  
 950 ..... N. American Design Standard (Applicable only for A3H16/37/56/71)  
 954 ..... N. American Design Standard (Applicable only for A3H100/145/180)
- ★4. Mounting type "L" is not available for N. American Design Standard.
- ★5. Shaft extension "K1" is applicable only for N. American Design Standard.

## Pipe Flange Kits

Pipe flange kits are available. When ordering, specify the kit number from the table below.

Pump Model Numbers	Name of Port	Threaded Connection			Socket Welding		Butt Welding	
		Japanese Std. "JIS"	European Design Std.	N. American Design Standard	Japanese Std. "JIS" & European Design Std.	N. American Design Standard	Japanese Std. "JIS" & European Design Std.	N. American Design Standard
A3H16-★R01	Suction	F5-08-A-10	F5-08-A-1080	—	F5-08-B-10	F5-08-B-1090	F5-08-C-10	F5-08-C-1090
	Discharge	F6-06-A-M-10 *1	F6-06-A-M-1080	—	F6-06-B-M-10	F6-06-B-U-1090	—	—
A3H37-★R01	Suction	F5-10-A-10	F5-10-A-1080	—	F5-10-B-10	F5-10-B-1090	F5-10-C-10	F5-10-C-1090
	Discharge	F6-08-A-M-10 *1	F6-08-A-M-1080	—	F6-08-B-M-10	F6-08-B-U-1090	—	—
A3H56-★R01	Suction	F5-12-A-10	F5-12-A-1080	—	F5-12-B-10	F5-12-B-1090	F5-12-C-10	F5-12-C-1090
	Discharge	F6-08-A-M-10 *1	F6-08-A-M-1080	—	F6-08-B-M-10	F6-08-B-U-1090	—	—
A3H71-★R01	Suction	F5-16-A-10	F5-16-A-1080	—	F5-16-B-10	F5-16-B-1090	F5-16-C-10	F5-16-C-1090
	Discharge	F6-10-A-M-10 *1	F6-10-A-M-1080	—	F6-10-B-M-10	F6-10-B-U-1090	—	—
A3H100-★R01 A3H145-★R01	Suction	F5-20-A-10	F5-20-A-1080	—	F5-20-B-10	F5-20-B-1090	F5-20-C-10	F5-20-C-1090
	Discharge	F6-10-A-M-10 *1	F6-10-A-M-1080	—	F6-10-B-M-10	F6-10-B-U-1090	—	—
A3H180-★R01	Suction	F5-24-A-10	F5-24-A-1080	—	F5-24-B-10	F5-24-B-1090	—	—
	Discharge	F6-12-A-M-10 *1	F6-12-A-M-1080	—	F6-12-B-M-10	F6-12-B-U-1090	—	—

- ★1. These flanges are with tapered threaded port, maximum pressure is restricted at 31 MPa (4500 PSI).
- ★2. As dimensions of the surface of pipe flanges are conformed to the SAE standards mentioned below, the pipe flanges conforming to the SAE standards can be used.
  - Suction Port: SAE 4 Bolt Split Flange (Standard Pressure Series)
  - Discharge Port: SAE 4 Bolt Split Flange (High Pressure Series)
- Details of pipe flange kits are shown on page 824 & 829.

**Response Characteristics Change in Accordance with Circuits and Operating Conditions.**

● **Test Circuit and Conditions**

● **Circuit**

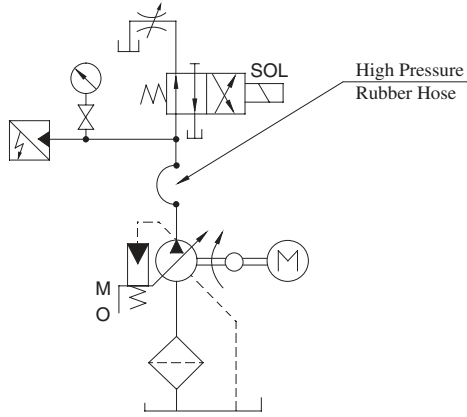

● **Conditions**

Drive Speed: 1500 r/min  
 Hydraulic Fluid: ISO VG32 Oil  
 Oil Temperature: 40 °C (104 °F) [Viscosity 32 mm<sup>2</sup>/s (150 SSU)]

● **Size of High Pressure Rubber House**

Model	High Pressure Rubber Housea
A3H16	3/4B × 1500 mm (4.9 ft.)
A3H37/56/71	3/4B × 2000 mm (6.6 ft.)
A3H100/145	1-1/4B × 2000 mm (6.6 ft.)
A3H180	1-1/4B × 2500 mm (8.2 ft.)

● **Result of Measurement**

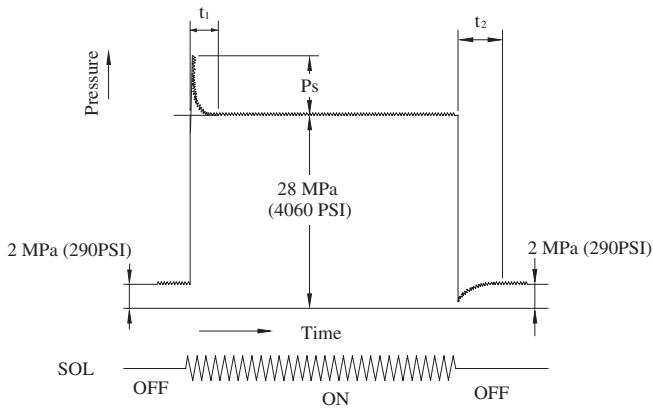

Model	Response Time ms		Ps Overshoot Pres. MPa (PSI)
	$t_1$	$t_2$	
A3H 16	30	140	2.5 (363)
A3H 37	40	80	3.5 (508)
A3H 56	50	90	7.5 (1088)
A3H 71	50	140	10.0 (1450)
A3H100	70	170	11.0 (1595)
A3H145	70	180	12.5 (1813)
A3H180	70	220	12.0 (1740)





Typical Performance Characteristics of Type "A3H16" at Viscosity 32 mm<sup>2</sup>/s (150 SSU) [ISO VG32 oils, 40°C (104°F)]

### Performance Characteristic Curve

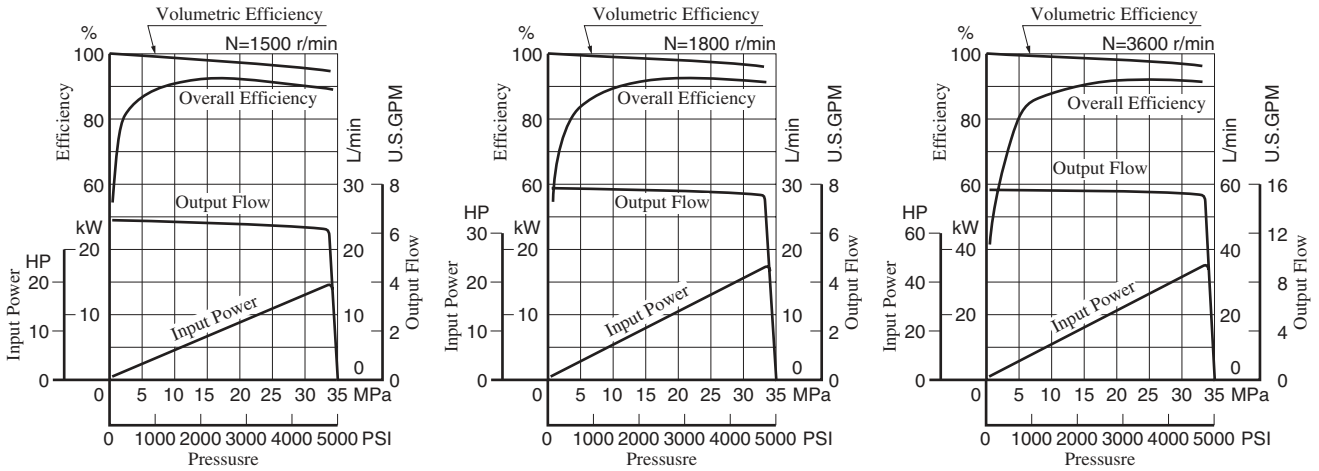

### Input Power

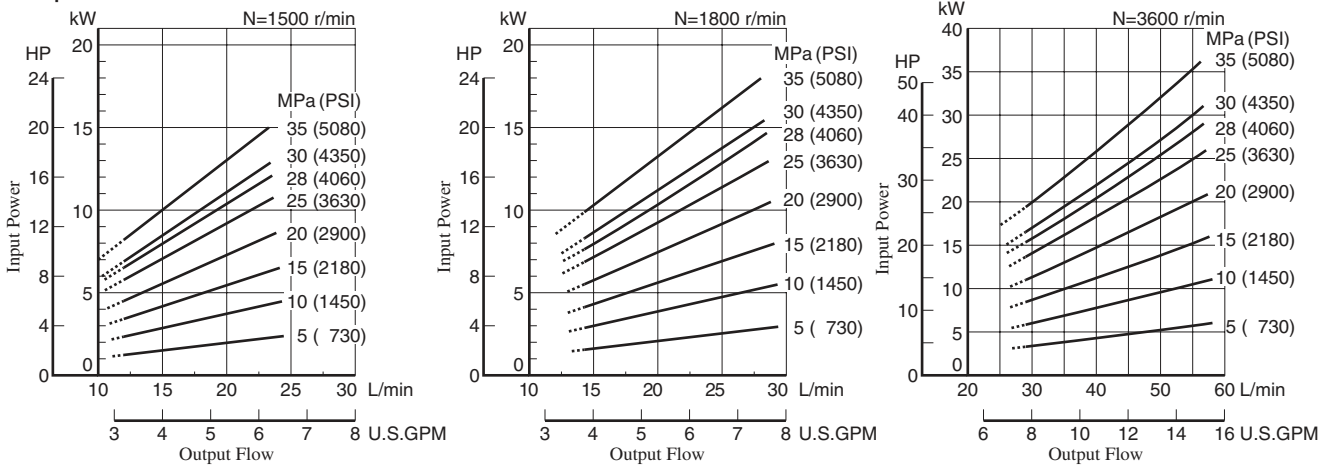

Note) The dotted line in the graph indicates less than minimum adjustable flow.

### Full Cut-off Power

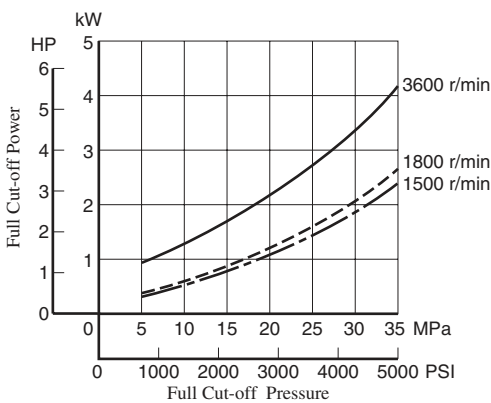

### Drain

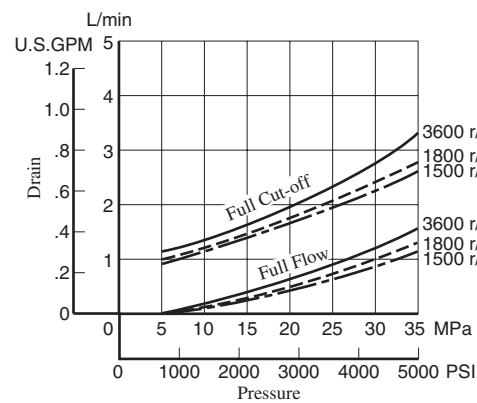

### Noise Level [One metre (3.3 ft.) horizontally away from pump head cover]

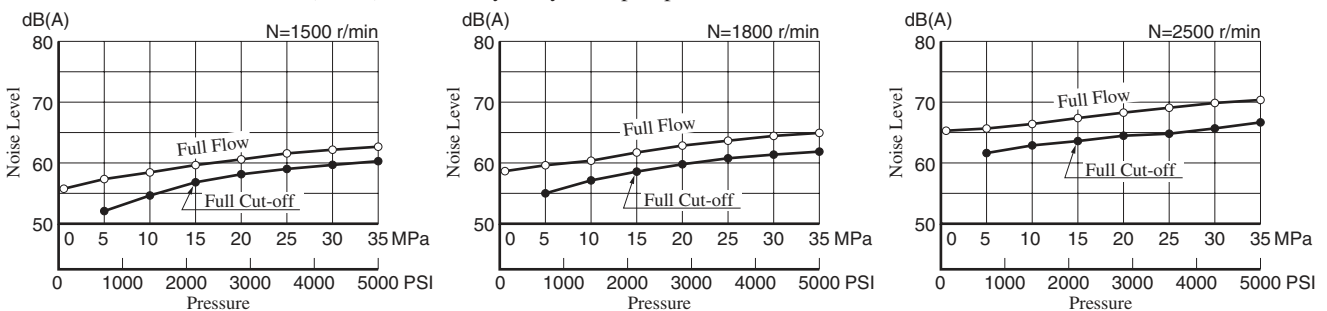

Typical Performance Characteristics of Type "A3H37" at Viscosity 32 mm<sup>2</sup>/s (150 SSU) [ISO VG32 oils, 40°C (104°F)]

**Performance Characteristic Curve**

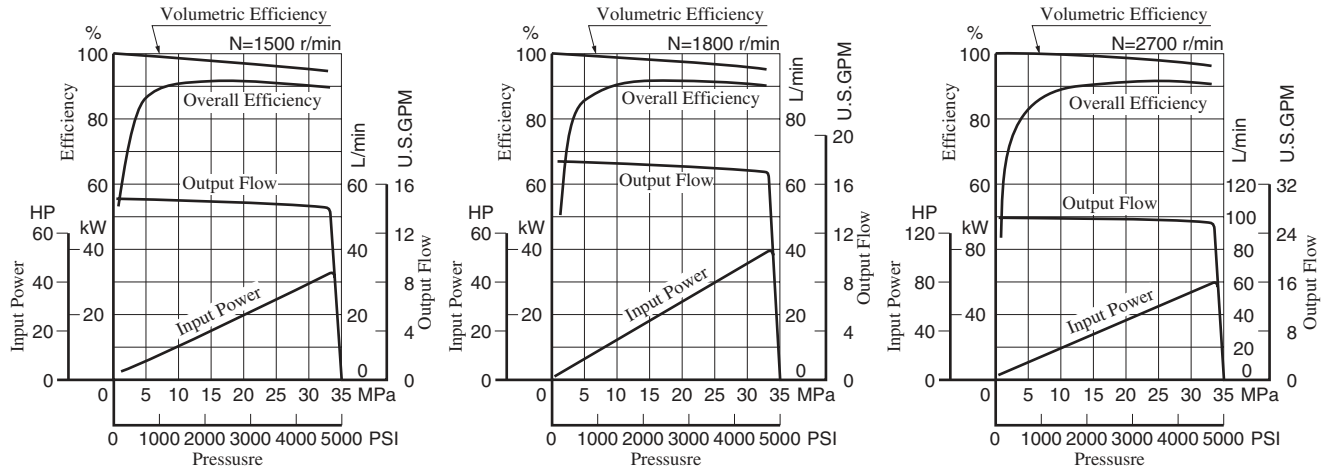

**Input Power**

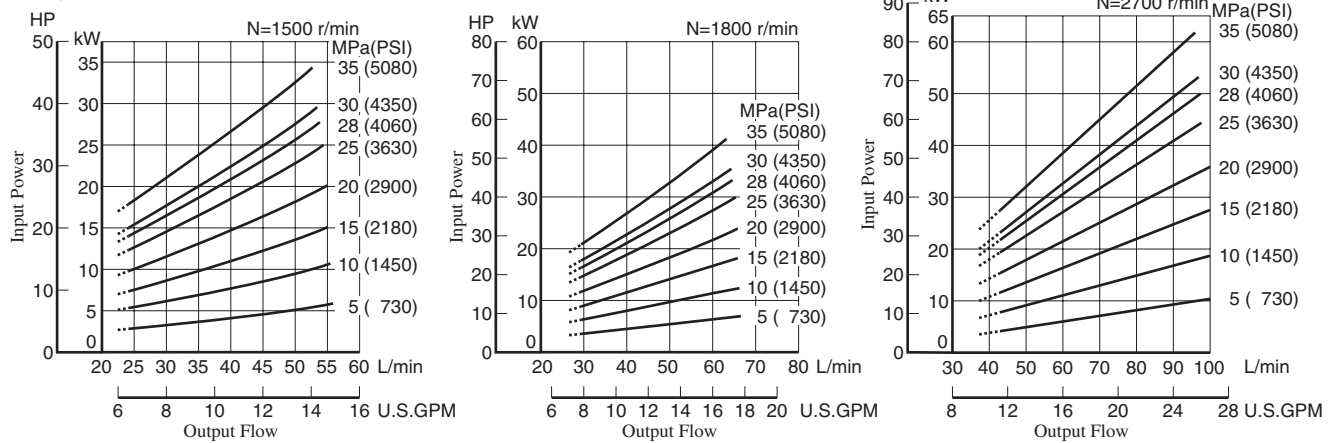

Note) The dotted line in the graph indicates less than minimum adjustable flow.

**Full Cut-off Power**

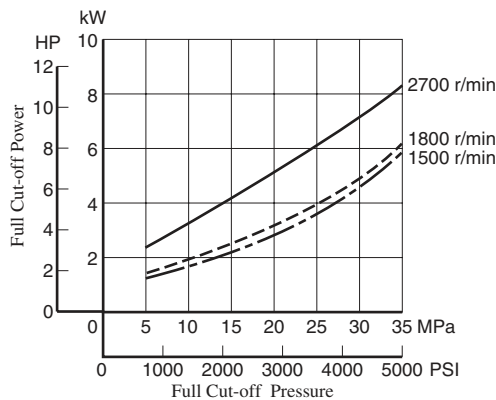

**Drain**

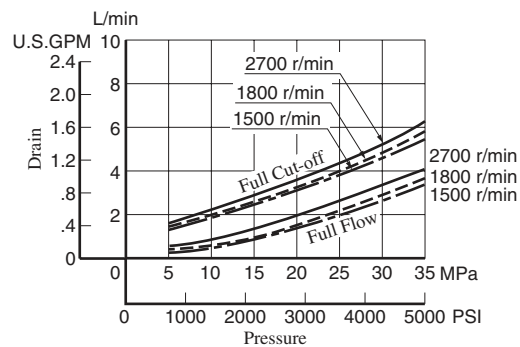

**Noise Level [One metre (3.3 ft.) horizontally away from pump head cover]**

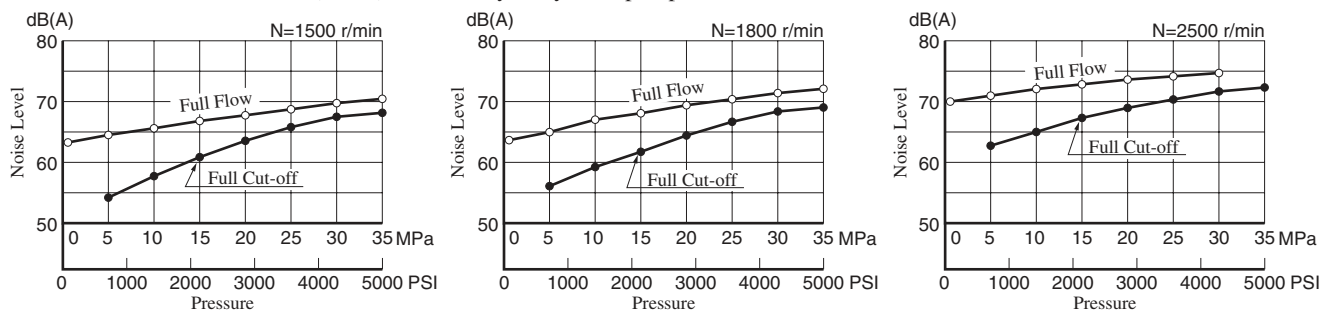

Typical Performance Characteristics of Type "A3H56" at Viscosity 32 mm<sup>2</sup>/s (150 SSU) [ISO VG32 oils, 40°C (104°F)]

## Performance Characteristic Curve

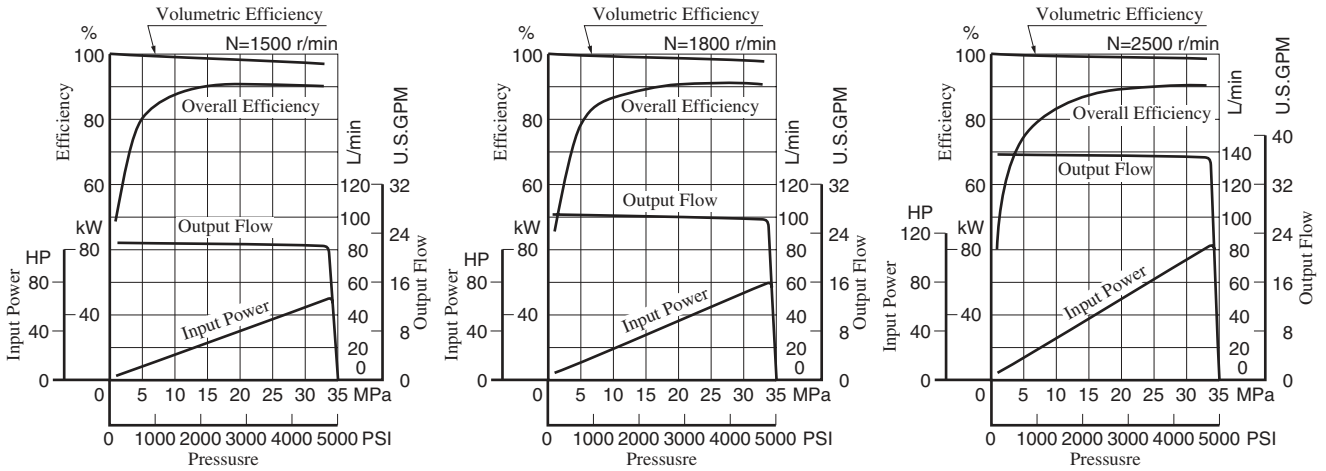

## Input Power

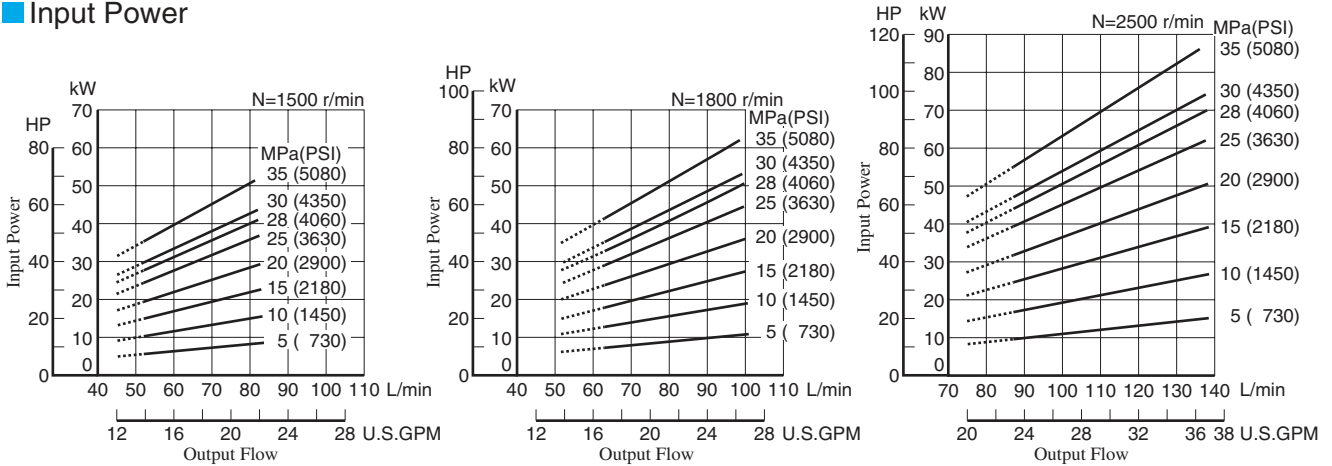

Note) The dotted line in the graph indicates less than minimum adjustable flow.

## Full Cut-off Power

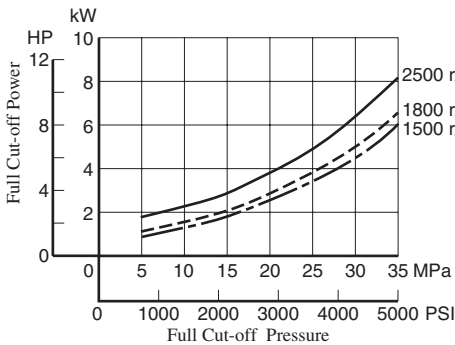

## Drain

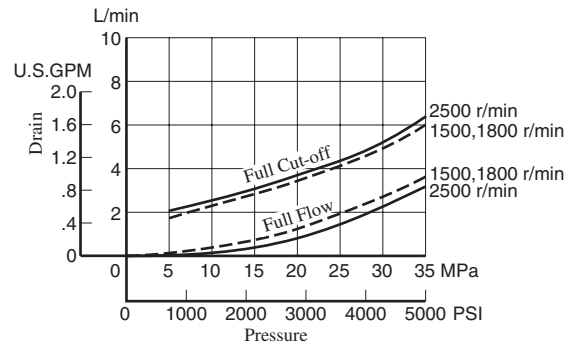

## Noise Level [One metre (3.3 ft.) horizontally away from pump head cover]

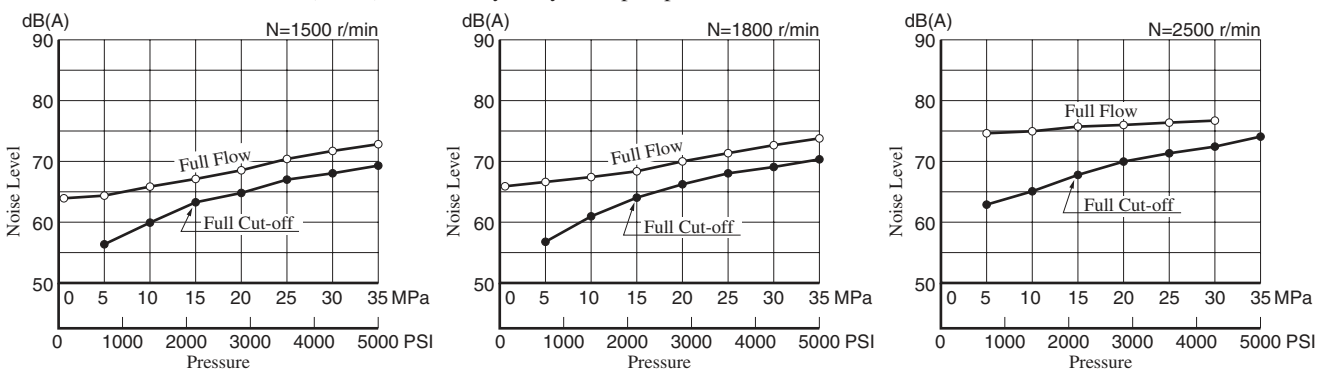

Typical Performance Characteristics of Type "A3H71" at Viscosity 32 mm<sup>2</sup>/s (150 SSU) [ISO VG32 oils, 40°C (104°F)]

**Performance Characteristic Curve**

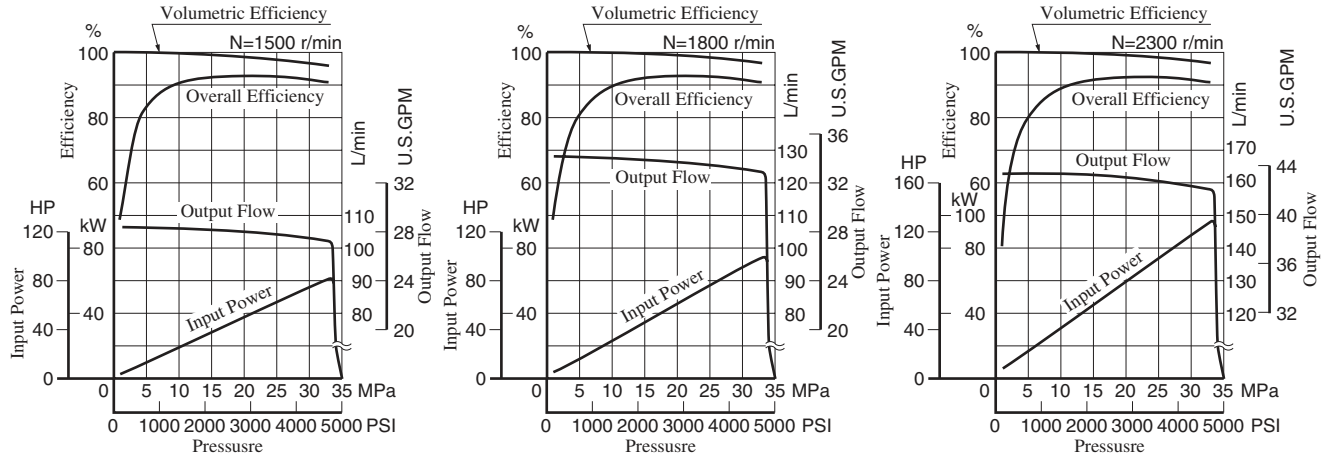

**Input Power**

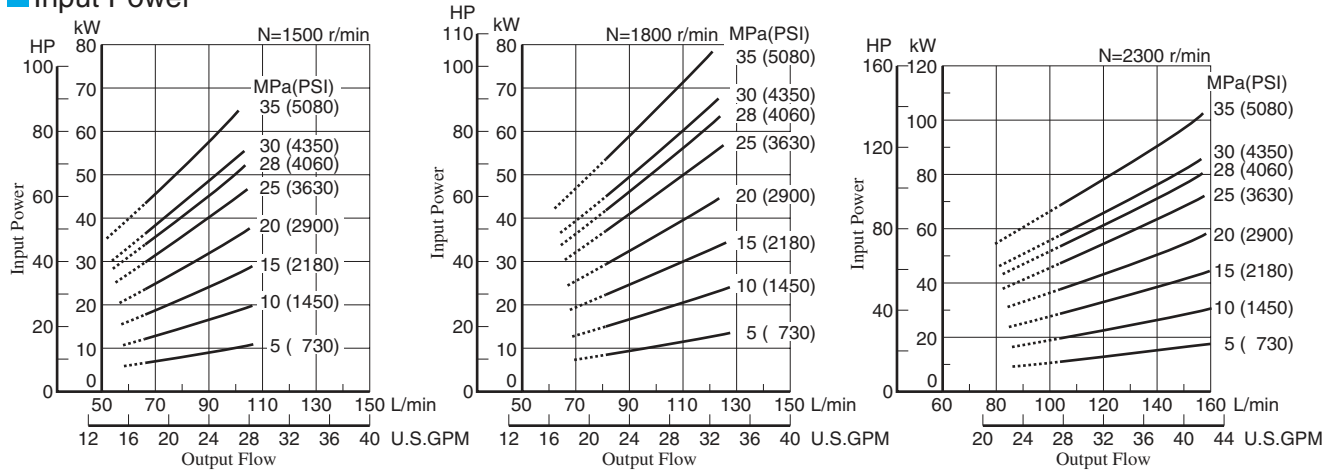

Note) The dotted line in the graph indicates less than minimum adjustable flow.

**Full Cut-off Power**

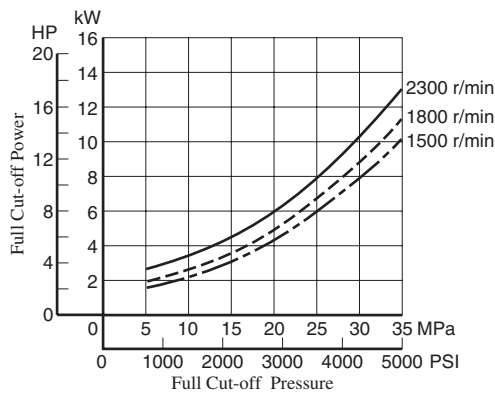

**Drain**

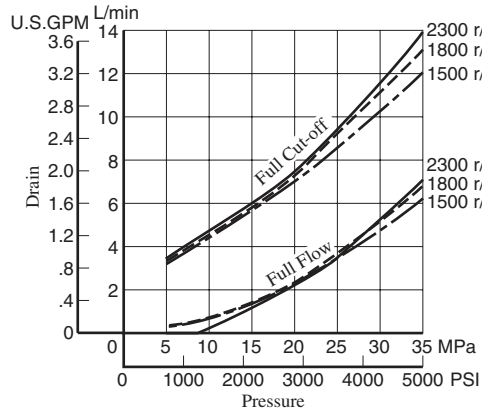

**Noise Level [One metre (3.3 ft.) horizontally away from pump head cover]**

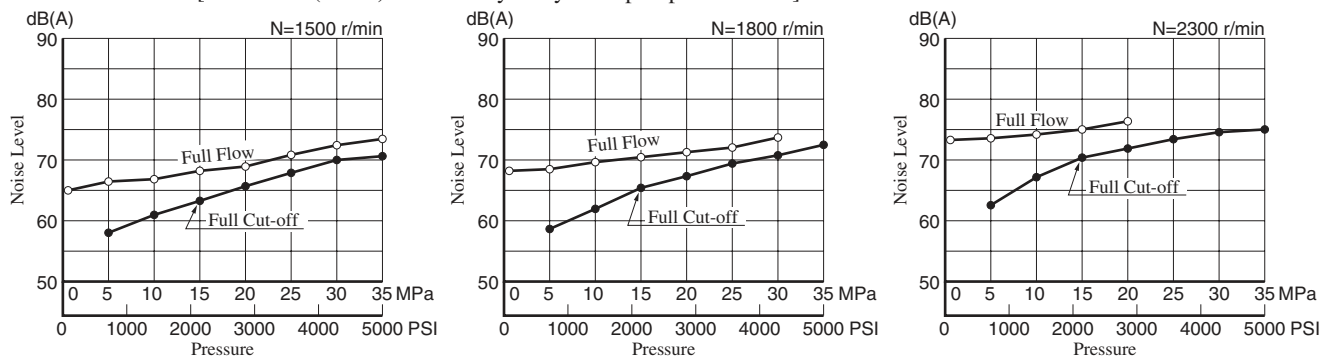



Typical Performance Characteristics of Type "A3H100" at Viscosity 32 mm<sup>2</sup>/s (150 SSU) [ISO VG32 oils, 40°C (104°F)]

### Performance Characteristic Curve

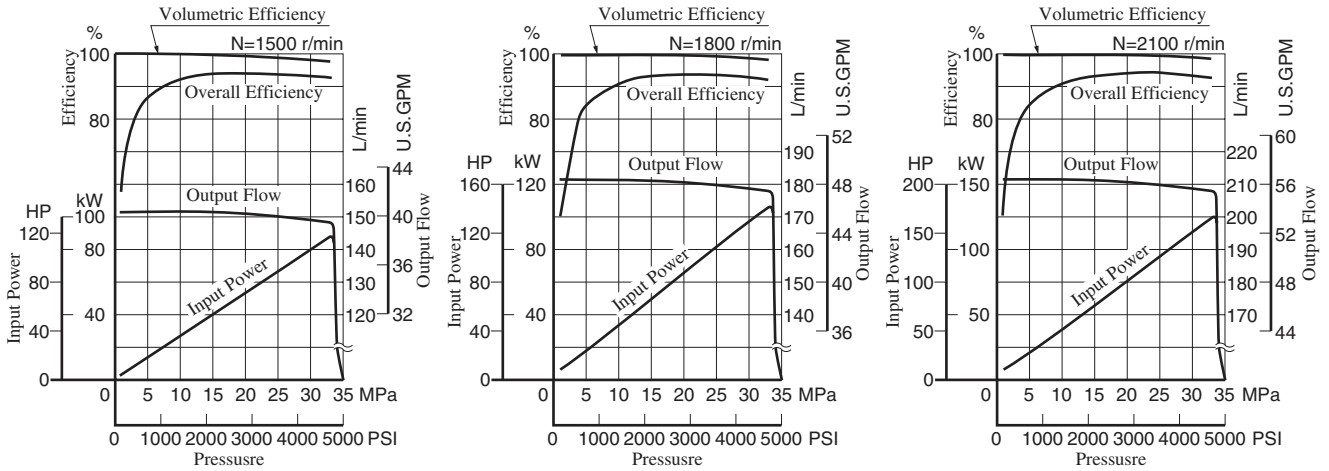

### Input Power

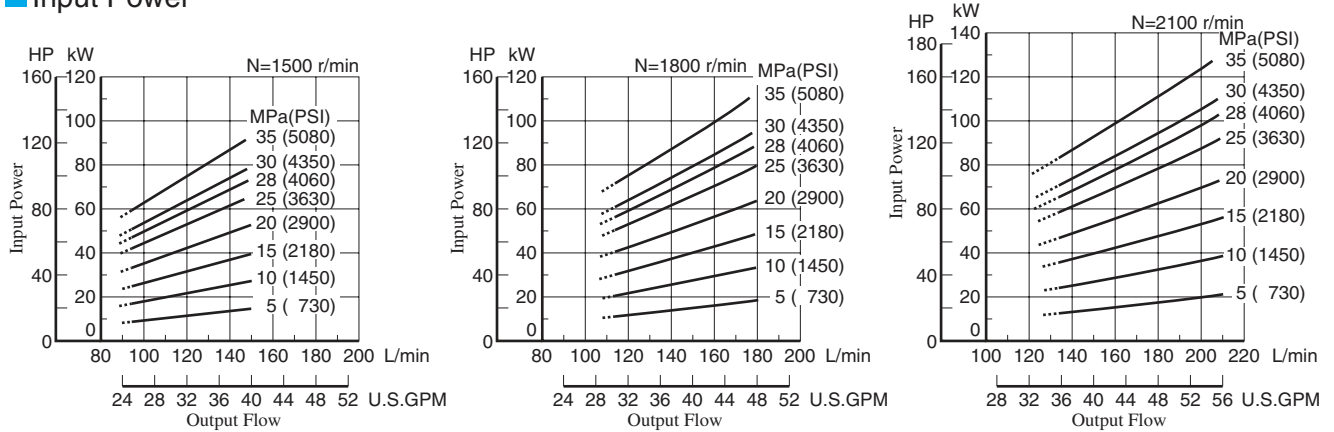

Note) The dotted line in the graph indicates less than minimum adjustable flow.

### Full Cut-off Power

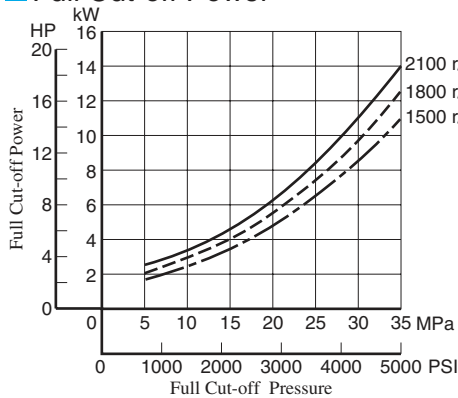

### Drain

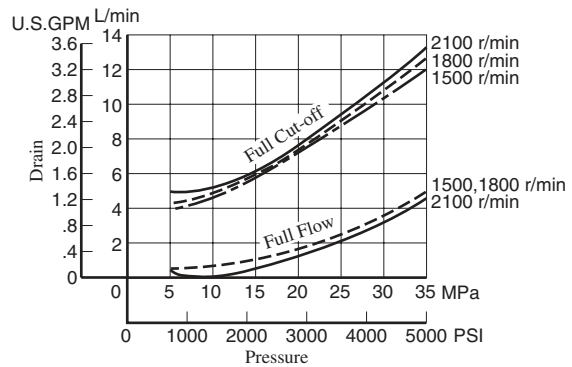

### Noise Level [One metre (3.3 ft.) horizontally away from pump head cover]

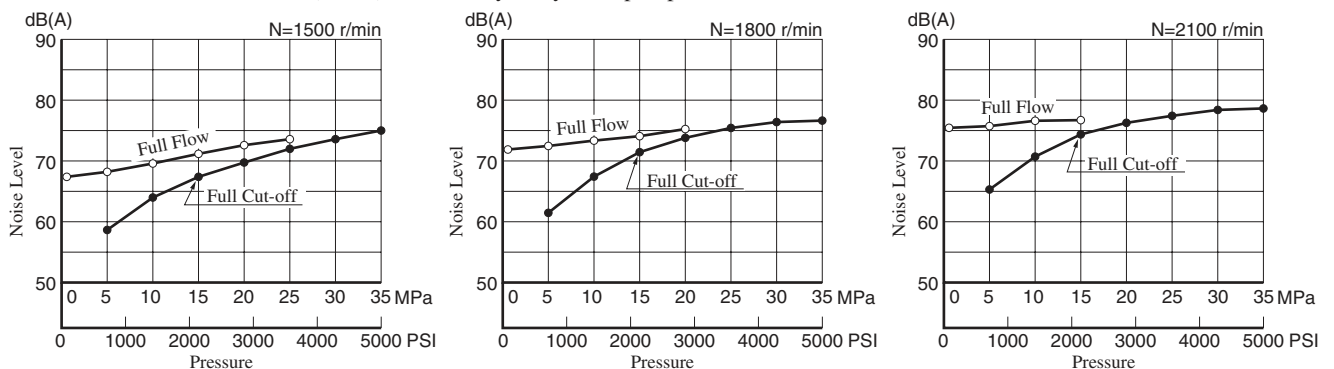

Typical Performance Characteristics of Type "A3H145" at Viscosity 32 mm<sup>2</sup>/s (150 SSU) [ISO VG32 oils, 40°C (104°F)]

**Performance Characteristic Curve**

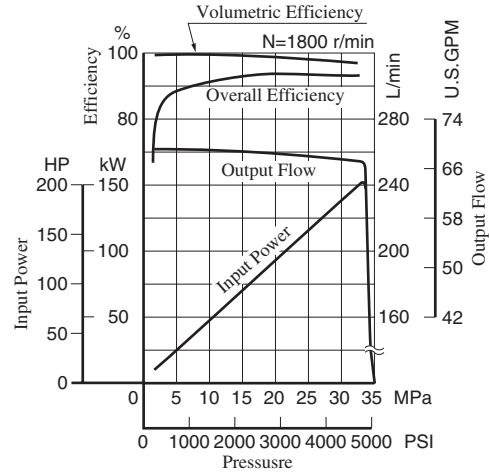
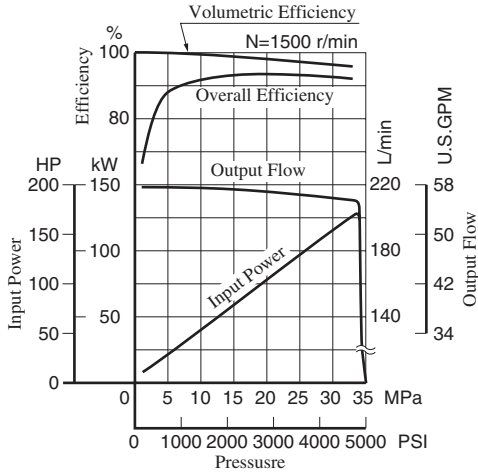

**Input Power**

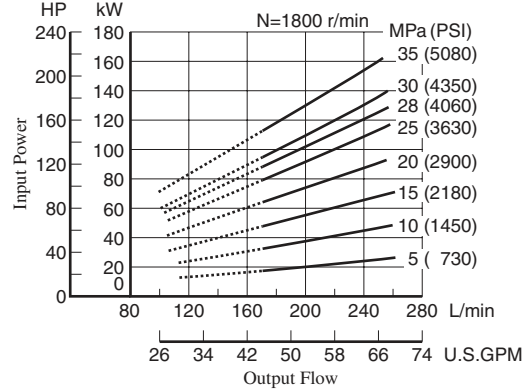
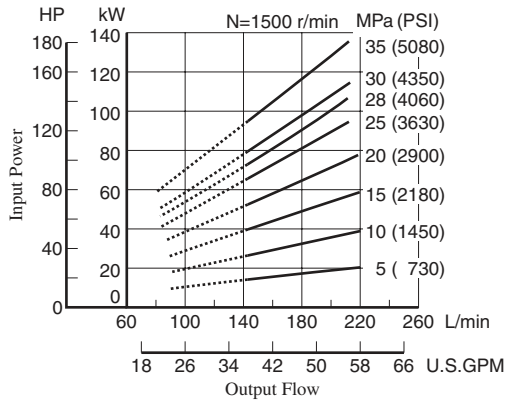

Note) The dotted line in the graph indicates less than minimum adjustable flow.

**Full Cut-off Power**

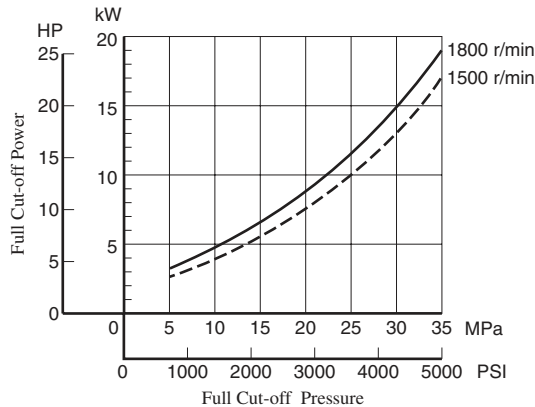

**Drain**

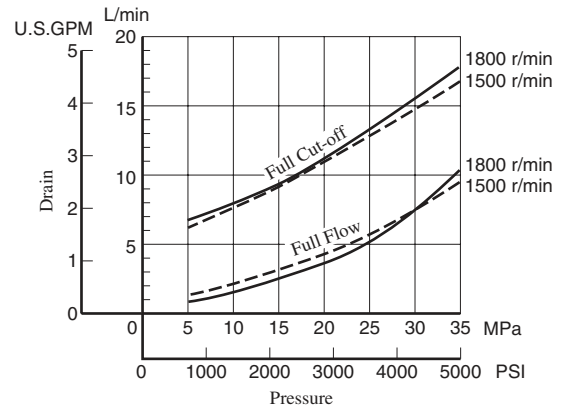

**Noise Level** [One metre (3.3 ft.) horizontally away from pump head cover]

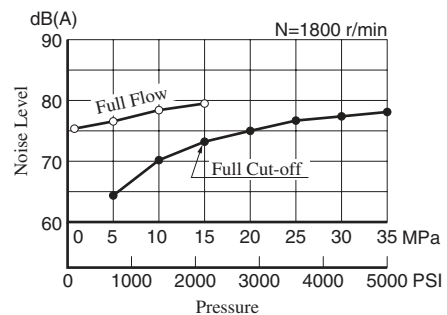
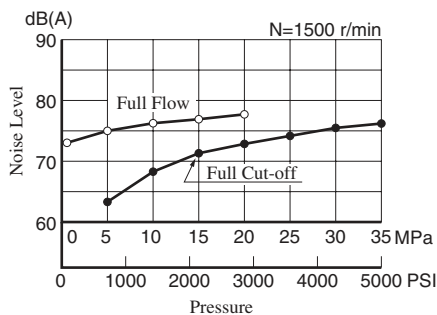

Typical Performance Characteristics of Type "A3H180" at Viscosity 32 mm<sup>2</sup>/s (150 SSU) [ISO VG32 oils, 40°C (104°F)]

### Performance Characteristic Curve

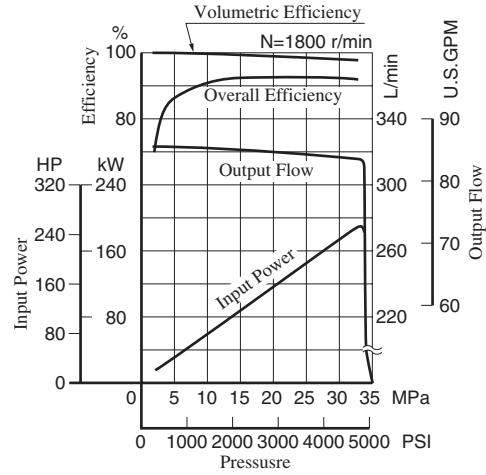
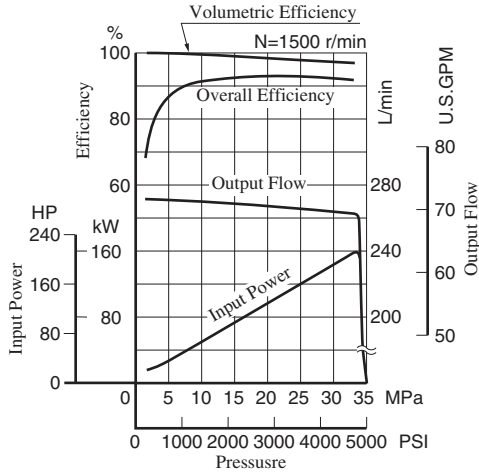

### Input Power

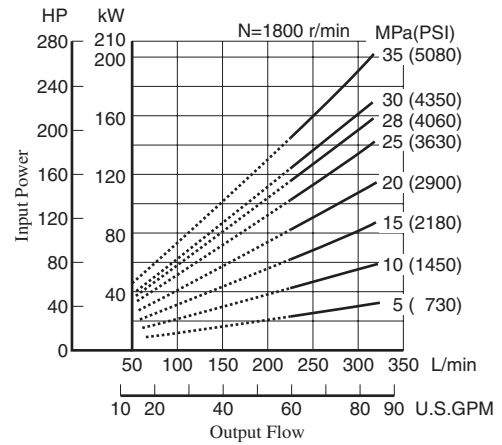
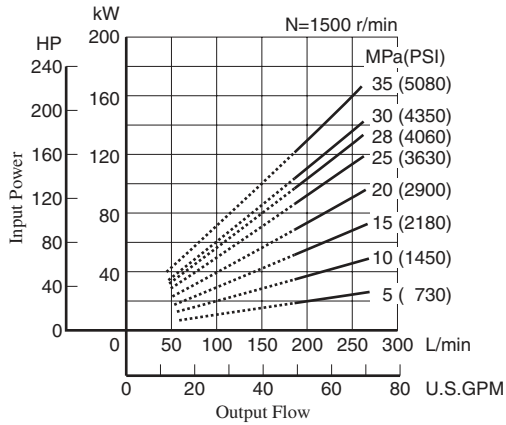

Note) The dotted line in the graph indicates less than minimum adjustable flow.

### Full Cut-off Power

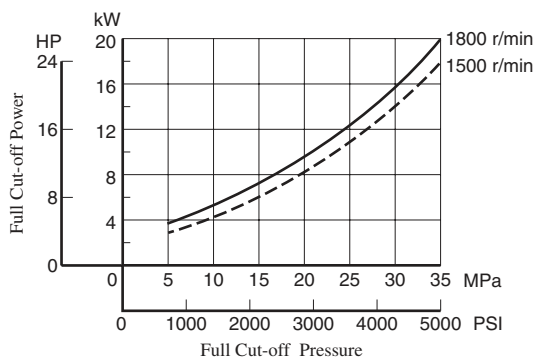

### Drain

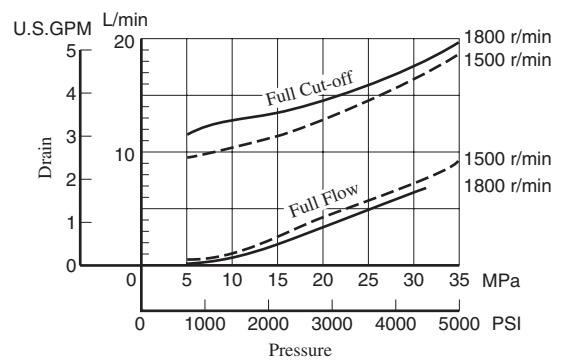

### Noise Level [One metre (3.3 ft.) horizontally away from pump head cover]

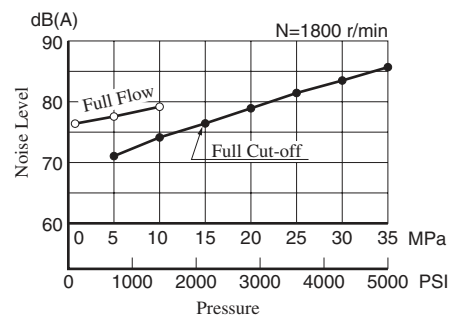
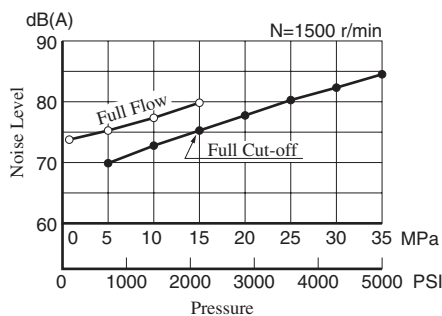

Flange Mtg.: A3H16-FR01KK-10/1080/10950

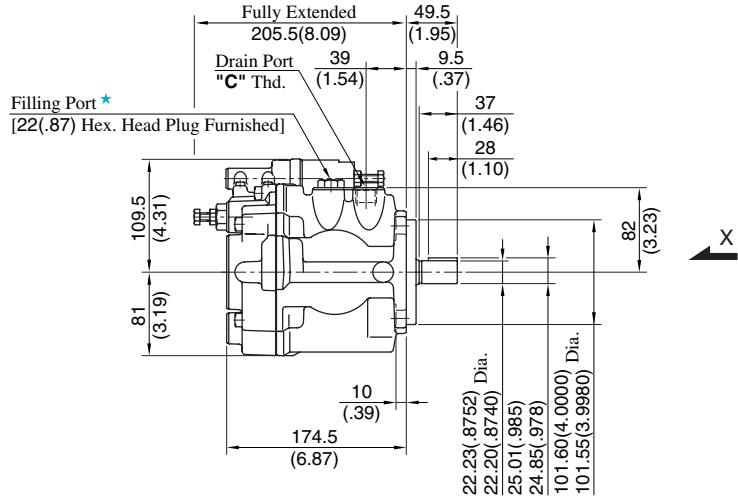
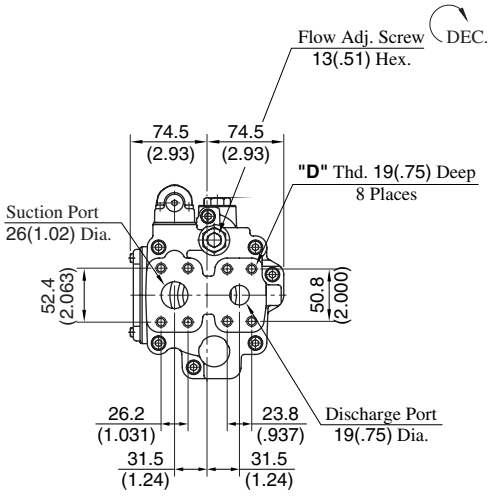

★ Install the pump so that the "Filling port" is at the top.

Model Numbers	"C" Thd.	"D" Thd.
A3H16-FR01KK-10	Rc 1/2	M10
A3H16-FR01KK-1080	1/2 BSP.F	
A3H16-FR01KK-10950	SAE #10	3/8-16 UNC

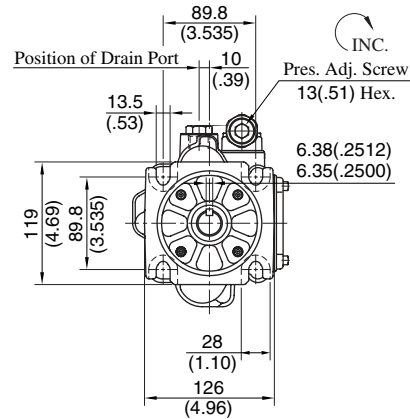

View Arrow X

**DIMENSIONS IN MILLIMETRES (INCHES)**

Foot Mtg.: A3H16-LR01KK-10/1080/10950

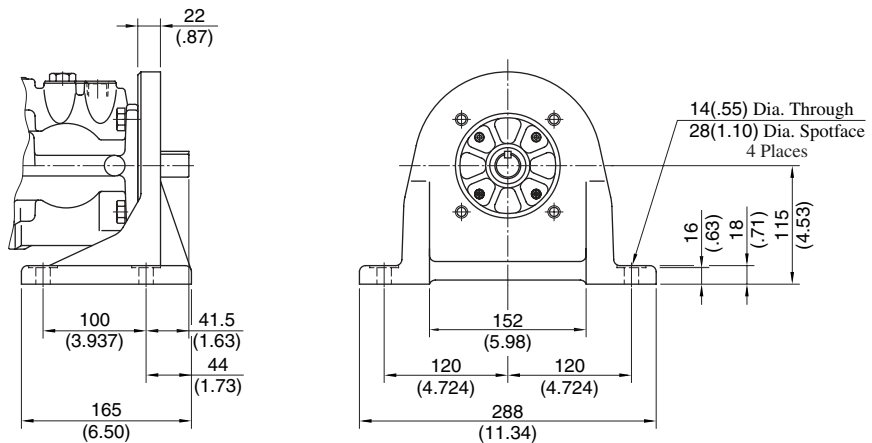

● For other dimensions, refer to "Flange Mtg.".



Flange Mtg.: A3H37-FR01KK-10/1080/10950

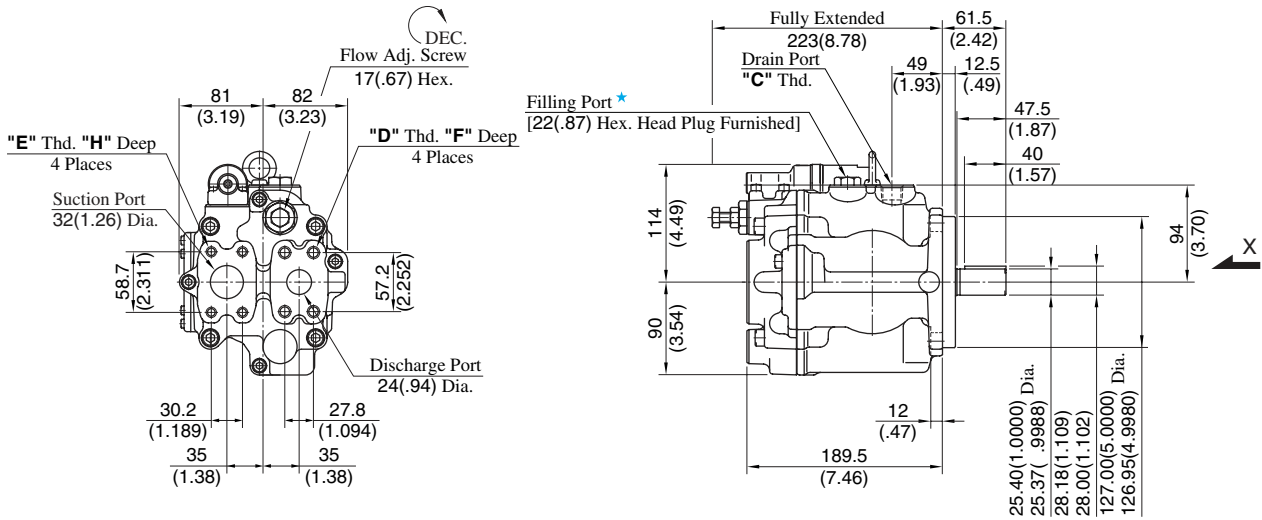

★ Install the pump so that the "Filling port" is at the top.

Model Numbers	"C" Thd.	"D" Thd.	"E" Thd.	F mm(IN.)	H mm(IN.)
A3H37-FR01KK-10	Rc 1/2	M12	M10	22 (.87)	18 (.71)
A3H37-FR01KK-1080	1/2 BSP.F				
A3H37-FR01KK-10950	SAE #10	1/2-13 UNC	7/16-14 UNC	21 (.83)	20 (.79)

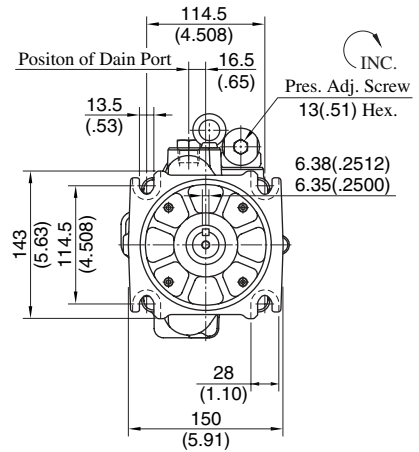

DIMENSIONS IN MILLIMETRES (INCHES)

Foot Mtg.: A3H37-LR01KK-10/1080/10950

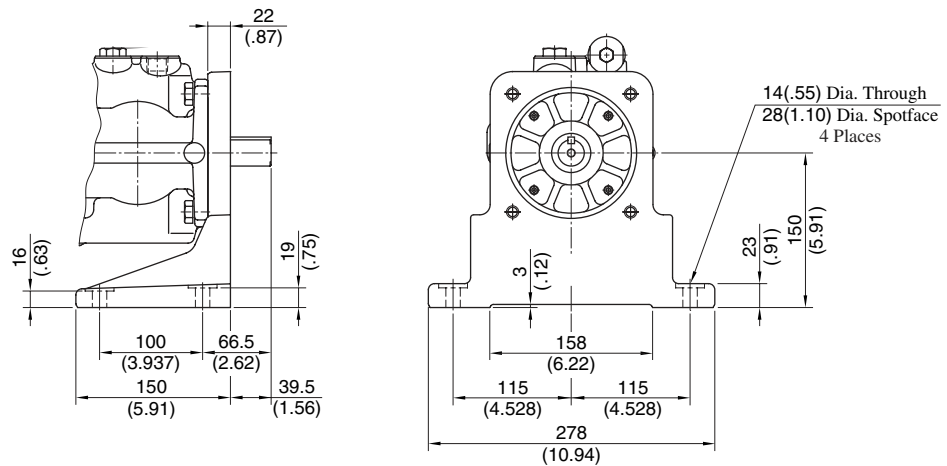

● For other dimensions, refer to "Flange Mtg.".

Flange Mtg.: A3H56-FR01KK-10/1080/10950

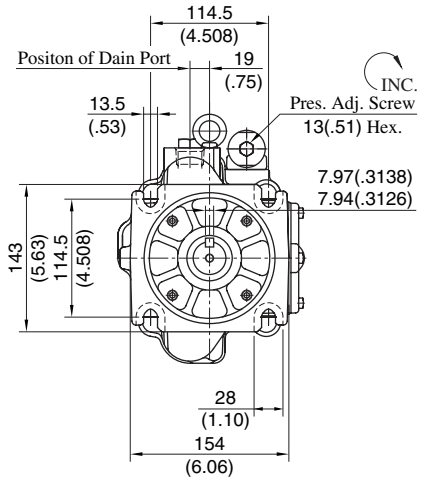
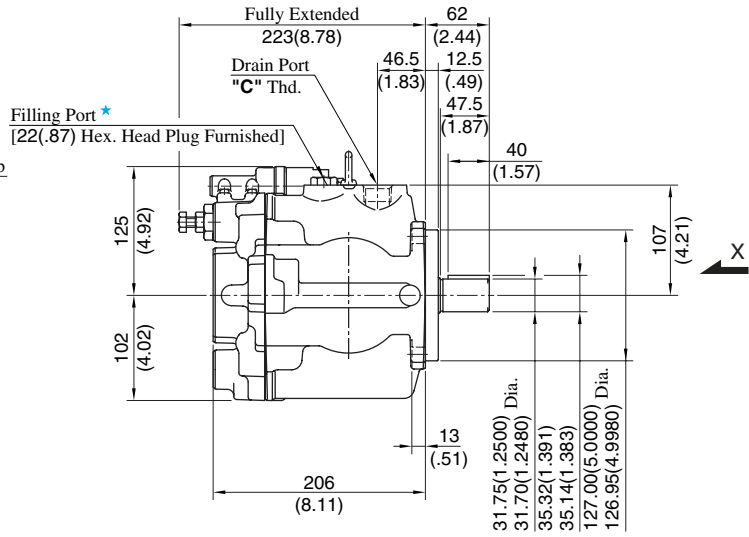
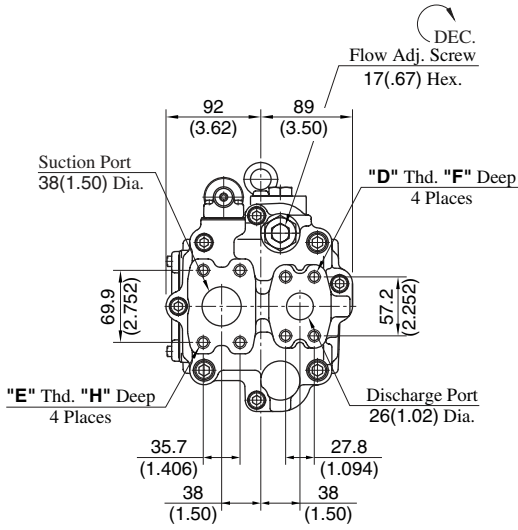

View Arrow X

★ Install the pump so that the "Filling port" is at the top.

Model Numbers	"C" Thd.	"D" Thd.	"E" Thd.	F mm(IN.)	H mm(IN.)
A3H56-FR01KK-10	Rc 3/4	M12	M12	22 (.87)	22 (.87)
A3H56-FR01KK-1080	3/4 BSP.F				
A3H56-FR01KK-10950	SAE #12	1/2-13 UNC	7/16-14 UNC	21 (.83)	20 (.79)

**DIMENSIONS IN MILLIMETRES (INCHES)**

Foot Mtg.: A3H56-LR01KK-10/1080/10950

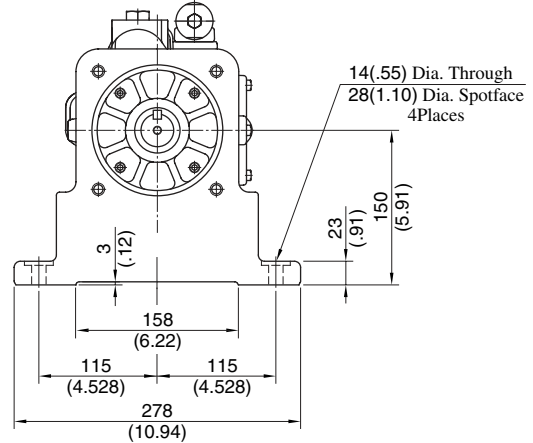
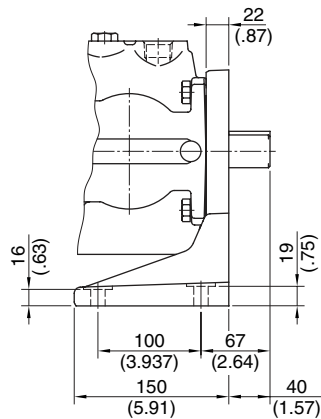

● For other dimensions, refer to "Flange Mtg.".

Flange Mtg.: A3H71-FR01KK-10/1080/10950

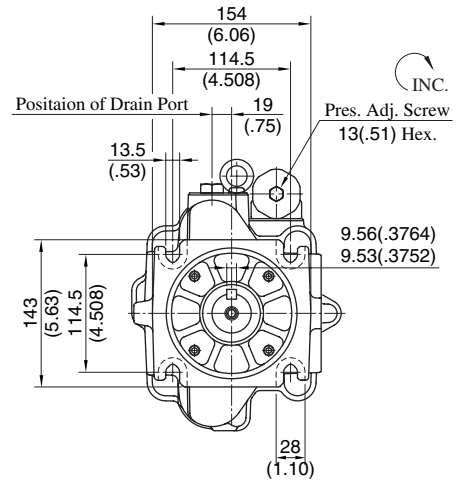
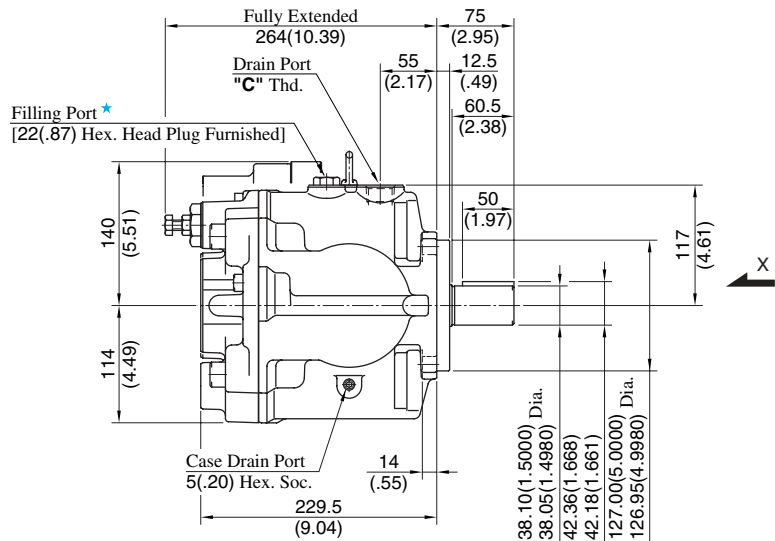
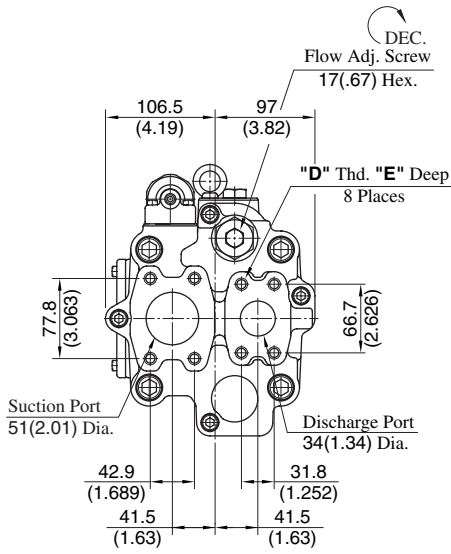

View Arrow X

★ Install the pump so that the "Filling port" is at the top.

Model Numbers	"C" Thd.	"D" Thd.	E mm (IN.)
A3H71-FR01KK-10	Rc 3/4	M12	19 (.75)
A3H71-FR01KK-1080	3/4 BSP.F		
A3H71-FR01KK-10950	SAE #12	1/2-13 UNC	21 (.83)

DIMENSIONS IN MILLIMETRES (INCHES)

Foot Mtg.: A3H71-LR01KK-10/1080/10950

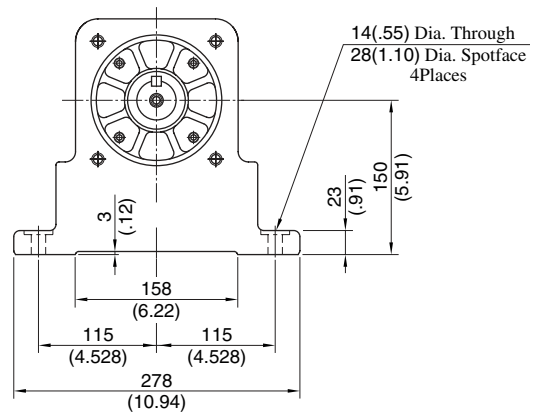
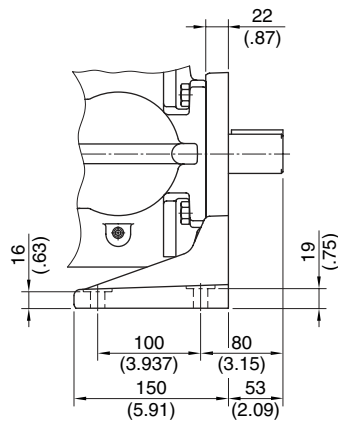

● For other dimensions, refer to "Flange Mtg.".

Flange Mtg.: A3H100-FR01KK-10/1080/10954

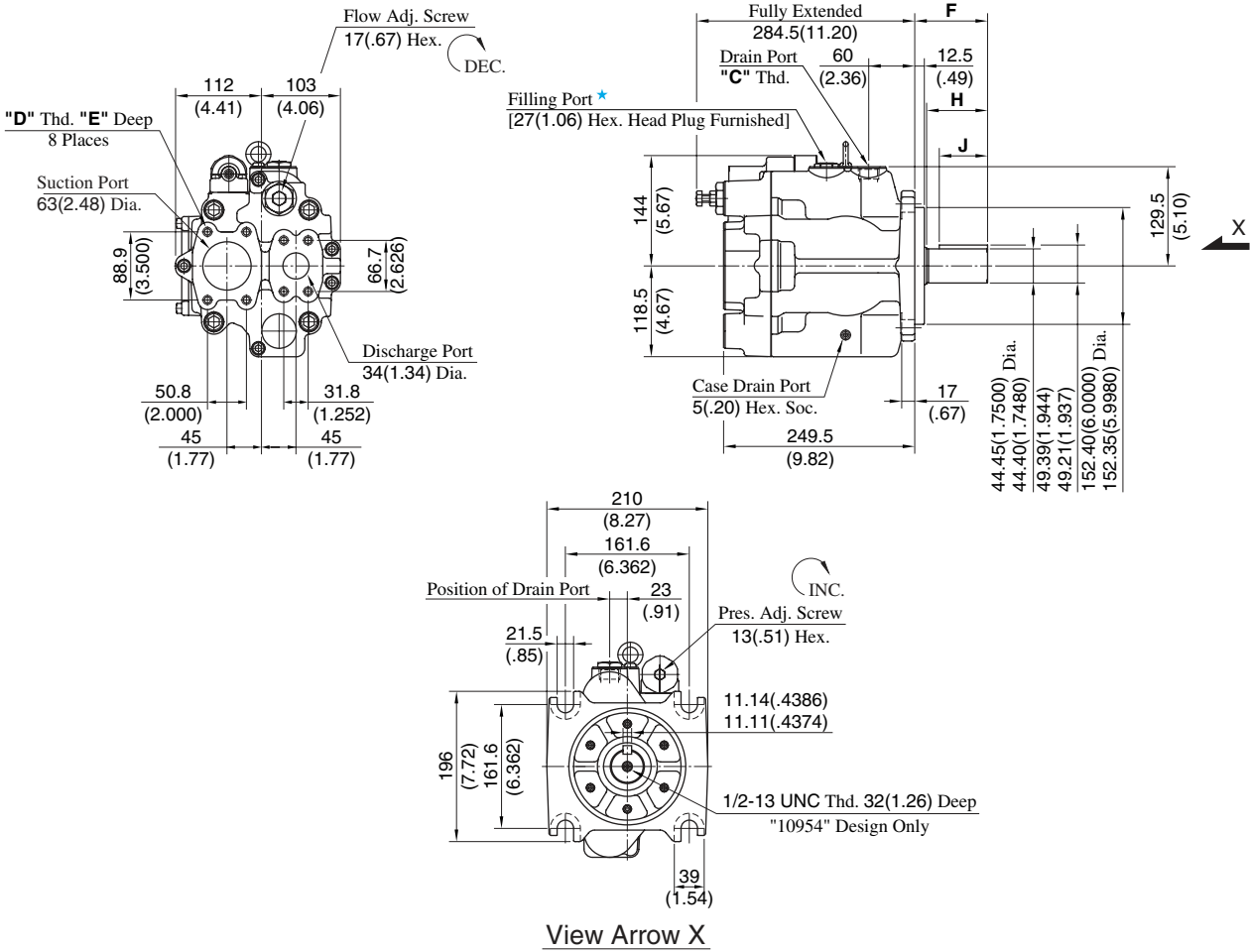

★ Install the pump so that the "Filling port" is at the top.

Model Numbers	Thread Size		Dimensions mm (Inches)			
	C	D	E	F	H	J
A3H100-FR01KK-10	Rc 3/4	M12	19 (.75)	95 (3.74)	81 (3.19)	63 (2.48)
A3H100-FR01KK-1080	3/4 BSP.F					
A3H100-FR01KK-10954	SAE #12	1/2-13 UNC	21 (.83)	74.6 (2.94)	60.6 (2.39)	50 (1.97)

**DIMENSIONS IN MILLIMETRES (INCHES)**

Foot Mtg.: A3H100-LR01KK-10/1080

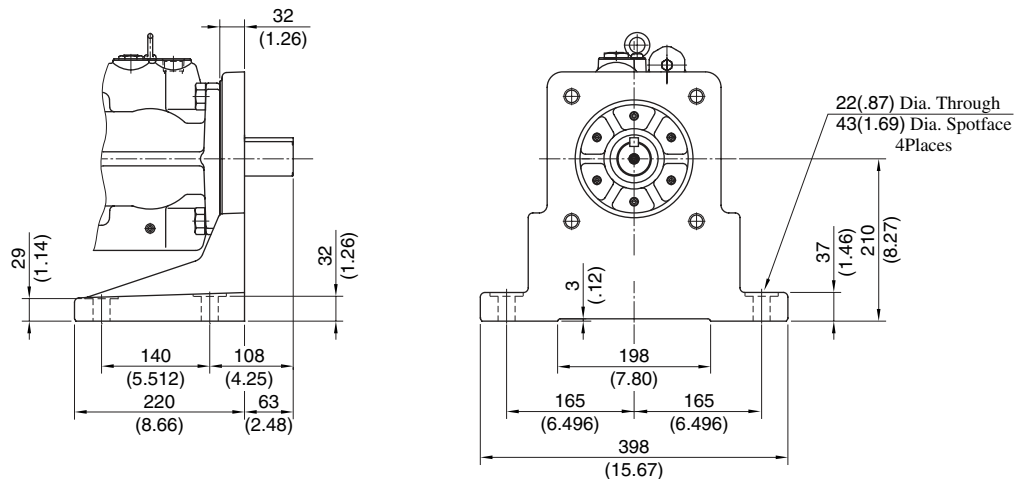

● For other dimensions, refer to "Flange Mtg.".

Flange Mtg.: A3H145-FR01KK\*-10/1080/10954

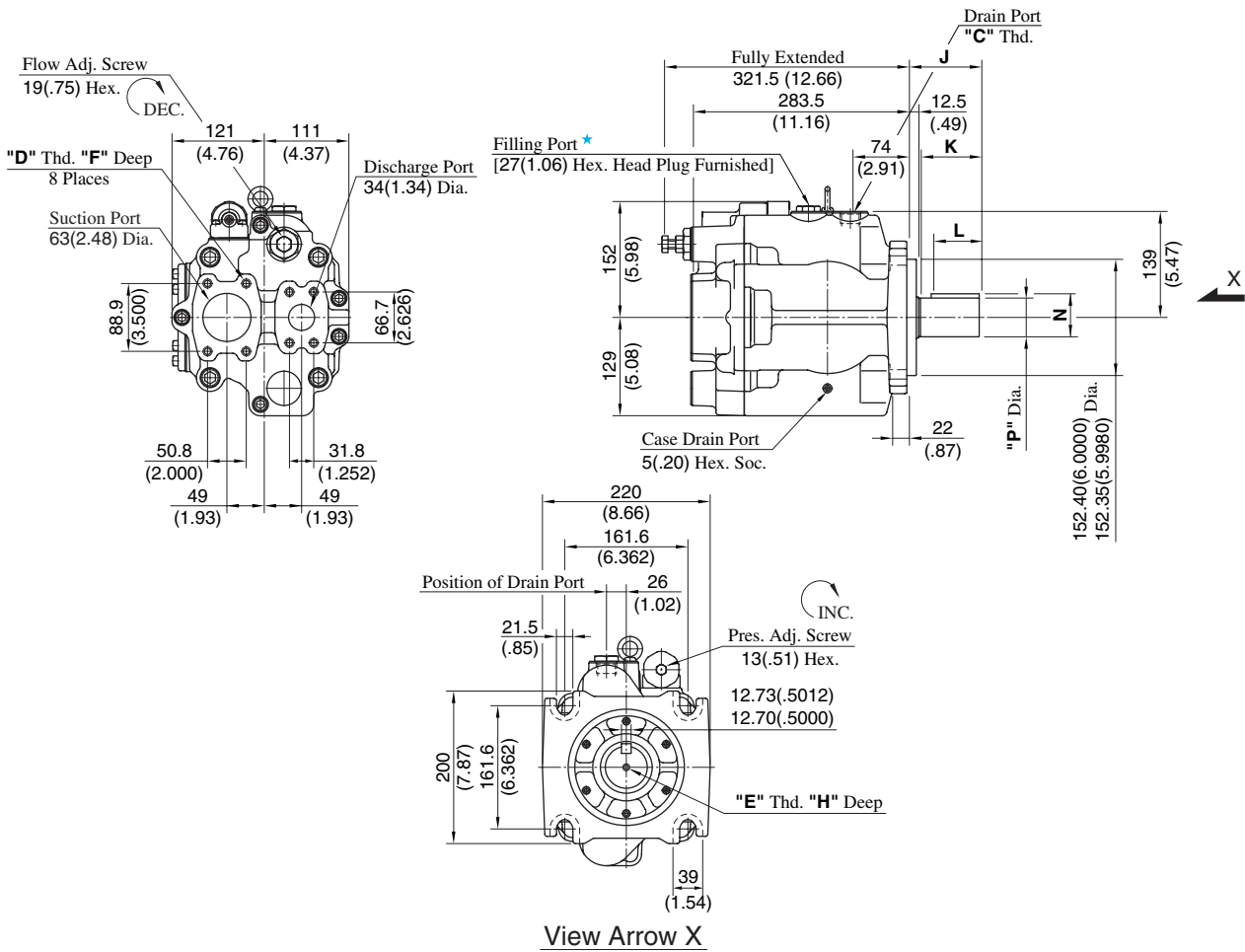

★ Install the pump so that the "Filling port" is at the top.

Model Numbers	Thread Size			Dimensions mm (Inches)						
	C	D	E	F	H	J	K	L	N	P
A3H145-FR01KK-10	Rc 3/4	M12	—	22 (.87)	—	95 (3.74)	81 (3.19)	63 (2.48)	49.39 (1.944)	44.45 (1.7500)
A3H145-FR01KK-1080	3/4 BSP.F								49.21 (1.937)	44.40 (1.7480)
A3H145-FR01KK-10954	SAE #12	1/2-13 UNC	1/2-13 UNC	21 (.83)	32 (1.26)	74.6 (2.94)	60.6 (2.39)	50 (1.97)	49.39 (1.944)	44.45 (1.7500)
A3H145-FR01KK1-10954			5/8-11 UNC						36 (1.42)	56.43 (2.222)
									56.25 (2.215)	50.75 (1.9980)

DIMENSIONS IN MILLIMETRES (INCHES)

Foot Mtg.: A3H145-LR01KK-10/1080

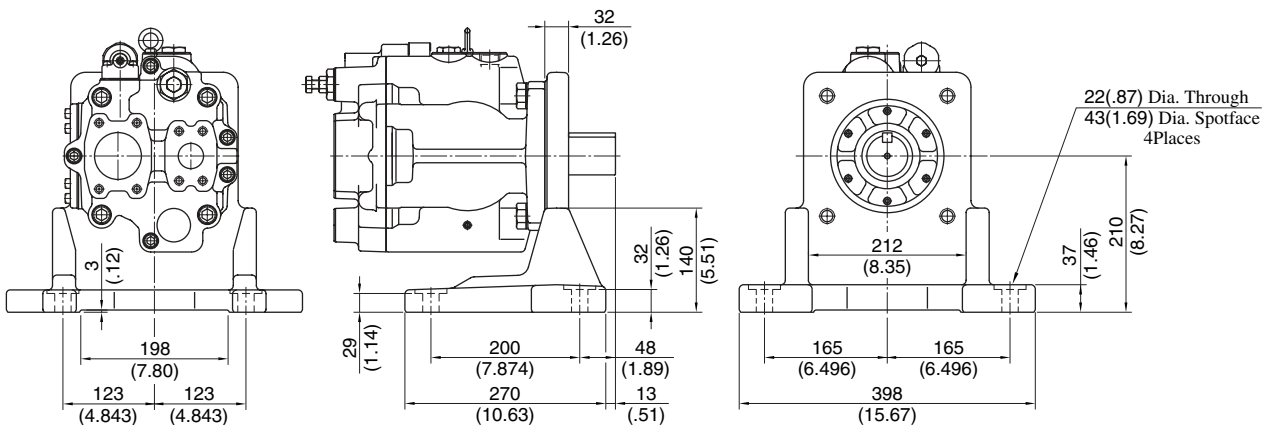

● For other dimensions, refer to "Flange Mtg.".

Flange Mtg.: A3H180-FR01KK\*-10/1080/10954

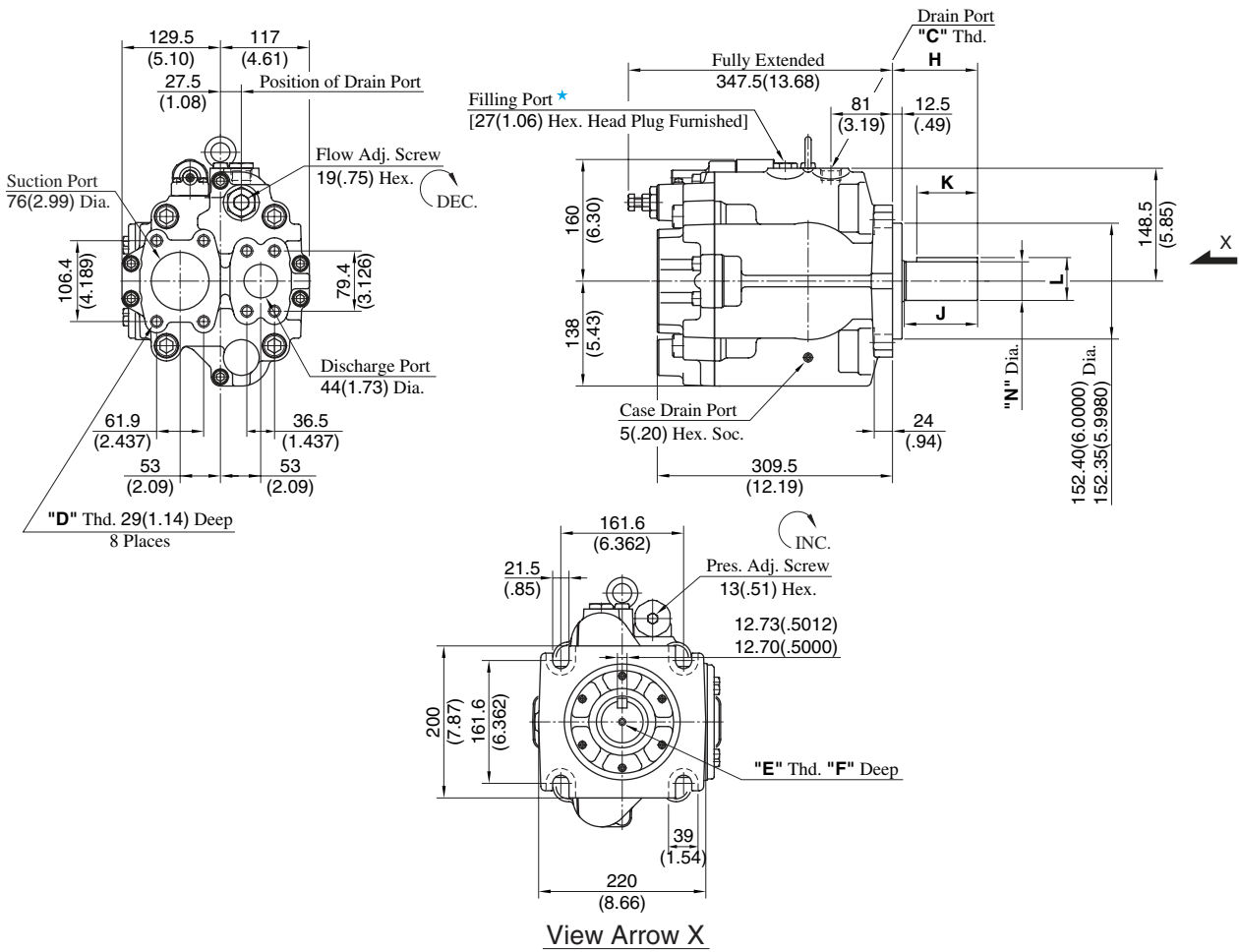

★ Install the pump so that the "Filling port" is at the top.

Model Numbers	Thread Size			Dimensions mm (Inches)						
	C	D	E	F	H	J	K	L	N	
A3H180-FR01KK-10	Rc 3/4	M12	—	—	112 (4.41)	97.5 (3.84)	80 (3.15)	56.43 (2.222)	50.80 (2.0000)	
A3H180-FR01KK-1080	3/4 BSP.F							56.25 (2.215)	50.75 (1.9980)	
A3H180-FR01KK-10954	SAE #12	5/8-11 UNC	1/2-13 UNC	32 (1.26)	74.6 (2.94)	60.6 (2.39)	50 (1.97)	49.39 (1.944)	44.45 (1.7500)	
A3H180-FR01KK1-10954			5/8-11 UNC	36 (1.42)				56.43 (2.222)	50.80 (2.0000)	
								56.25 (2.215)	50.75 (1.9980)	

**DIMENSIONS IN MILLIMETRES (INCHES)**

Foot Mtg.: A3H180-LR01KK-10/1080

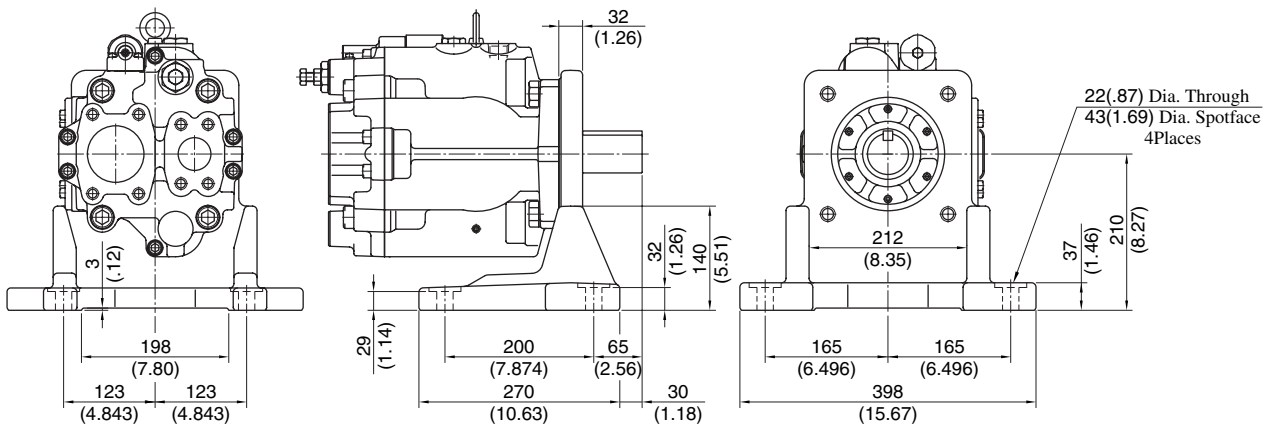

● For other dimensions, refer to "Flange Mtg.".

Spear Parts List

A3H16/A3H37/A3H56-\*R01KK-10/1080/10950

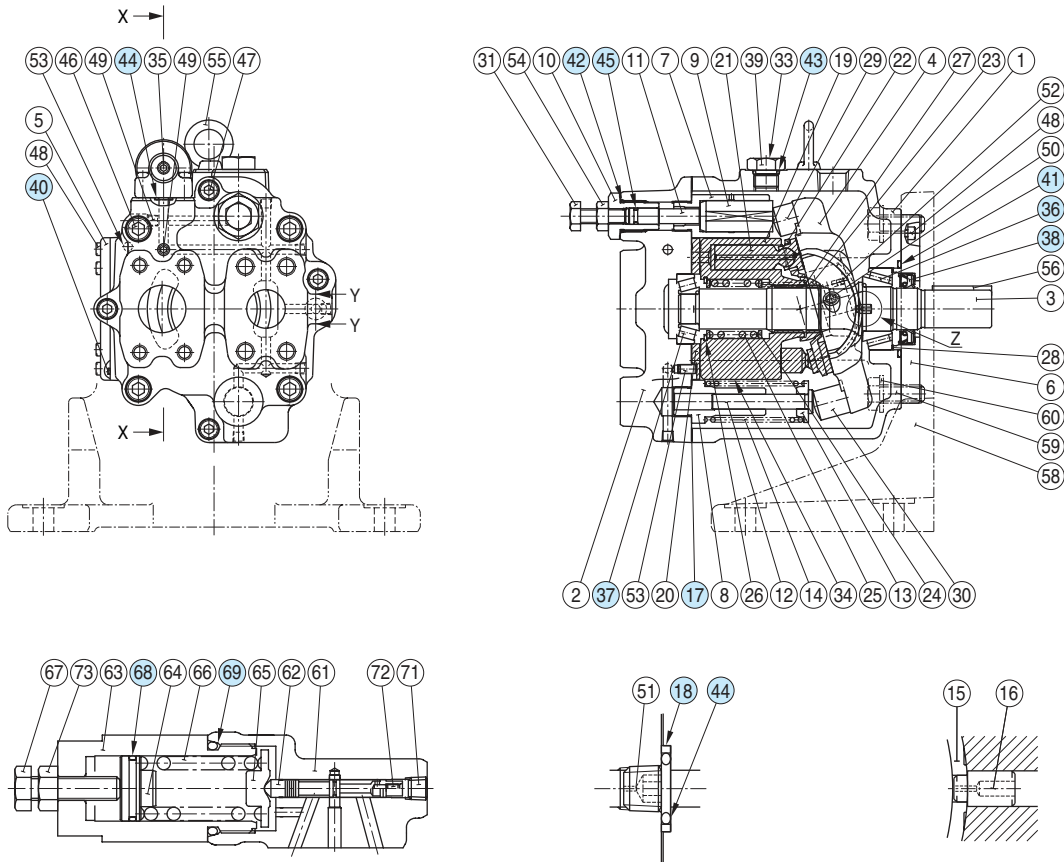

Detail of Section X – X

Detail of Section Y – Y

Detail of "Z"

List of Seals and Bearings

Item	Name of Parts	Part Numbers			Q'ty.
		A3H16	A3H37	A3H56	
17*	Gasket	2270-PK313655-3	2271-PK-313518-3	2272-PK313433-5	1
18*	Back Up Ring	1310E-PK412440-0			1
36	Cylindrical Roller Bearing	NUP205E	—	—	1
	Tapered Roller Bearing	—	4T-30204	4T-33008	
37	Needle Roller Bearing	HMK2025V2	—	—	1
	Tapered Roller Bearing	—	4T-33006	4T-32205R	
38*	Oil Seal	TCN254511 (FKM)	TCN284811 (FKM)	TCN355511 (FKM)	1
40*	O-Ring	S65 (NBR, Hs70)	S85 (NBR, Hs70)	S95 (NBR, Hs70)	1
41*	O-Ring	SO-NA-G60	SO-NA-G60	S71 (NBR, Hs70)	1
42*	O-Ring	SO-NB-P14	SO-NB-P18	SO-NB-P21	1
43*	O-Ring	SO-NB-P14			1
44*	O-Ring	SO-NB-P9			4
45*	O-Ring	SO-NB-P6	SO-NB-P8	SO-NB-P9	1
68*	O-Ring	SO-NA-A018			1
69*	O-Ring	SO-NB-P26			1

\* When ordering seals, please specify the kit number from the table below.

List of Seals kit

Pump Model Numbers	Seal Kit Numbers
A3H16-*R01KK-10/1080/10950	A3H16-01-10
A3H37-*R01KK-10/1080/10950	A3H37-01-10
A3H56-*R01KK-10/1080/10950	A3H56-01-10

**Spear Parts List**

A3H71-\*R01KK-10/1080/10950  
 A3H100/A3H145/A3H180-\*R01KK\*-10/1080/10954

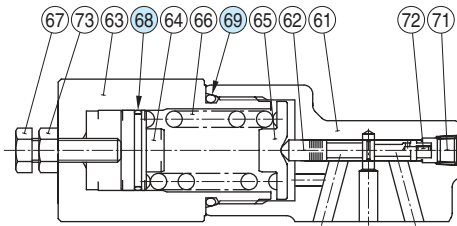
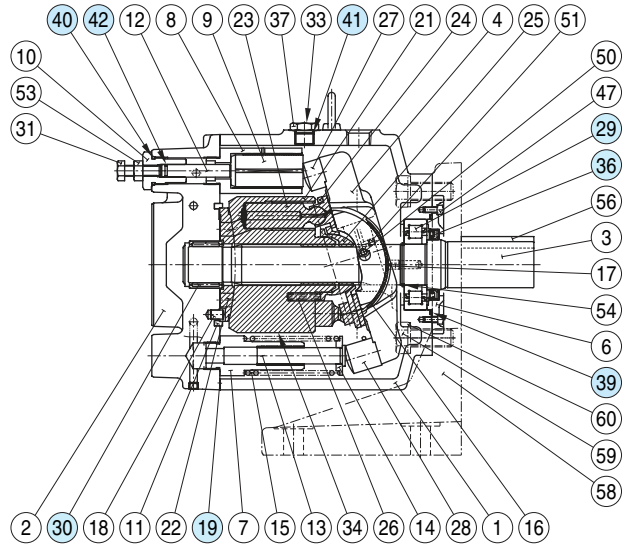
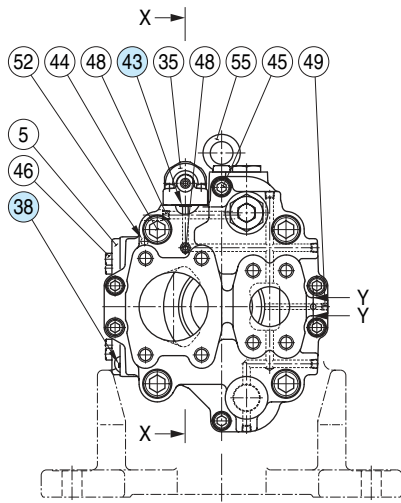

Detail of Section X – X

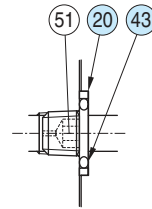

Detail of Section Y – Y

**List of Seals and Bearings**

Item	Name of Parts	Part Numbers				Q'ty.
		A3H71	A3H100	A3H145	A3H180	
19*	Gasket	2273-PK212356-0	2274-PK212368-5	2275-PK212382-6	2276-PK212301-6	1
20*	Back Up Ring	1310E-PK412440-0				1
29	Tapered Roller Bearing	33009JR	4T-33206	HR33011	—	1
	Cylindrical Roller Bearing	—	—	—	2276-PK412859-1	
30	Tapered Roller Bearing	32205JR	4T-30210	4T-33206	—	1
	Needle Roller Bearing	—	—	—	2276-PK412860-9	
36*	Oil Seal	TCN426512 (FKM)	TCN507212 (FKM)	TCN557812 (FKM)	TCN557812 (FKM)	1
38*	O-Ring	S100 (NBR, Hs70)	S110 (NBR, Hs70)	S125 (NBR, Hs70)	S130 (NBR, Hs70)	1
39*	O-Ring	SO-NA-G80	SO-NA-G95	SO-NA-G95	SO-NA-G105	1
40*	O-Ring	SO-NB-P24		SO-NB-P26		1
41*	O-Ring	SO-NB-P14	SO-NB-P18	SO-NB-P18		1
42*	O-Ring	SO-NB-P9			SO-NB-P10A	1
43*	O-Ring	SO-NB-P9				4
68*	O-Ring	SO-NA-A021				1
69*	O-Ring	SO-NB-P32				1

\* When ordering seals, please specify the kit number from the table below.

**List of Seals kit**

Pump Model Numbers	Seal Kit Numbers
A3H71-*R01KK-10/1080/10950	A3H71-01-10
A3H100-*R01KK-10/1080/10954	A3H100-01-10
A3H145-*R01KK-10/1080/10954	A3H145-01-10
A3H180-*R01KK-10/1080/10954	A3H180-01-10





# "A3H" Series Variable Displacement Piston Pumps-Single Pump, Constant Power (Torque) Control Type

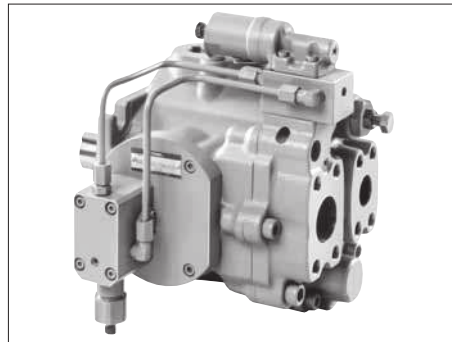

Graphic Symbol

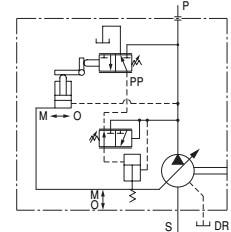

## Specifications

Model Numbers	Geometric Displacement cm <sup>3</sup> /rev (cu.in./rev)	Minimum Adj. Flow cm <sup>3</sup> /rev (cu.in./rev)	Max. Operating Pressure MPa (PSI)	Shaft Speed Range r/min		Approx. Mass kg (lbs.)	
				Max.*	Min.	Flange Mtg.	Foot Mtg.
A3H 37-*R09-***K-10*	37.1 (2.26)	16.0 (.976)	35 (5080)	2700	600	23.0 (50.7)	30.5 (67.3)
A3H 56-*R09-***K-10*	56.3 (3.44)	35.0 (2.14)		2500	600	29.0 (63.9)	36.5 (80.5)
A3H 71-*R09-***K-10*	70.7 (4.31)	45.0 (2.75)		2300	600	38.0 (83.8)	45.5 (100)
A3H100-*R09-***K-10*	100.5 (6.13)	63.0 (3.84)		2100	600	48.0 (106)	76.0 (168)
A3H145-*R09-***K-10*	145.2 (8.86)	95.0 (5.80)		1800	600	63.0 (139)	91.0 (201)
A3H180-*R09-***K-10*	180.7 (11.03)	125.0 (7.63)		1800	600	74.2 (164)	102.2 (225)

★ The maximum shaft speeds shown in the above table are at suction pressure 0 kPa (0 PSIG).

## Model Number Designation

A3H37	-F	R	09	-11	A	4	K	-10	*
Series Number	Mounting	Direction of Rotation	Control Type	Input Power Setting	Frequency of Power Source	Pole Number of Electric Motor	Shaft Extension*2	Design Number	Design Std.
<b>A3H37</b> (37.1 cm <sup>3</sup> /rev)	<b>F</b> : Flange Mtg.	<b>R</b> : Clockwise*1 (Normal)  (Viewed from Shaft End)	<b>09</b> : Constant Power (Torque) Control Type	<b>5.5</b> : 5.5 kW   <b>110</b> : 110 kW  Refer to the table on following page for combination.	<b>A</b> : 50 Hz  <b>B</b> : 60 Hz	<b>4</b> : 4 Poles  <b>6</b> : 6 Poles	<b>K</b> : Keyed Shaft	<b>10</b>	Refer to ★3
<b>A3H56</b> (56.3 cm <sup>3</sup> /rev)								<b>10</b>	
<b>A3H71</b> (70.7 cm <sup>3</sup> /rev)	<b>10</b>								
<b>A3H100</b> (100.5 cm <sup>3</sup> /rev)	<b>10</b>								
<b>A3H145</b> (145.2 cm <sup>3</sup> /rev)	<b>10</b>								
<b>A3H180</b> (180.7 cm <sup>3</sup> /rev)	<b>10</b>								

★1. Available to supply pump with anti-clockwise rotation. Consult Yuken for details.

★2. We can also supply spline-type shaft extension. Consult Yuken for details.

★3. Design Standards: None ..... Japanese Standard "JIS"

80 ..... European Design Standard

950 ..... N. American Design Standard (Applicable only for A3H37/56/71)

954 ..... N. American Design Standard (Applicable only for A3H100/145/180)

★4. Mounting type "L" is not available for N. American Design Standard.

★5. Shaft extension "K1" is applicable only for N. American Design Standard.

● **Combination of pump series and input power setting (○ = available combinations)**

Model Numbers		Input Power Setting kW (HP)																					
		Pole Number of Electric Motor : <b>4P</b>										Pole Number of Electric Motor : <b>6P</b>											
		11 (15)	15 (20)	18.5 (25)	22 (30)	30 (40)	37 (50)	45 (60)	55 (75)	75 (100)	90 (120)	110 (150)	5.5 (7.5)	7.5 (10)	11 (15)	15 (20)	18.5 (25)	22 (30)	30 (40)	37 (50)	45 (60)	55 (75)	75 (100)
A3H 37	50 Hz	○	○	○								○	○	○									
	60 Hz	○	○	○									○	○	○								
A3H 56	50 Hz		○	○	○								○	○	○								
	60 Hz		○	○	○	○							○	○	○								
A3H 71	50 Hz			○	○	○	○							○	○	○							
	60 Hz			○	○	○	○							○	○	○							
A3H100	50 Hz				○	○	○	○							○	○	○						
	60 Hz					○	○	○	○						○	○	○				○	○	
A3H145	50 Hz					○	○	○	○	○						○	○	○			○	○	○
	60 Hz						○	○	○	○	○					○	○	○			○	○	○
A3H180	50 Hz						○	○	○	○	○						○	○	○			○	○
	60 Hz							○	○	○	○	○					○	○	○			○	○

■ **Pipe Flange Kits**

For pipe flange, refer to form of pressure compensator type on [page 123](#).

Typical Performance Characteristics of Control Type "09" at Viscosity 32 mm<sup>2</sup>/s [ISO VG32 oils, 40°C (104°F)]

● **A3H37**

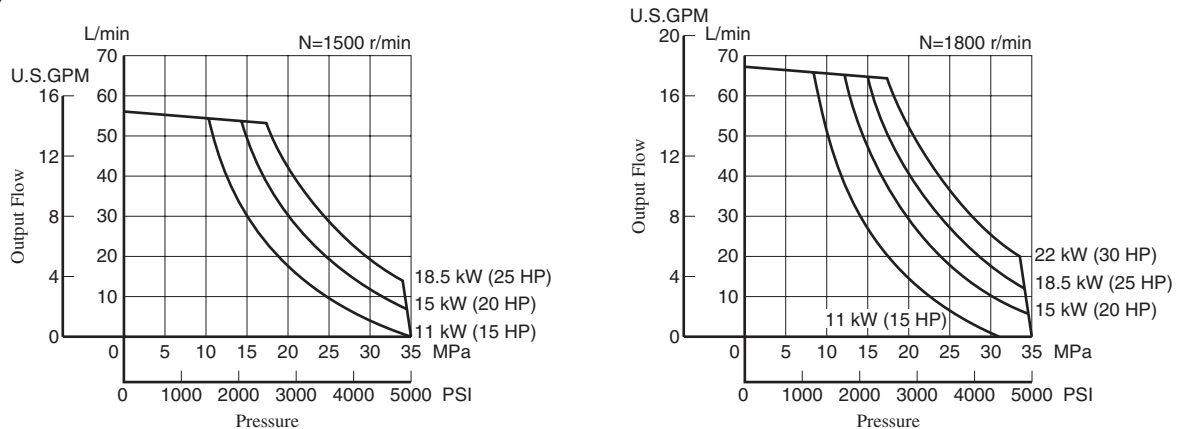

● **A3H56**

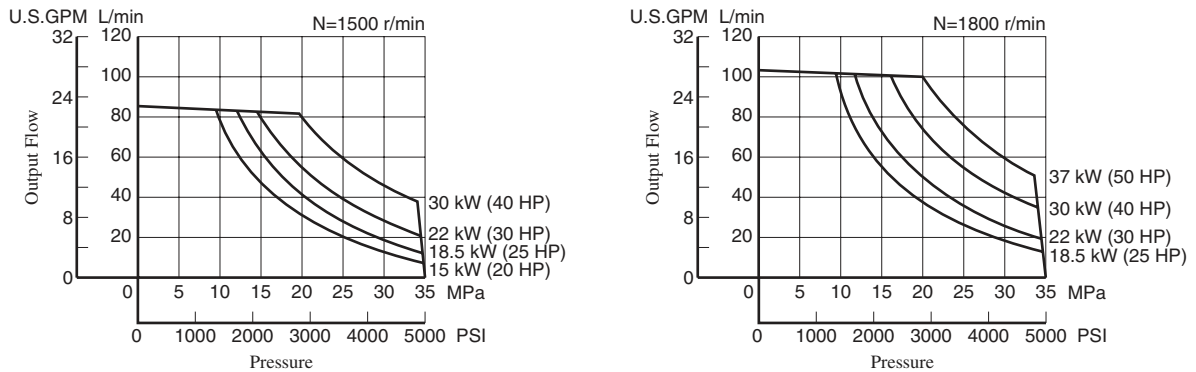



### Typical Performance Characteristics of Control Type "09" at Viscosity 32 mm<sup>2</sup>/s [ISO VG32 oils, 40°C (104°F)]

#### ● A3H71

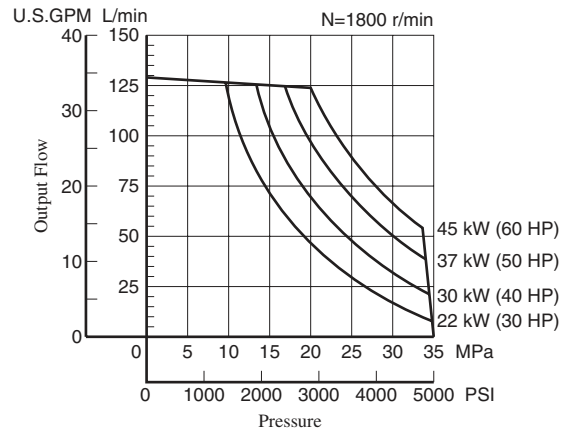
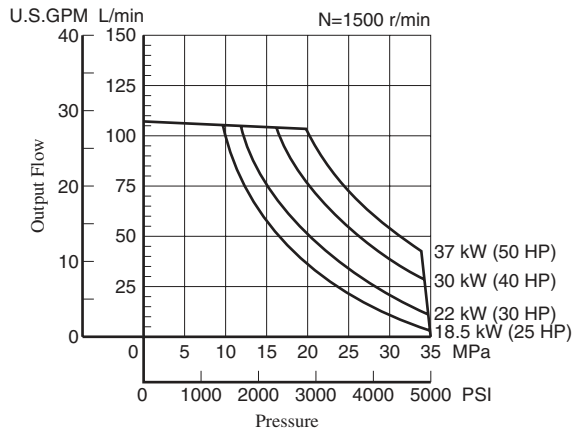

#### ● A3H100

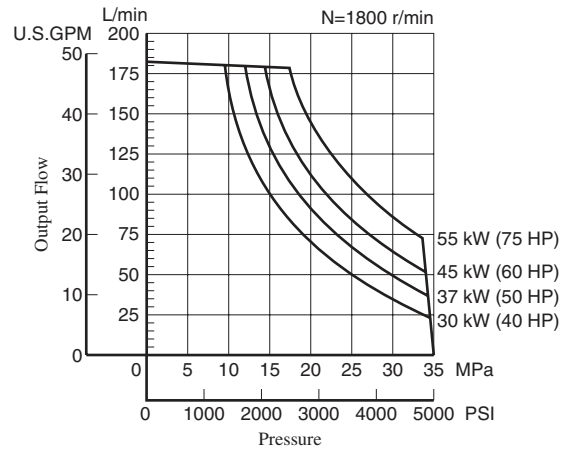
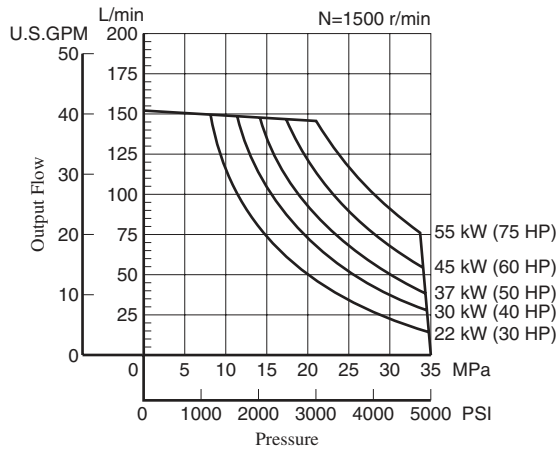

#### ● A3H145

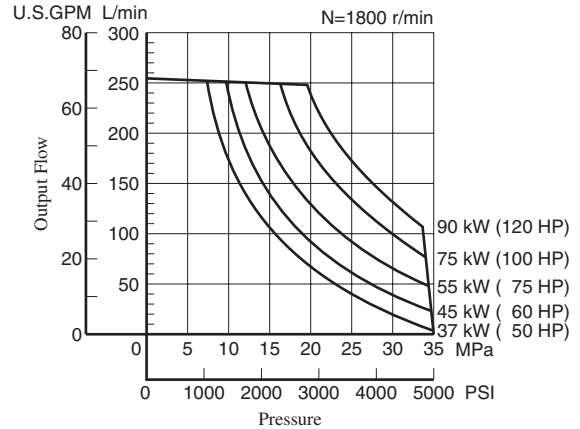
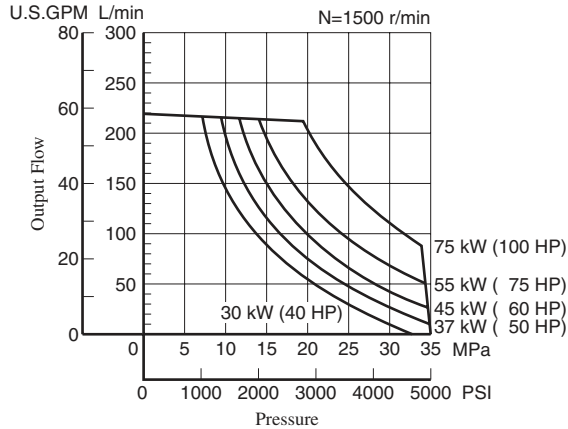

#### ● A3H180

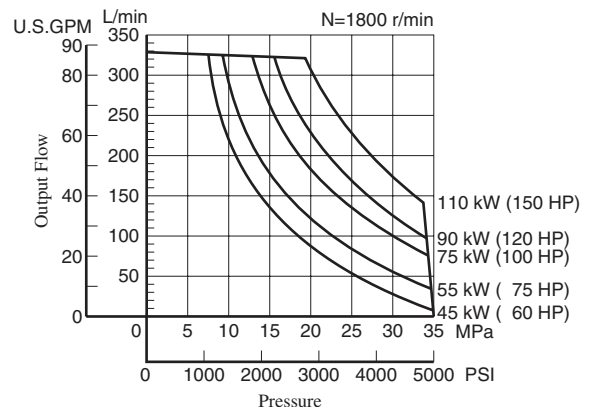
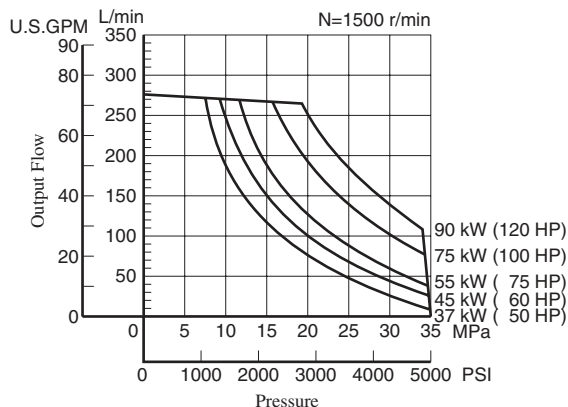

Flange Mtg.: A3H37-FR09-\*\*\*K-10/1080/10950

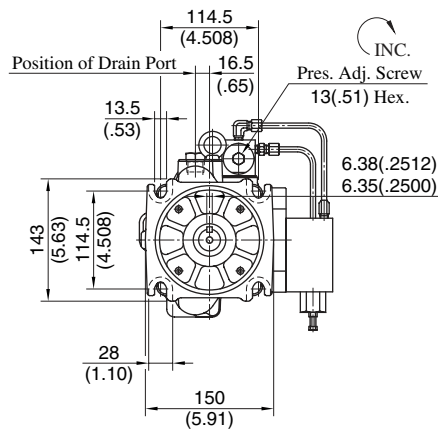
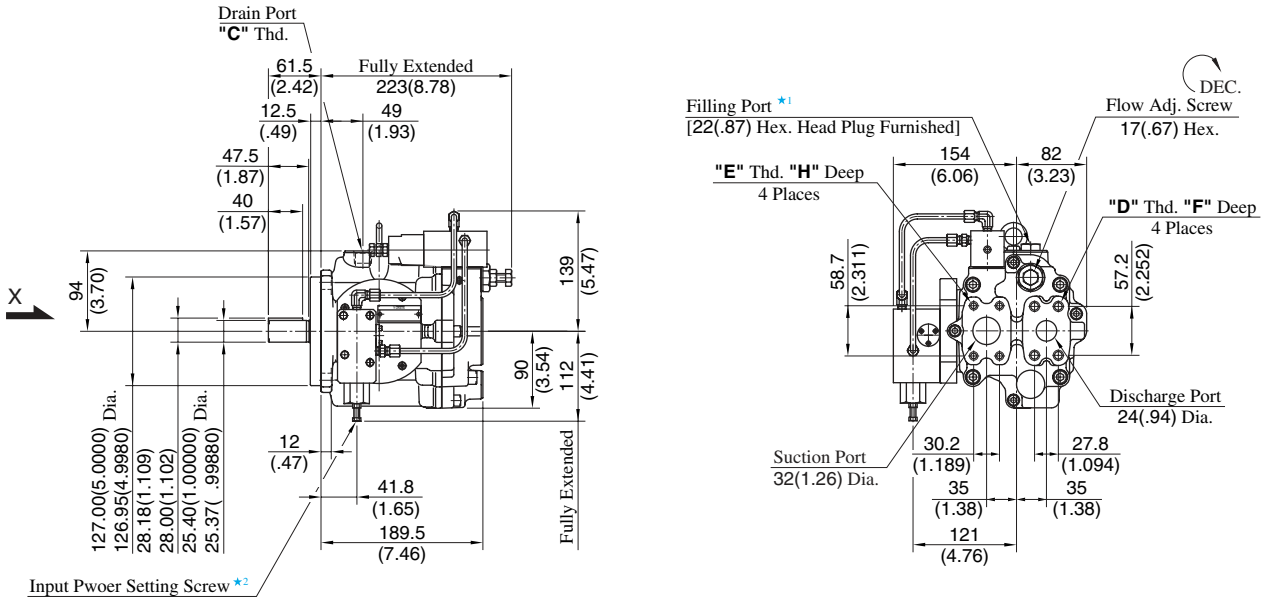

View Arrow X

Model Numbers	Thread Size			Dimensions mm (Inches)	
	C	D	E	F	H
A3H37-FR09-***K-10	Rc 1/2	M12	M10	22 (.87)	18 (.71)
A3H37-FR09-***K-1080	1/2 BSP.F				
A3H37-FR09-***K-10950	SAE #10	1/2-13 UNC	7/16-14 UNC	21 (.83)	20 (.79)

- ★ 1. Install the pump so that the "Filling Port" is at the top.
- ★ 2. Do not touch the screw because it is adjusted at the time of shipment.

DIMENSIONS IN  
MILLIMETRES (INCHES)

● **Foot Mounting Type**

Mounting bracket is common to that of pressure compensator model.  
Refer to [page 133](#) for the dimensions of mounting bracket.

Flange Mtg.: A3H56-FR09-\*\*\*K-10/1080/10950

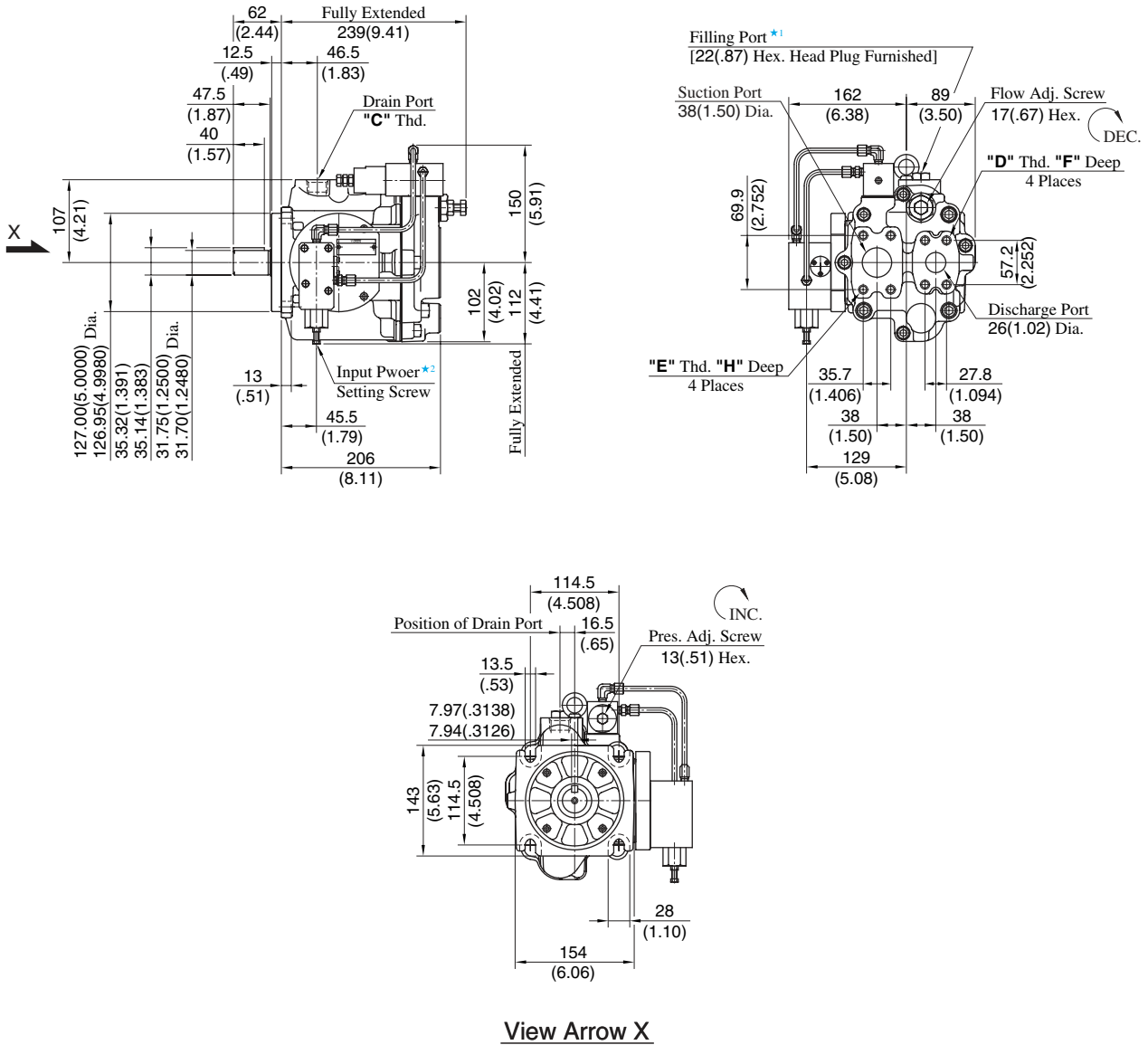

Model Numbers	Thread Size			Dimensions mm (Inches)	
	C	D	E	F	H
A3H56-FR09-***K-10	Rc 3/4	M12	M12	22 (.87)	22 (.87)
A3H56-FR09-***K-1080	3/4 BSP.F				
A3H56-FR09-***K-10950	SAE #12	1/2-13 UNC	7/16-14 UNC	21 (.83)	20 (.79)

- ★ 1. Install the pump so that the "Filling Port" is at the top.
- ★ 2. Do not touch the screw because it is adjusted at the time of shipment.

DIMENSIONS IN MILLIMETRES (INCHES)

● Foot Mounting Type

Mounting bracket is common to that of pressure compensator model. Refer to page 134 for the dimensions of mounting bracket.

Flange Mtg.: A3H71-FR09-\*\*\*K-10/1080/10950

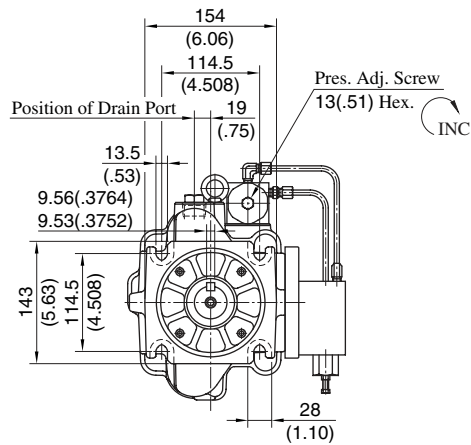
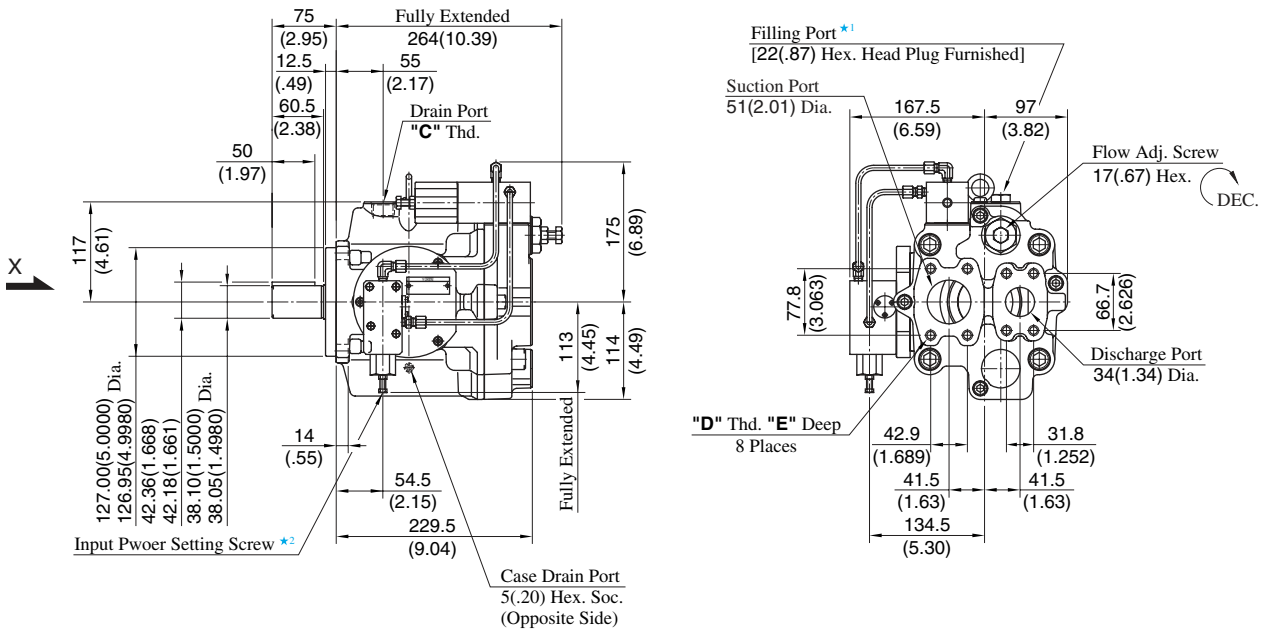

View Arrow X

Model Numbers	Thread Size		Dimensions mm (Inches)
	C	D	E
A3H71-FR09-***K-10	Rc 3/4	M12	19 (.75)
A3H71-FR09-***K-1080	3/4 BSP.F		
A3H71-FR09-***K-10950	SAE #12	1/2-13 UNC	21 (.83)

- ★ 1. Install the pump so that the "Filling Port" is at the top.
- ★ 2. Do not touch the screw because it is adjusted at the time of shipment.

DIMENSIONS IN  
MILLIMETRES (INCHES)

● **Foot Mounting Type**

Mounting bracket is common to that of pressure compensator model.  
Refer to [page 135](#) for the dimensions of mounting bracket.

Flange Mtg.: A3H100-FR09-\*\*\*K-10/1080/10954

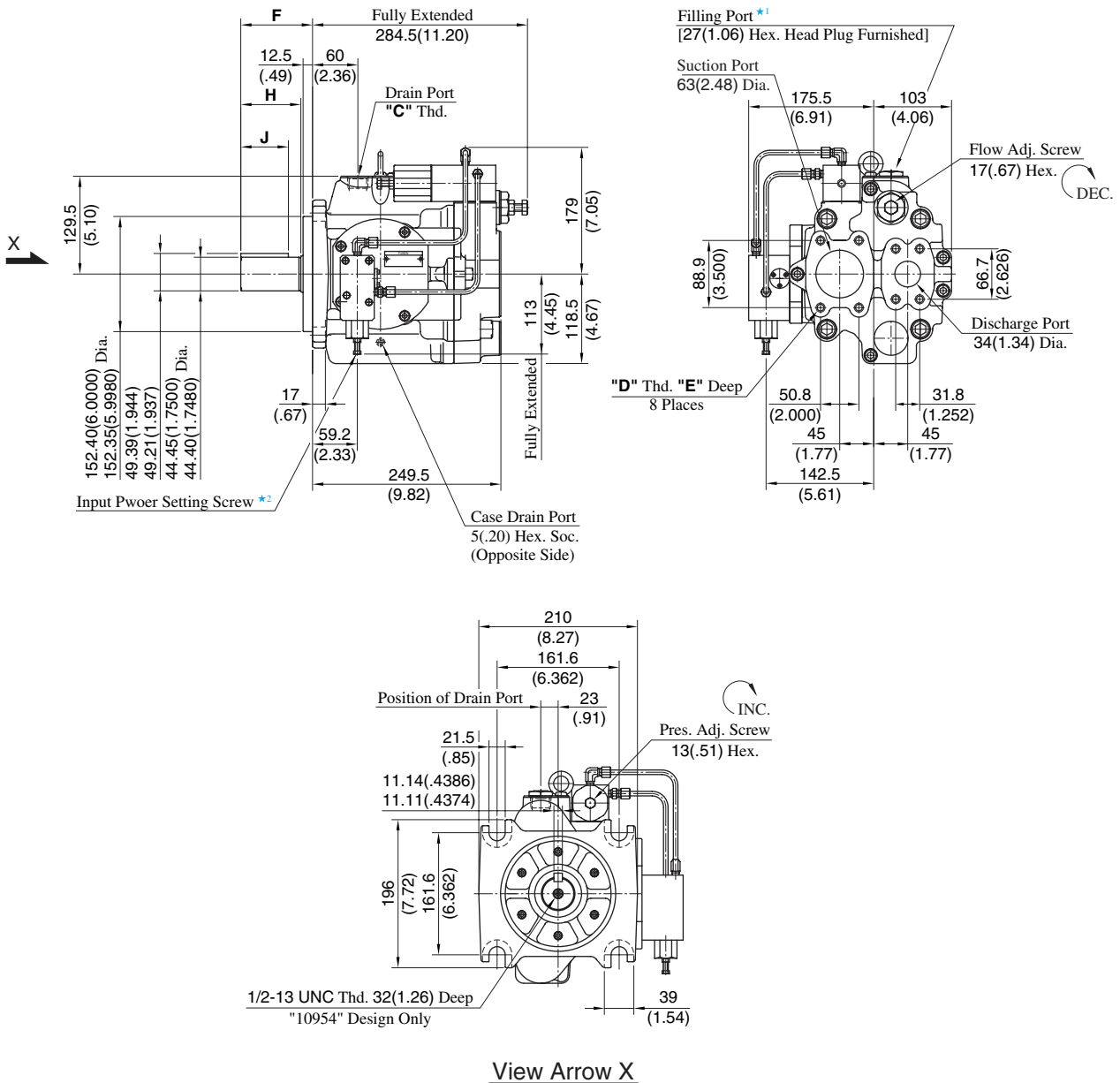

Model Numbers	Thread Size		Dimensions mm (Inches)			
	C	D	E	F	H	J
A3H100-FR09-***K-10	Rc 3/4	M12	19 (.75)	95 (3.74)	81 (3.19)	63 (2.48)
A3H100-FR09-***K-1080	3/4 BSP.F					
A3H100-FR09-***K-10954	SAE #12	1/2-13 UNC	21 (.83)	74.6 (2.94)	60.6 (2.39)	50 (1.97)

- ★ 1. Install the pump so that the "Filling Port" is at the top.
- ★ 2. Do not touch the screw because it is adjusted at the time of shipment.

DIMENSIONS IN MILLIMETRES (INCHES)

● **Foot Mounting Type**

Mounting bracket is common to that of pressure compensator model. Refer to page 136 for the dimensions of mounting bracket.

Flange Mtg.: A3H145-FR09-\*\*\*K\*-10/1080/10954

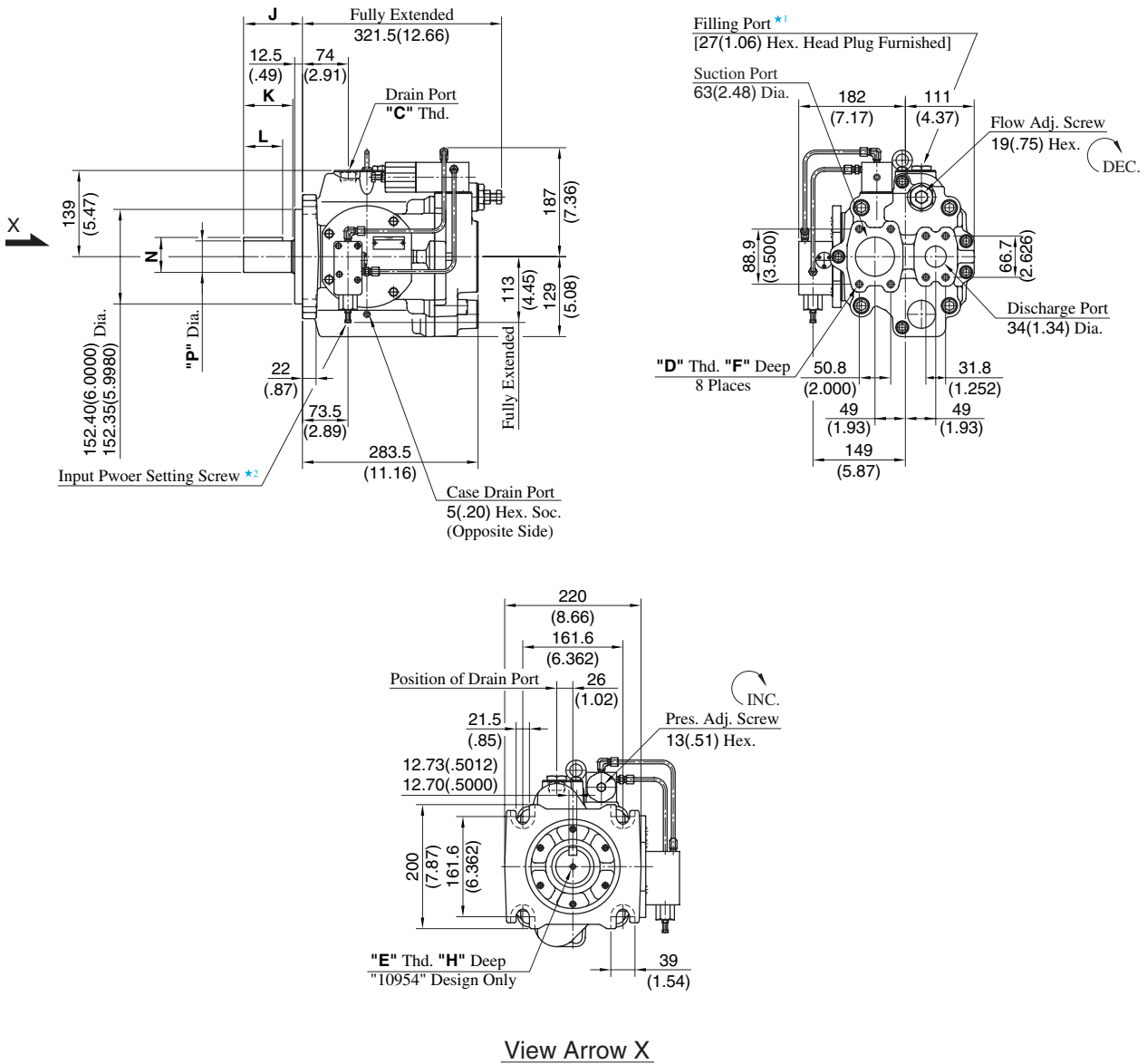

View Arrow X

Model Numbers	Thread Size			Dimensions mm (Inches)						
	C	D	E	F	H	J	K	L	N	P
A3H145-FR09-***K-10	Rc 3/4	M12	—	19 (.75)	—	95 (3.74)	81 (3.19)	63 (2.48)	56.43 (2.222)	50.80 (2.0000)
A3H145-FR09-***K-1080	3/4 BSP.F		—	—	—	—	—	—	—	56.25 (2.215)
A3H145-FR09-***K-10954	SAE #12	1/2-13 UNC	1/2-13 UNC	21 (.83)	32 (1.26)	74.6 (2.94)	60.6 (2.39)	50 (1.97)	49.39 (1.944)	44.45 (1.7500)
A3H145-FR09-***K1-10954			5/8-11 UNC		36 (1.42)				—	—
									56.25 (2.215)	50.75 (1.9980)

- ★ 1. Install the pump so that the "Filling Port" is at the top.
- ★ 2. Do not touch the screw because it is adjusted at the time of shipment.

DIMENSIONS IN  
MILLIMETRES (INCHES)

● **Foot Mounting Type**

Mounting bracket is common to that of pressure compensator model.  
Refer to [page 137](#) for the dimensions of mounting bracket.



Flange Mtg.: A3H180-FR09-\*\*\*K\*-10/1080/10954

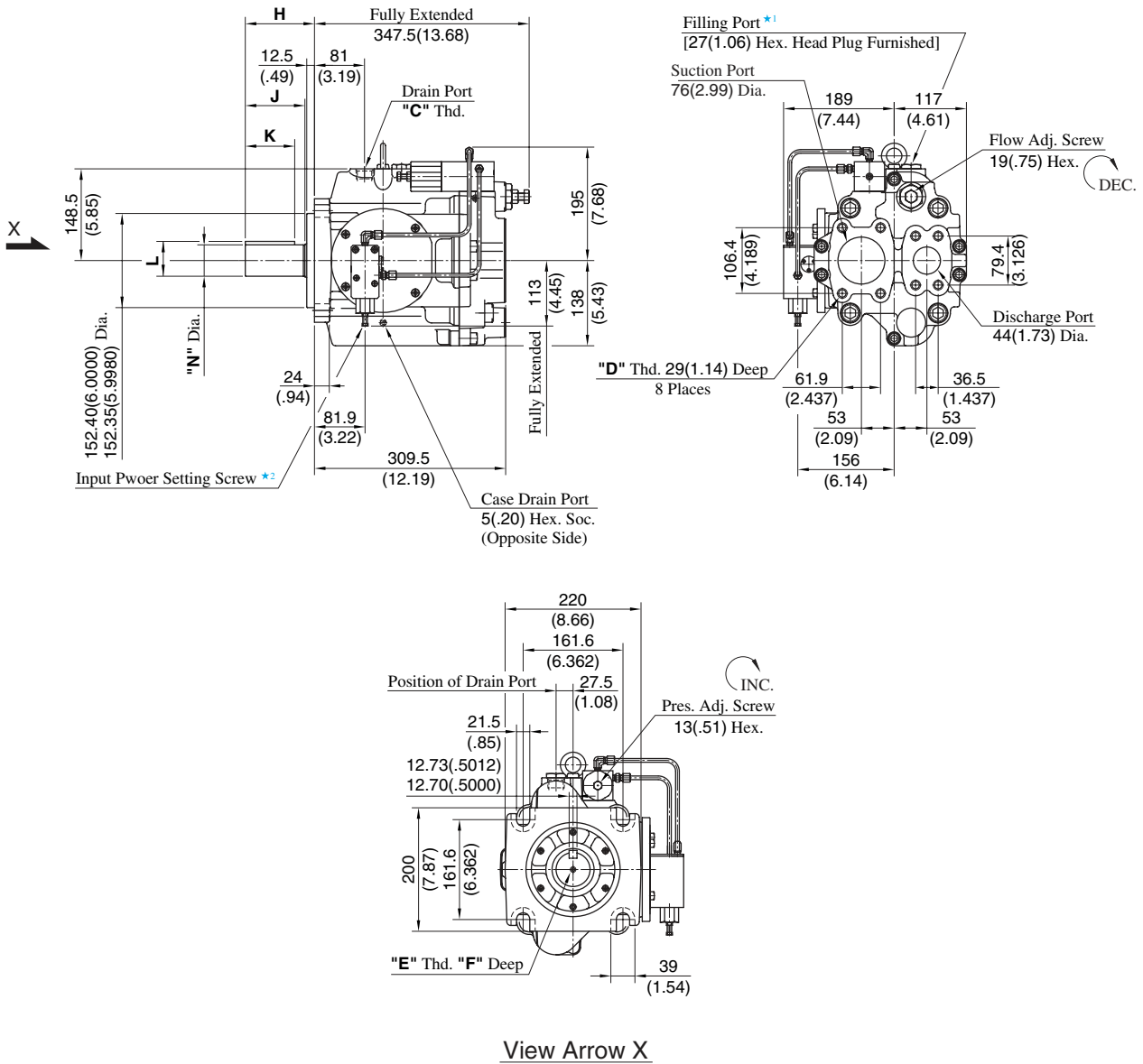

View Arrow X

Model Numbers	Thread Size			Dimensions mm (Inches)					
	C	D	E	F	H	J	K	L	N
A3H180-FR09-***K-10	Rc 3/4	M16	—	—	112 (4.41)	97.5 (3.84)	80 (3.15)	56.43 (2.222)	50.80 (2.0000)
A3H180-FR09-***K-1080	3/4 BSP.F		—	—	—	—	—	56.25 (2.215)	50.75 (1.9980)
A3H180-FR09-***K-10954	SAE #12	5/8-11 UNC	1/2-13 UNC	32 (1.26)	99.8 (3.93)	85.3 (3.36)	70 (2.76)	49.39 (1.944)	44.45 (1.7500)
A3H180-FR09-***K1-10954			5/8-11 UNC	36 (1.42)				56.43 (2.222)	50.80 (2.0000)
								56.25 (2.215)	50.75 (1.9980)

- ★ 1. Install the pump so that the "Filling Port" is at the top.
- ★ 2. Do not touch the screw because it is adjusted at the time of shipment.

DIMENSIONS IN MILLIMETRES (INCHES)

● Foot Mounting Type

Mounting bracket is common to that of pressure compensator model. Refer to page 138 for the dimensions of mounting bracket.

# "A3H" Series Variable Displacement Piston Pumps-Single Pump, Load Sensing Type

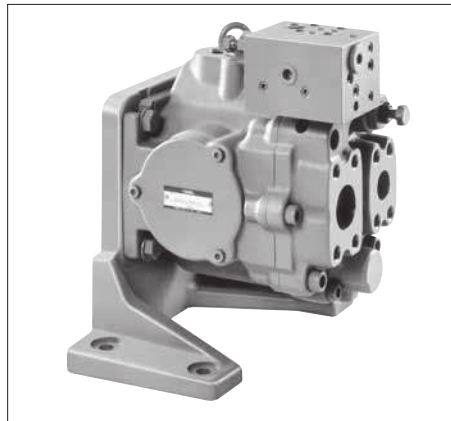

Graphic Symbol

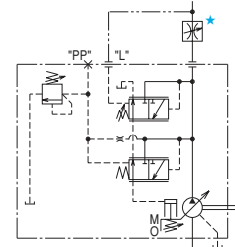

★ A flow control valve is not included with the pump. Install the valve separately.

## Specifications

Model Numbers	Geometric Displacement cm <sup>3</sup> /rev (cu.in./rev)	Operating Pressure <sup>★1</sup> MPa (PSI)		Load Sensing Pres. Difference $\Delta P$ MPa (PSI)	Shaft Speed Range r/min		Approx. Mass kg (lbs.)	
		Rated	Intermittent		Max. <sup>★3</sup>	Min.	Flange Mtg.	Foot Mtg.
A3H 16-*R14K-10*	16.3 (.995)	28 (4060)	35 (5080)	1.5 (218) (At the time of shipment) <sup>★2</sup>	3600	600	17.5 (38.6)	26.4 (58.2)
A3H 37-*R14K-10*	37.1 (2.26)				2700	600	22.5 (49.6)	30.0 (66.2)
A3H 56-*R14K-10*	56.3 (3.44)				2500	600	28.7 (63.3)	36.2 (79.8)
A3H 71-*R14K-10*	70.7 (4.31)				2300	600	38.0 (83.8)	45.5 (100)
A3H100-*R14K-10*	100.5 (6.13)				2100	600	47.6 (105)	75.6 (167)
A3H145-*R14K-10*	145.2 (8.86)				1800	600	63.0 (139)	91.0 (201)
A3H180-*R14K-10*	180.7 (11.03)				1800	600	73.4 (162)	101.4 (224)

- ★1. The operating pressure means pump discharge pressure.
- ★2. Load pressure difference  $\Delta P$  is adjustable in range of 1.0 -3.0 MPa (145-435 PSI).
- ★3. The maximum shaft speeds shown in the above table are at suction pressure 0 kPa (0 PSIG).

## Model Number Designation

A3H37	-F	R	14	K	-10	*	
Series Number	Mounting	Direction of Rotation	Control Type	Shaft Extension <sup>★2</sup>	Design Number	Design Std.	
<b>A3H16</b> (16.3 cm <sup>3</sup> /rev)	<b>F:</b> Flange Mtg.	(Viewed from Shaft End) <b>R:</b> Clockwise <sup>★1</sup> (Normal)	<b>14:</b> Load Sensing Type	<b>K :</b> Keyed Shaft	<b>10</b>	Refer to ★3	
<b>A3H37</b> (37.1 cm <sup>3</sup> /rev)					<b>10</b>		
<b>A3H56</b> (56.3 cm <sup>3</sup> /rev)					<b>10</b>		
<b>A3H71</b> (70.7 cm <sup>3</sup> /rev)	<b>10</b>						
<b>A3H100</b> (100.5 cm <sup>3</sup> /rev)	<b>F:</b> Flange Mtg.				<b>10</b>		
<b>A3H145</b> (145.2 cm <sup>3</sup> /rev)	<b>L:</b> Foot Mtg. <sup>★4</sup>				<b>K :</b> Keyed Shaft [44.45mm (1.75 IN.) Dia.]		<b>10</b>
<b>A3H180</b> (180.7 cm <sup>3</sup> /rev)					<b>K1:</b> Keyed Shaft <sup>★5</sup> [50.8mm (2.0 IN.) Dia.]		<b>10</b>

- ★1. Available to supply pump with anti-clockwise rotation. Consult Yuken for details.
- ★2. We can also supply spline-type shaft extension. Consult Yuken for details.
- ★3. Design Standards: None ..... Japanese Standard "JIS"  
80 ..... European Design Standard  
950 ..... N. American Design Standard (Applicable only for A3H16/37/56/71)  
954 ..... N. American Design Standard (Applicable only for A3H100/145/180)
- ★4. Mounting type "L" is not available for N. American Design Standard.
- ★5. Shaft extension "K1" is applicable only for N. American Design Standard.



■ Pipe Flange Kits

For pipe flange, refer to form of pressure compensator type on page 123.

Typical Performance Characteristics of Control Type "A3H71" at Viscosity 32 mm<sup>2</sup>/s [ISO VG32 oils, 40°C (104°F)]

● Pressure vs. Output Flow

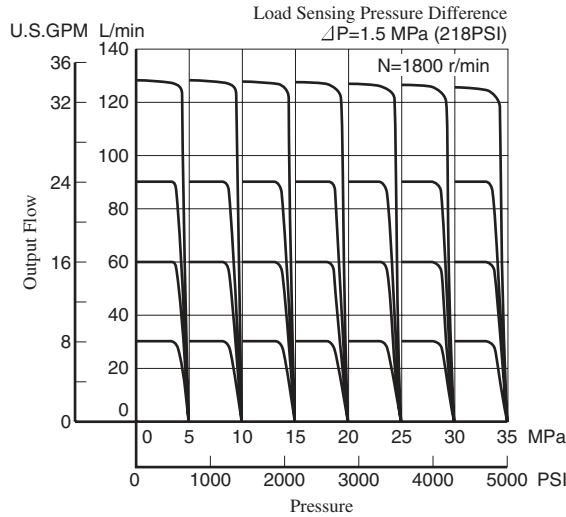

● Full Cut-off Input Power

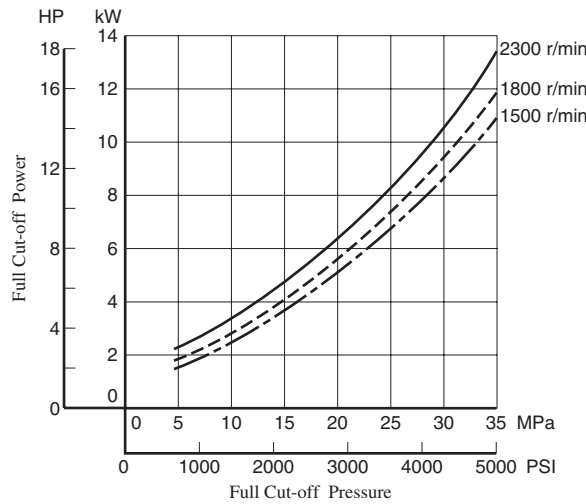

● Drain

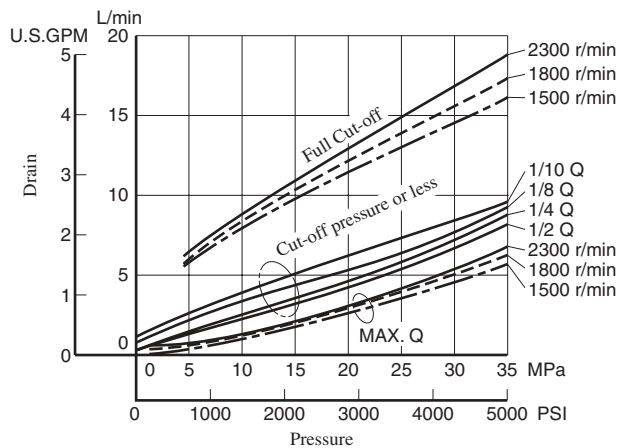

★ Ask Yuken for Performance characteristics of other series than A3H71.

Flange Mtg.: A3H16-FR14K-10/1080/10950

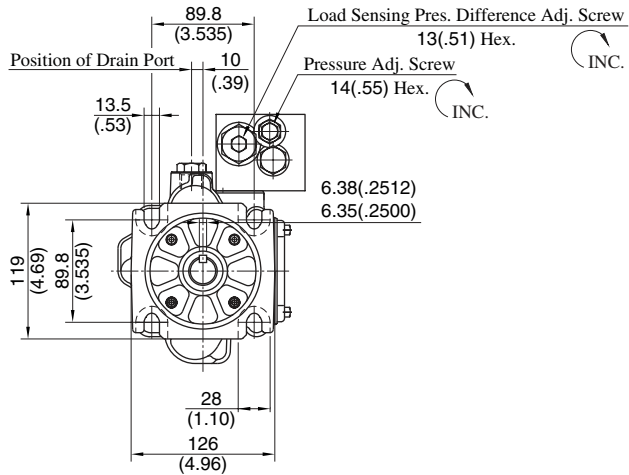
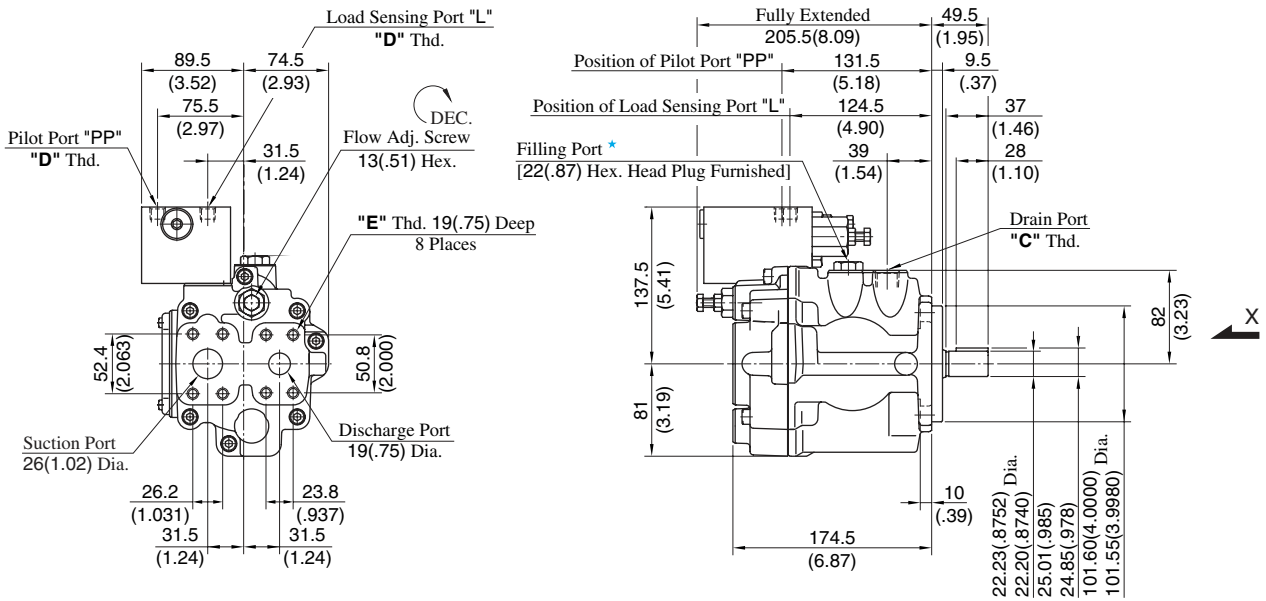

View Arrow X

Model Numbers	Thread Size		
	C	D	E
A3H16-FR14K-10	Rc 1/2	Rc 1/4	M10
A3H16-FR14K-1080	1/2 BSP.F	1/4 BSP.F	
A3H16-FR14K-10950	SAE #10	SAE #4	7/16-14 UNC

★ Install the pump so that the "Filling Port" is at the top.

**DIMENSIONS IN MILLIMETRES (INCHES)**

● **Foot Mounting Type**

Mounting bracket is common to that of pressure compensator model.  
Refer to [page 132](#) for the dimensions of mounting bracket.

Flange Mtg.: A3H37-FR14K-10/1080/10950

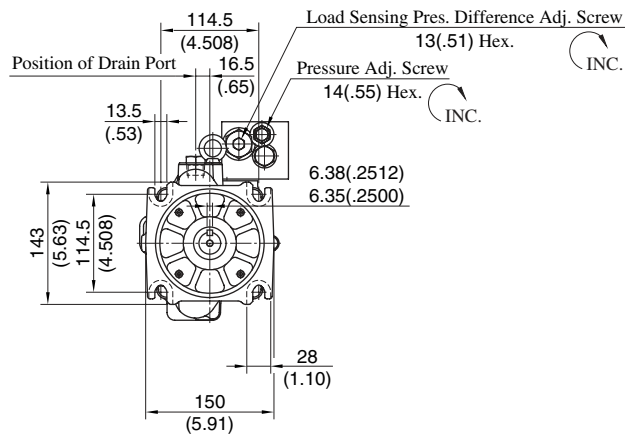
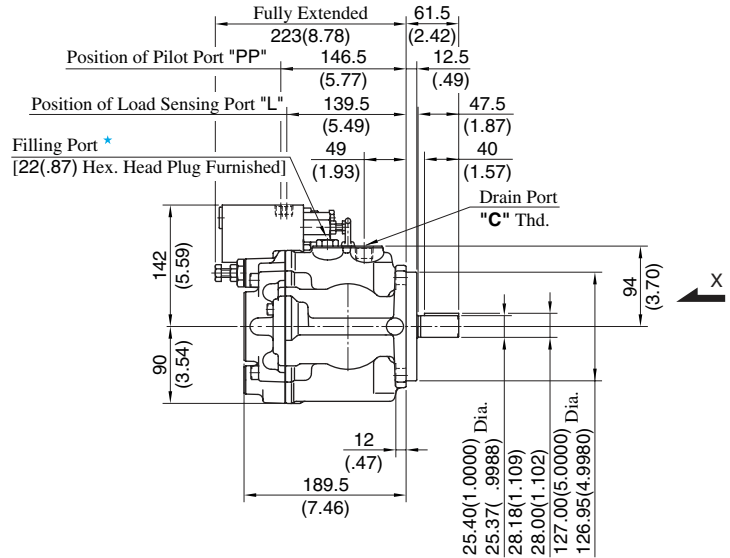
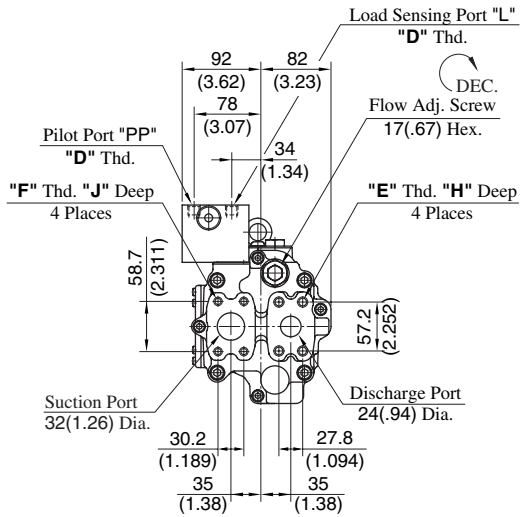

View Arrow X

Model Numbers	Thread Size				Dimensions mm (Inches)	
	C	D	E	F	H	J
A3H37-FR14K-10	Rc 1/2	Rc 1/4	M12	M10	22 (.87)	18 (.71)
A3H37-FR14K-1080	1/2 BSP.F	1/4 BSP.F				
A3H37-FR14K-10950	SAE #10	SAE #4	1/2-13 UNC	7/16-14 UNC	21 (.83)	20 (.79)

★ Install the pump so that the "Filling Port" is at the top.

DIMENSIONS IN MILLIMETRES (INCHES)

● Foot Mounting Type

Mounting bracket is common to that of pressure compensator model. Refer to page 133 for the dimensions of mounting bracket.

Flange Mtg.: A3H56-FR14K-10/1080/10950

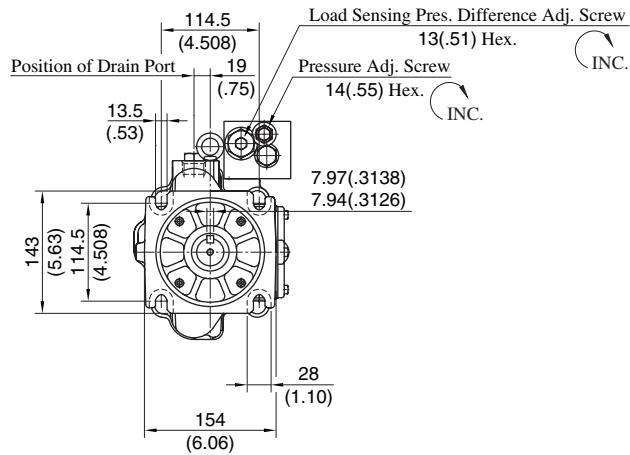
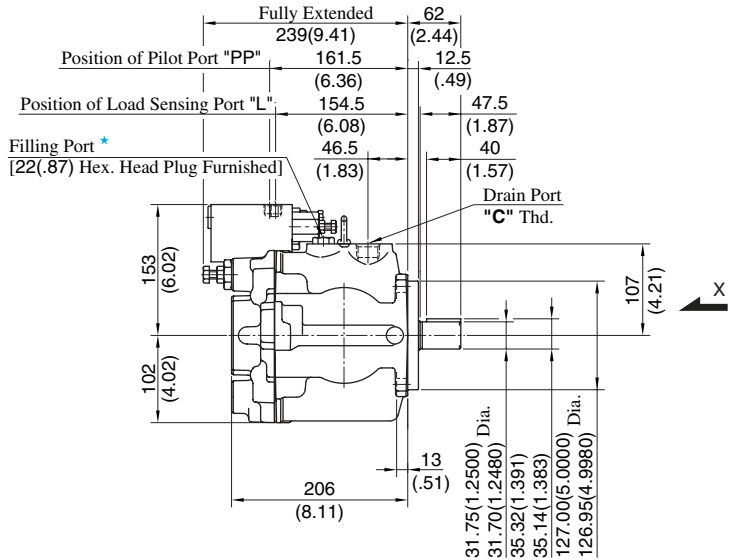
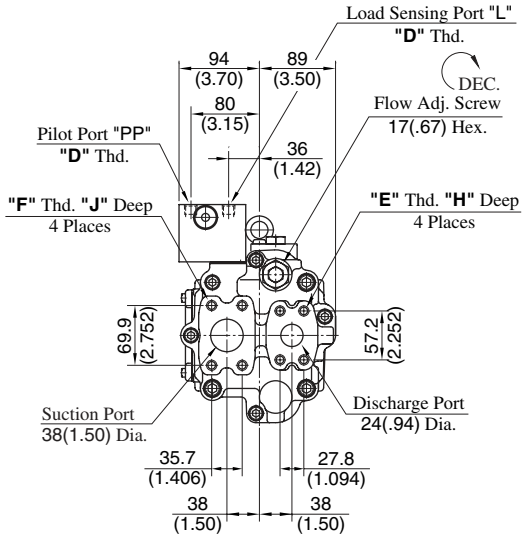

View Arrow X

Model Numbers	Thread Size				Dimensions mm (Inches)	
	C	D	E	F	H	J
A3H56-FR14K-10	Rc 3/4	Rc 1/4	M12	M12	22 (.87)	22 (.87)
A3H56-FR14K-1080	3/4 BSP.F	1/4 BSP.F				
A3H56-FR14K-10950	SAE #12	SAE #4	1/2-13 UNC	7/16-14 UNC	21 (.83)	20 (.79)

★ Install the pump so that the "Filling Port" is at the top.

**DIMENSIONS IN  
MILLIMETRES (INCHES)**

● **Foot Mounting Type**

Mounting bracket is common to that of pressure compensator model.  
Refer to [page 134](#) for the dimensions of mounting bracket.

Flange Mtg.: A3H71-FR14K-10/1080/10950

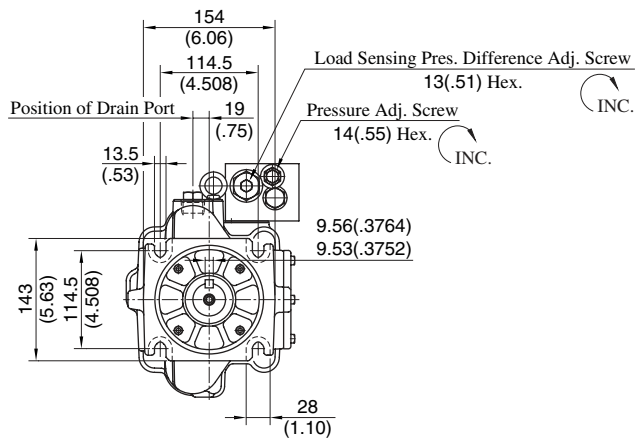
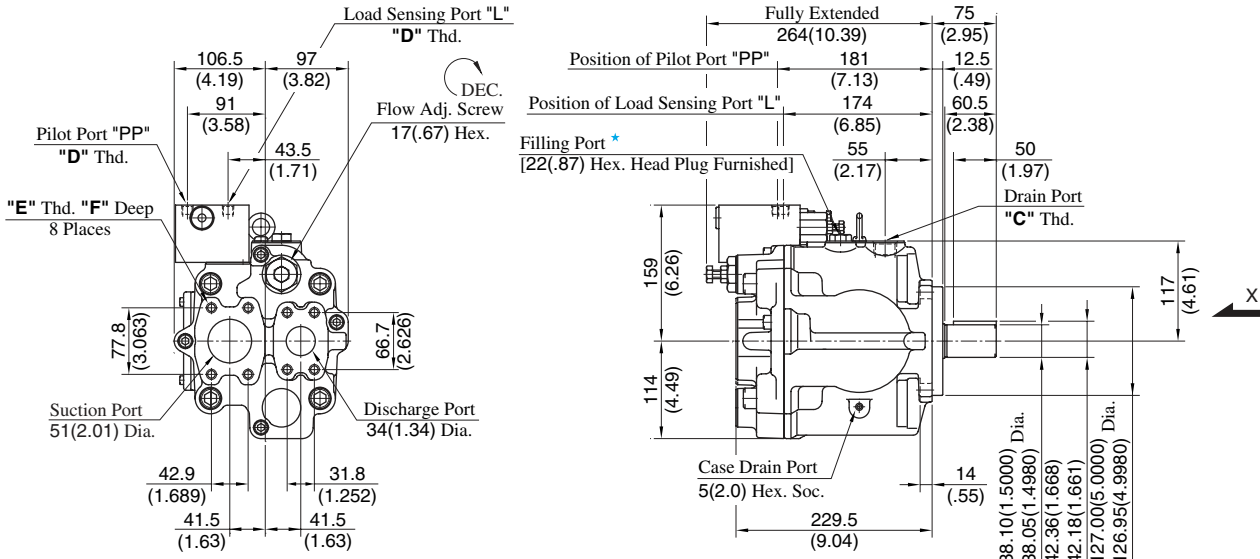

View Arrow X

Model Numbers	Thread Size			Dimensions mm (Inches)
	C	D	E	F
A3H71-FR14K-10	Rc 3/4	Rc 1/4	M12	19 (.75)
A3H71-FR14K-1080	3/4 BSP.F	1/4 BSP.F		
A3H71-FR14K-10950	SAE #12	SAE #4	1/2-13 UNC	21 (.83)

★ Install the pump so that the "Filling Port" is at the top.

DIMENSIONS IN  
MILLIMETRES (INCHES)

● Foot Mounting Type

Mounting bracket is common to that of pressure compensator model.  
Refer to page 135 for the dimensions of mounting bracket.

Flange Mtg.: A3H100-FR14K-10/1080/10954

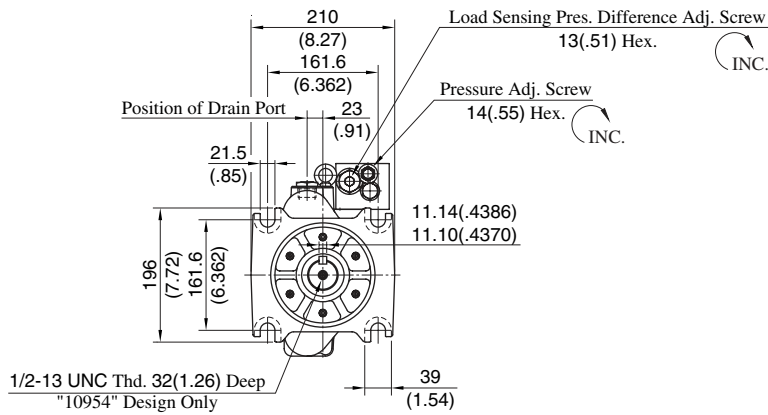
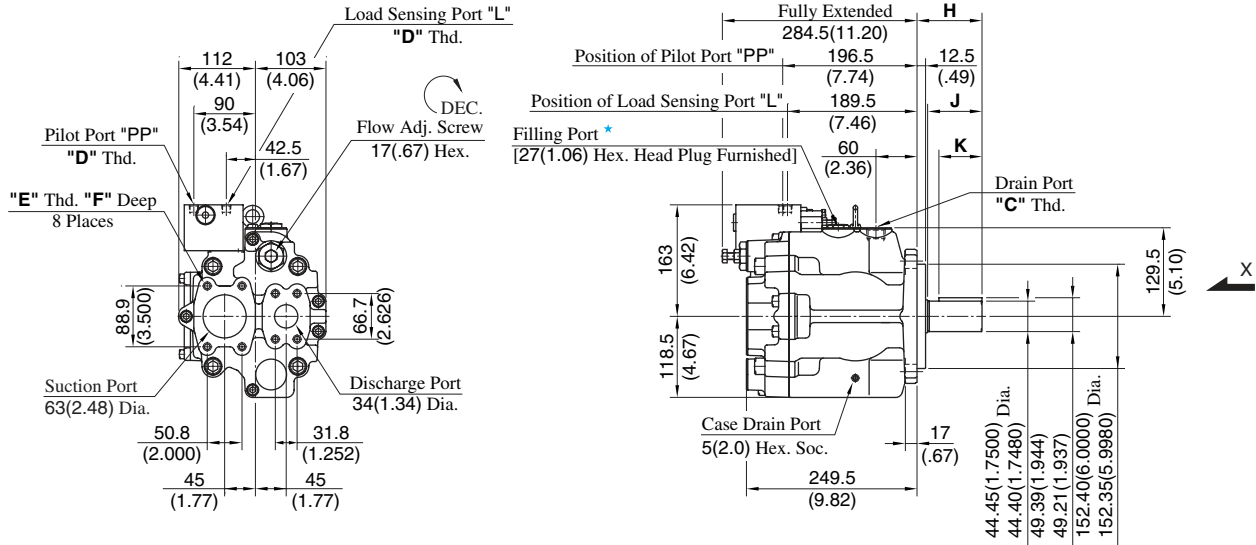

View Arrow X

Model Numbers	Thread Size			Dimensions mm (Inches)			
	C	D	E	F	H	J	K
A3H100-FR14K-10	Rc 3/4	Rc 1/4	M12	19 (.75)	95 (3.74)	81 (3.19)	63 (2.48)
A3H100-FR14K-1080	3/4 BSP.F	1/4 BSP.F					
A3H100-FR14K-10954	SAE #12	SAE #4	1/2-13 UNC	21 (.83)	74.6 (2.94)	60.6 (2.39)	50 (1.97)

★ Install the pump so that the "Filling Port" is at the top.

**DIMENSIONS IN MILLIMETRES (INCHES)**

● **Foot Mounting Type**

Mounting bracket is common to that of pressure compensator model. Refer to page 136 for the dimensions of mounting bracket.



Flange Mtg.: A3H145-FR14K\*-10/1080/10954

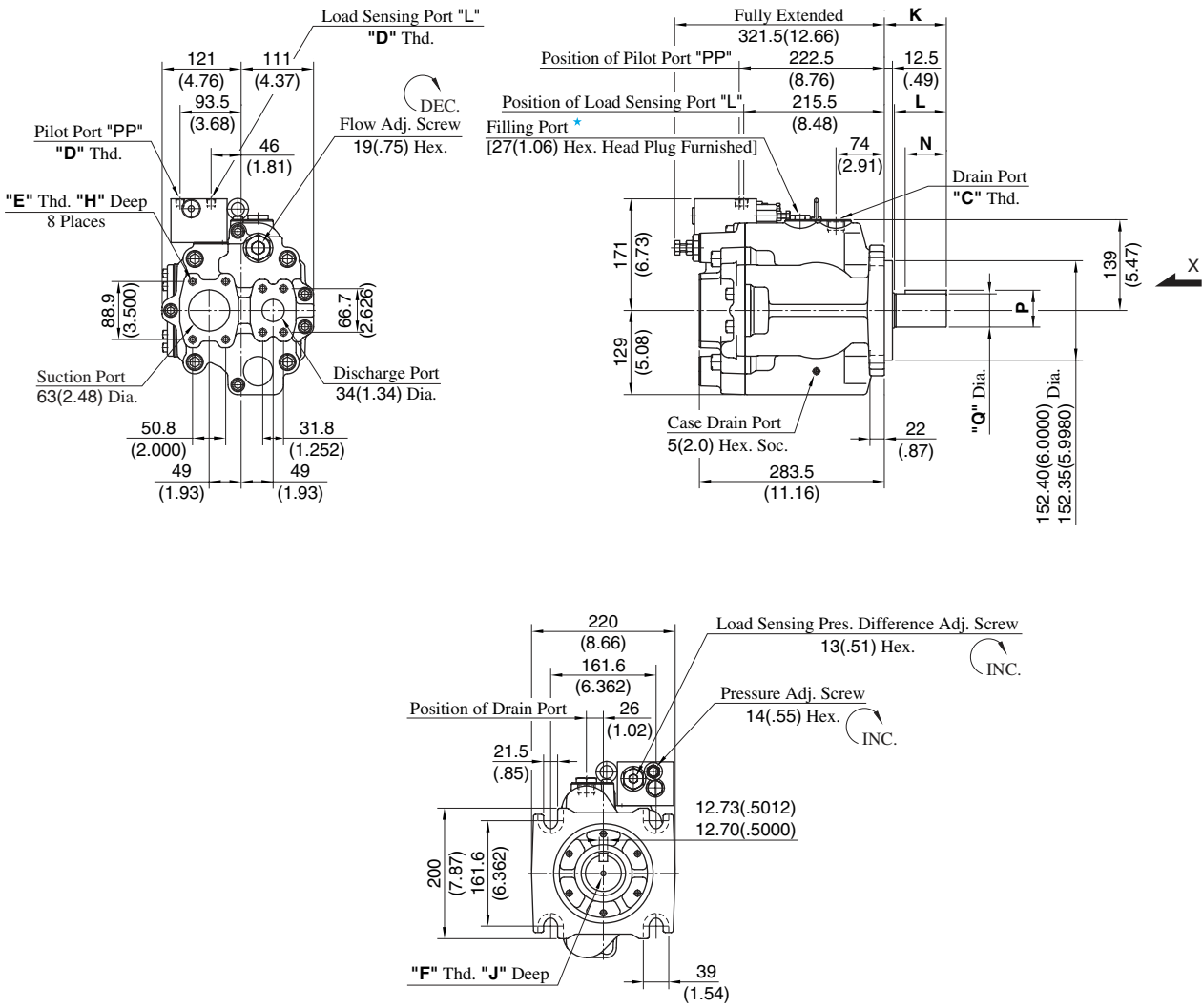

View Arrow X

Model Numbers	Thread Size			Dimensions mm (Inches)							
	C	D	E	F	H	J	K	L	N	P	Q
A3H145-FR14K-10	Rc 3/4	Rc 1/4	M12	—	19 (.75)	—	95 (3.74)	81 (3.19)	63 (2.48)	56.43 (2.222)	50.80 (2.0000)
A3H145-FR14K-1080	3/4 BSP.F	1/4 BSP.F								56.25 (2.215)	50.75 (1.9980)
A3H145-FR14K-10954	SAE #12	SAE #4	1/2-13 UNC	1/2-13 UNC	21 (.83)	32 (1.26)	74.6 (2.94)	60.6 (2.39)	50 (1.97)	49.39 (1.944)	44.45 (1.7500)
A3H145-FR14K1-10954			5/8-11 UNC							36 (1.42)	49.21 (1.937)
										56.43 (2.222)	50.80 (2.0000)
										56.25 (2.215)	50.75 (1.9980)

★ Install the pump so that the "Filling Port" is at the top.

DIMENSIONS IN MILLIMETRES (INCHES)

● Foot Mounting Type

Mounting bracket is common to that of pressure compensator model. Refer to page 137 for the dimensions of mounting bracket.

Flange Mtg.: A3H180-FR14K\*-10/1080/10954

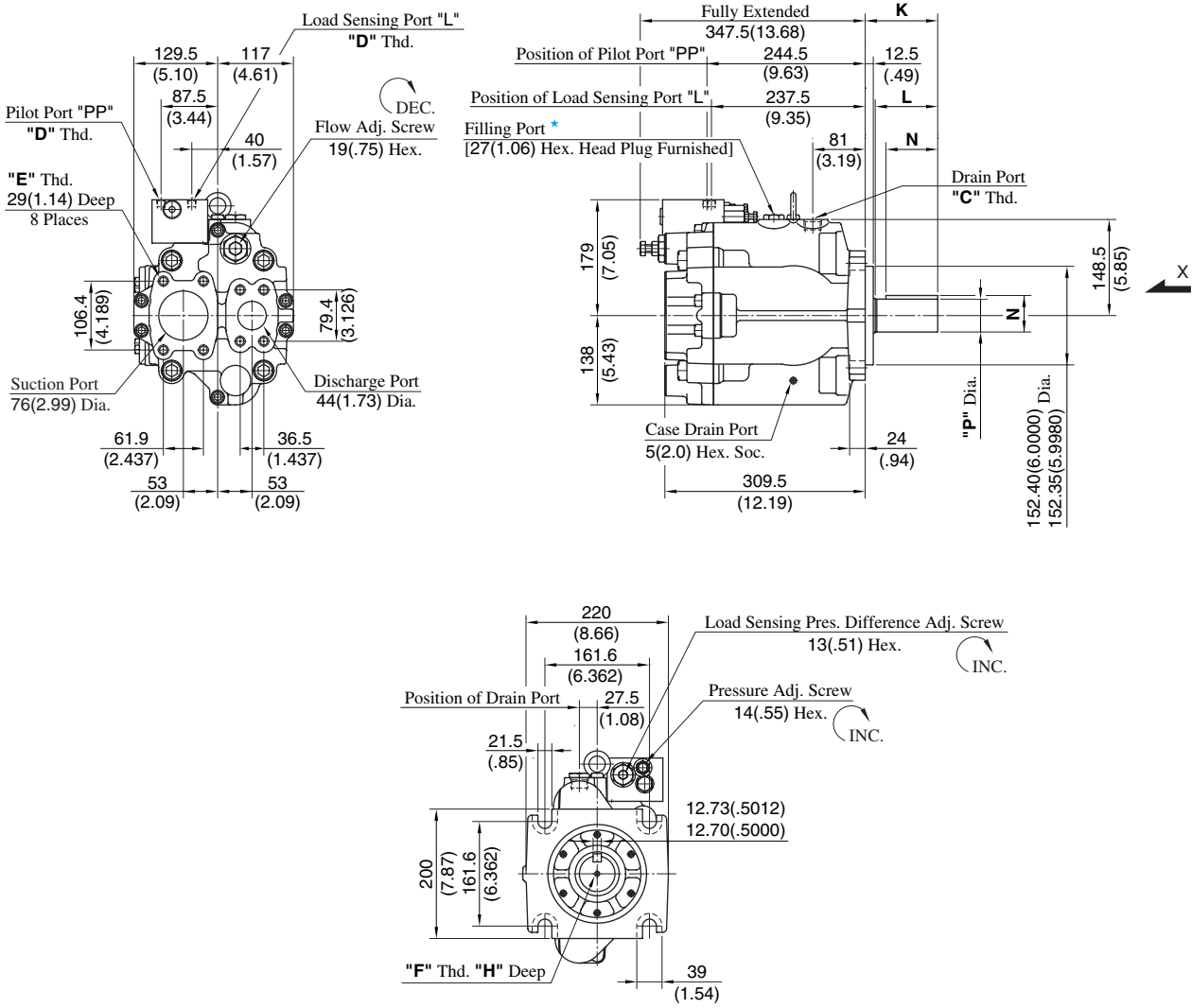

View Arrow X

Model Numbers	Thread Size			Dimensions mm (Inches)						
	C	D	E	F	H	J	K	L	N	P
A3H180-FR14K-10	Rc 3/4	Rc 1/4	M12	—	—	112 (4.41)	97.5 (3.84)	80 (3.15)	56.43 (2.222)	50.80 (2.0000)
A3H180-FR14K-1080	3/4 BSP.F	1/4 BSP.F							56.25 (2.215)	50.75 (1.9980)
A3H180-FR14K-10954	SAE #12	SAE #4	1/2-13 UNC	32 (1.26)	99.8 (3.93)	85.3 (3.36)	70 (2.76)	49.39 (1.944)	44.45 (1.7500)	
A3H180-FR14K1-10954			5/8-11 UNC	36 (1.42)				56.43 (2.222)	50.80 (2.0000)	
									56.25 (2.215)	50.75 (1.9980)

★ Install the pump so that the "Filling Port" is at the top.

**DIMENSIONS IN MILLIMETRES (INCHES)**

● **Foot Mounting Type**

Mounting bracket is common to that of pressure compensator model.  
Refer to page 138 for the dimensions of mounting bracket.