

## ■ Proportional Electro-Hydraulic Relieving and Reducing Valves

This valve is derived by combining a small, high-performance 1/8 proportional electro-hydraulic pilot relief valve with a relieving and reducing valve.

With this valve, it is possible to regulate the system pressure in proportion to the input current.

Incorporating a relief mechanism, this valve provides a good response speed and the pressure decreases even if the load is large. Note that this valve is used in conjunction with the applicable power amplifier.

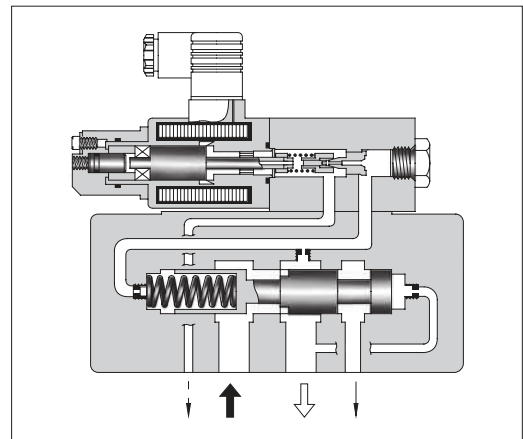
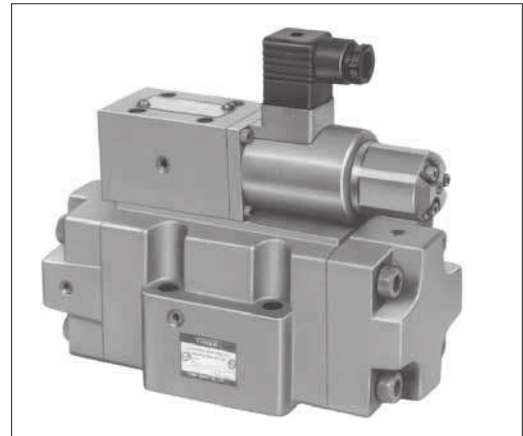

### ■ Specifications

Model Numbers	ERBG-06	ERBG-10
Description		
Max. Operating Pres. MPa (PSI)	24.5 (3550)	24.5 (3550)
Max. Flow L/min(U.S.GPM)	100 (26.4)	250 (66)
Max. Relieving Flow L/min(U.S.GPM)	35 (9.24) *	15 (3.96) *
Secondary Pres. Adj. Range MPa (PSI)	Refer to Model Number Designation	
Rated Current	B : 800 mA C : 800 mA H : 950 mA	B : 800 mA C : 800 mA H : 950 mA
Coil Resistance	10 Ω	10 Ω
Hysteresis	3% or less	3% or less
Repeatability	1% or less	1% or less
Approx. Mass kg (lbs.)	12 (26.5)	13.5 (29.8)

★ The values shown are those obtained where the differential pressure between the secondary pressure port and tank port is 13.7 MPa (2000 PSI).

Graphic Symbol

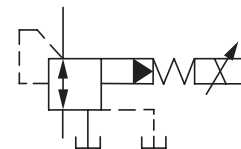

### ■ Model Number Designation

F-	ERB	G	-06	-C	-51	*
Special Seals	Series Number	Type of Mounting	Valve Size	Secondary Pres. Adj. Range MPa (PSI)	Design Number	Design Standards
<b>F:</b> Special Seals for Phosphate Ester Type Fluid (Omit if not required)	<b>ERB:</b> Proportional Electro-Hydraulic Relieving and Reducing Valve	<b>G:</b> Sub-plate Mounting	<b>06</b>	<b>B:</b> 0.8 - 6.9 (115 - 1000) <b>C:</b> 1.2 - 13.7 (175 - 2000) <b>H:</b> 1.5 - 20.6 (220 - 3000)	<b>51</b>	Refer to ★
			<b>10</b>	<b>B:</b> 0.9 - 6.9 (130 - 1000) <b>C:</b> 1.2 - 13.7 (175 - 2000) <b>H:</b> 1.5 - 20.6 (220 - 3000)		

★ Design Standards: None ..... Japanese Standard "JIS" and European Design Standard 90 ..... N. American Design Standard

**H**  
E Series  
Relieving and Reducing Valves

■ Attachment

● Mounting Bolts

Valve Model Numbers	Socket Head Cap Screw		
	Japanese Standard "JIS" & European Design Standard	N. American Design Standard	Qty.
ERBG-06	M10 × 70 Lg.	3/8 - 16 UNC × 2-3/4 Lg.	4
ERBG-10	M10 × 70 Lg.	3/8 - 16 UNC × 2-3/4 Lg.	6

■ Applicable Power Amplifier

For stable performance, it is recommended that Yuken's applicable power amplifiers be used (for details see [page 767, 771, 780](#)).

- Model Numbers : AME-D-10-\*-20
- AME-D2-1010-11
- SK1022- \*- \*-11
- SK1015-11 (For DC power supply)
- AMN-D-10 (For DC power supply)

■ Sub-plate

Valve Model Numbers	Japanese Standard "JIS"		European Design Standard		N. American Design Standard		Approx. Mass kg (lbs.)
	Sub-plate Model Numbers	Thread Size	Sub-plate Model Numbers	Thread Size	Sub-plate Model Numbers	Thread Size	
ERBG-06	ERBGM-06-20	Rc 3/4	ERBGM-06-2080	3/4 BSP.F	ERBGM-06-2090	3/4 NPT	3.0 (6.6)
ERBG-10	ERBGM-10-10	Rc 1-1/4	ERBGM-10-1080	1-1/4 BSP.F	ERBGM-10-1090	1-1/4 NPT	6.5 (14.3)

● Sub-plates are available. Specify the sub-plate model number from the table above. When sub-plates are not used, the mounting surface should have a good machined finish.

■ Instructions

● Primary Pressure Required for Preselected Pressure

The primary pressure must be 1 MPa (145 PSI) higher than the preselected pressure.

● Drain Back Pressure

Check that the drain back pressure does not exceed 0.2 MPa (29 PSI).

● Trapped Oil Volume

The recommended secondary side trapped oil volume is about 20 liters (5.28 U.S.Gallons). Note that the trapped oil volume must not be lower than 1.4 liters (.37 U.S.Gallons).

ERBG-06-\*/-51/5190

DIMENSIONS IN  
MILLIMETRES (INCHES)

The direction can be altered  
to every 90 degree angles.

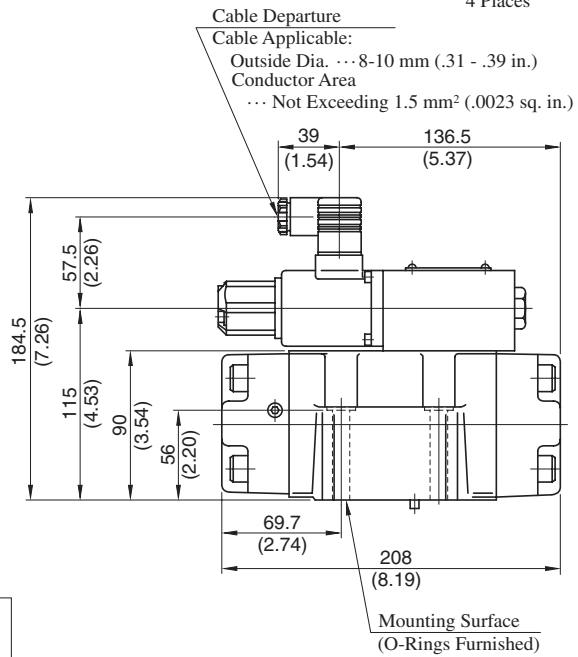
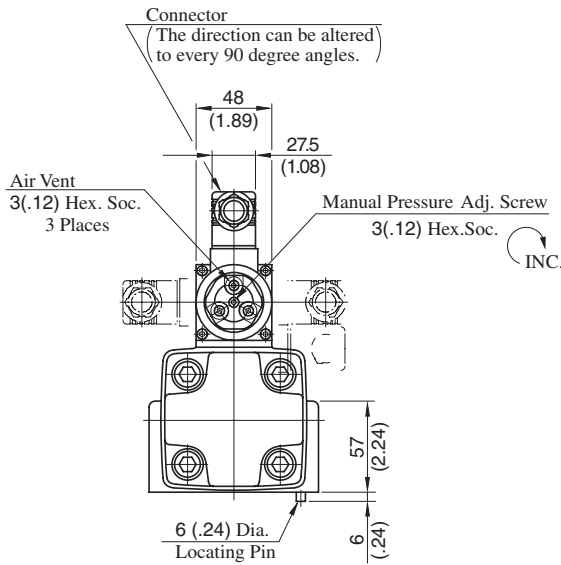
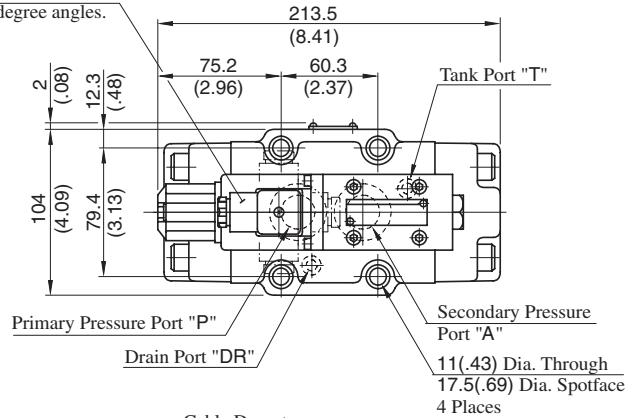

Sub-plate:

ERBGM-06-20/2080/2090

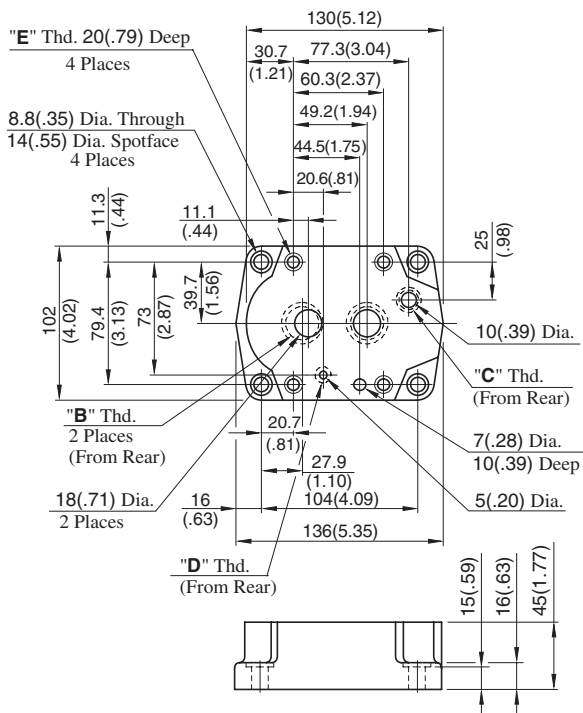

Sub-plate Model Numbers	Thread Size			
	"B" Thd.	"C" Thd.	"D" Thd.	"E" Thd.
ERBGM-06-20	Rc 3/4	Rc 3/8	Rc 1/4	M10
ERBGM-06-2080	3/4 BSP.F	3/8 BSP.F	1/4 BSP.F	
ERBGM-06-2090	3/4 NPT	3/8 NPT	1/4 NPT	

**ERBG-10-\*-51/5190**

**DIMENSIONS IN MILLIMETRES (INCHES)**

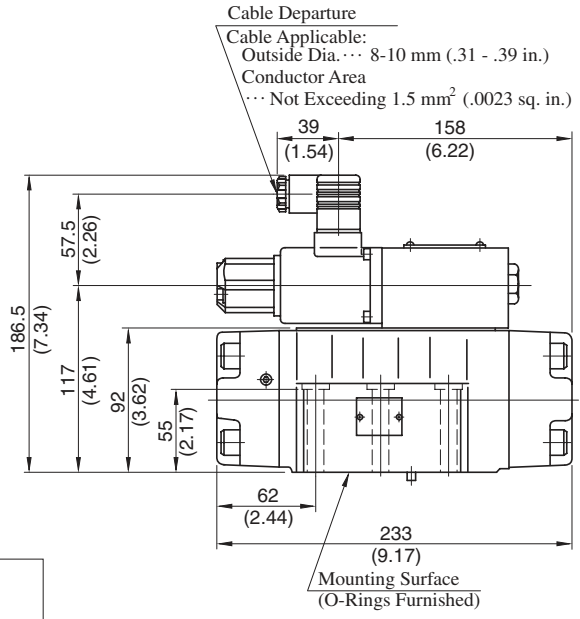
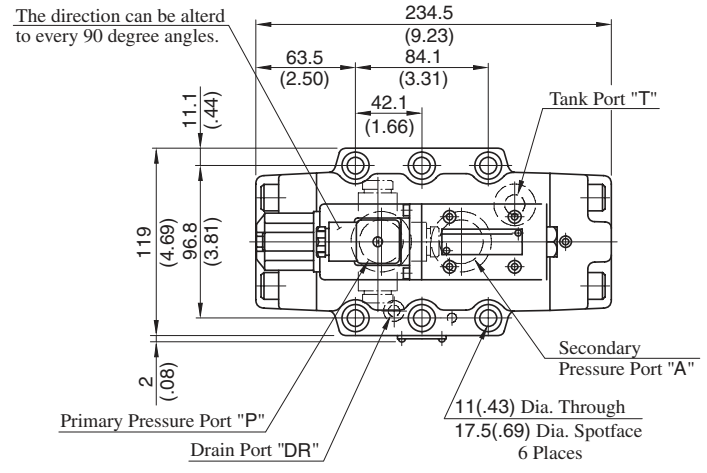
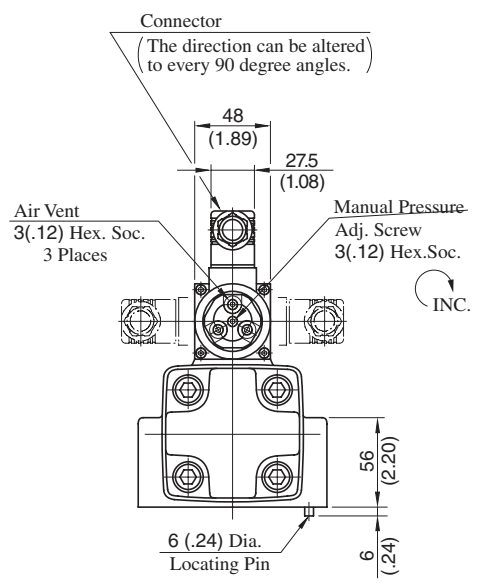

**Sub-plate ERBGM-10-10/1080/1090**

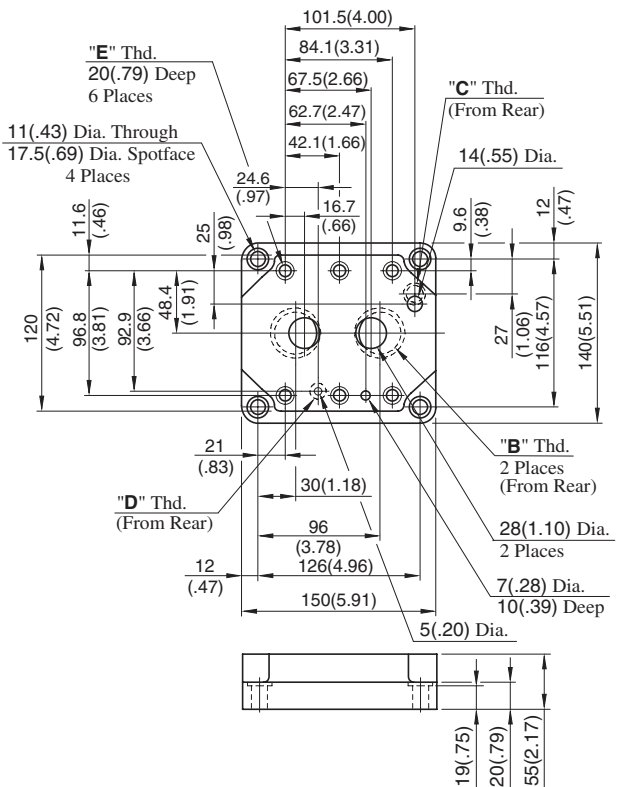

Sub-plate Model Numbers	Thread Size			
	"B" Thd.	"C" Thd.	"D" Thd.	"E" Thd.
ERBGM-10-10	Rc 1-1/4	Rc 3/8	Rc 1/4	M10
ERBGM-10-1080	1-1/4 BSP.F	3/8 BSP.F	1/4 BSP.F	
ERBGM-10-1090	1-1/4 NPT	3/8 NPT	1/4 NPT	3/8-16 UNC

**Step Response (Example)**

The following step response characteristics are taken when the trapped oil volume is 20 liters (5.28 U.S.Gallons). The step response varies by trapped oil volume.

Primary Pressure : 24.5 MPa (3550 PSI)  
 Trapped Oil Volume : 20 L (5.28 U.S.Gallons)  
 Viscosity : 30 mm<sup>2</sup>/s (141 SSU)

**ERBG-06-B**

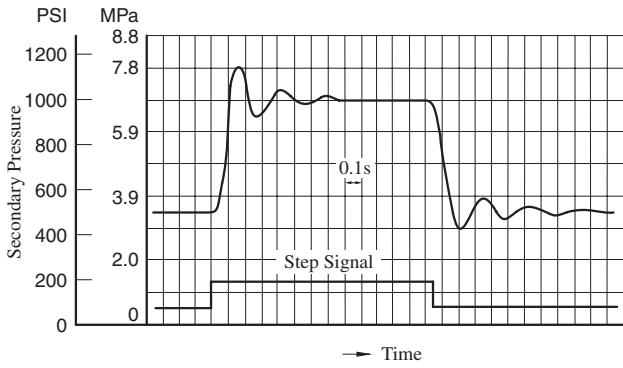

**ERBG-10-B**

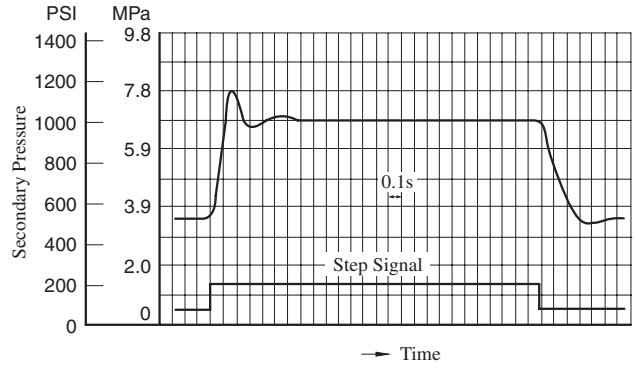

**ERBG-06-C**

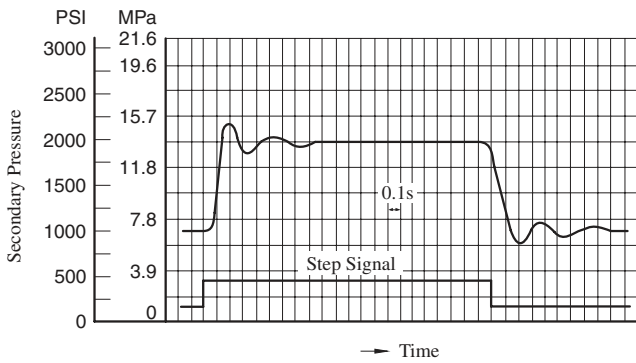

**ERBG-10-C**

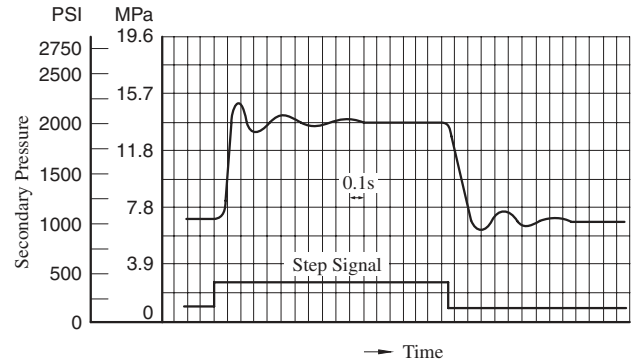

**ERBG-06-H**

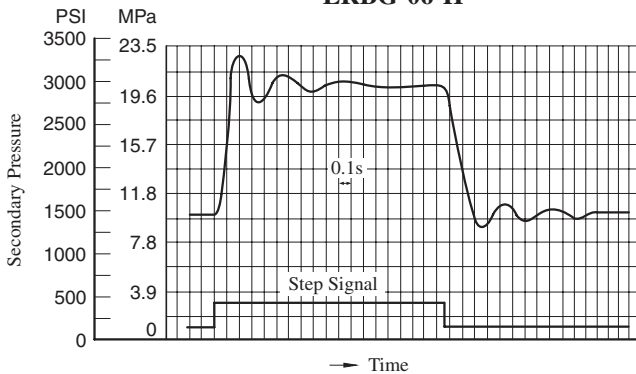

**ERBG-10-H**

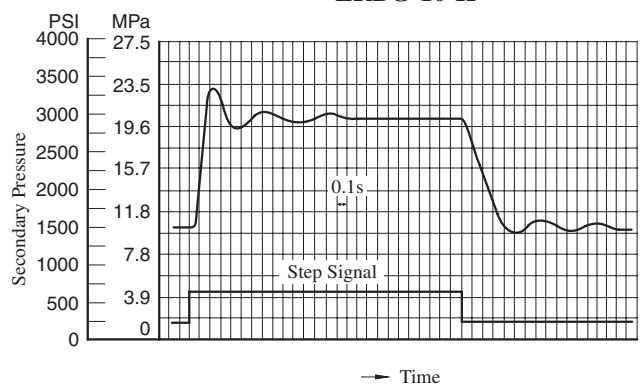

**Input Current vs. Secondary Pressure**

Primary Pressure : 24.5 MPa (3550 PSI)  
 Viscosity : 30 mm<sup>2</sup>/s (141 SSU)

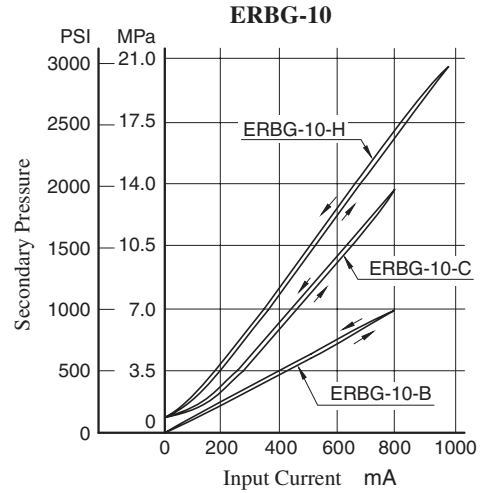
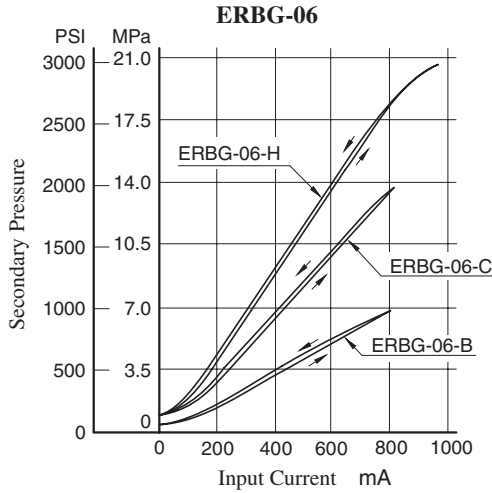

**Frequency Response**

Primary Pressure : 24.5 MPa (3550 PSI)  
 Trapped Oil Volume : 20 L (5.28 U.S.Gallons)  
 Viscosity : 30 mm<sup>2</sup>/s (141 SSU)

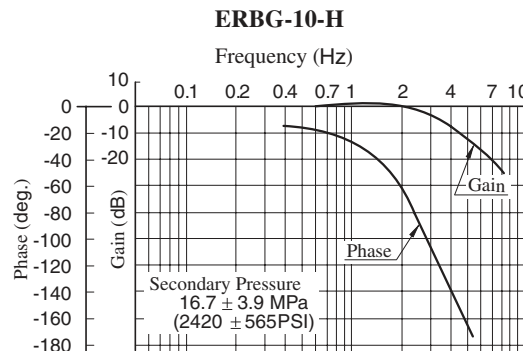
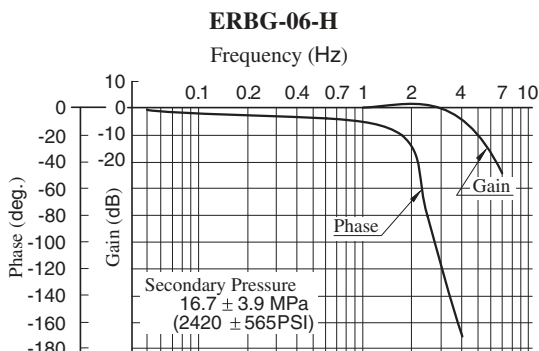
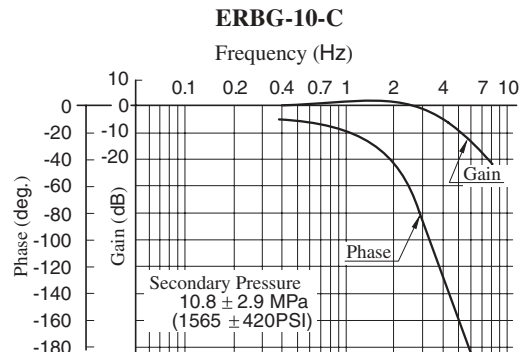
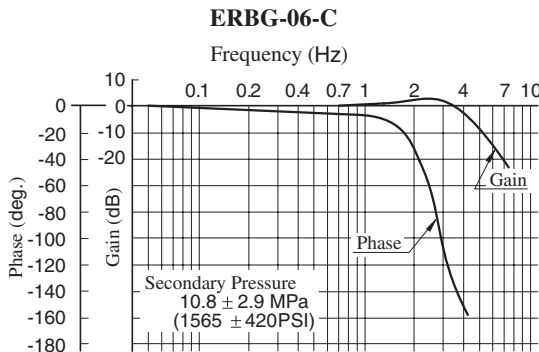
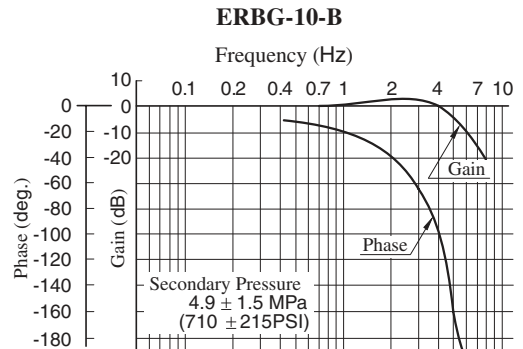
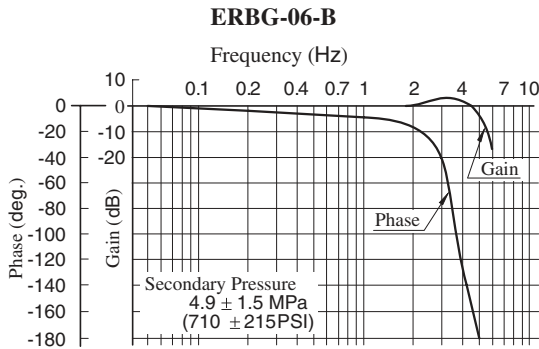

**Flow Rate vs. Secondary Pressure**

Viscosity : 30 mm<sup>2</sup>/s (141 SSU)

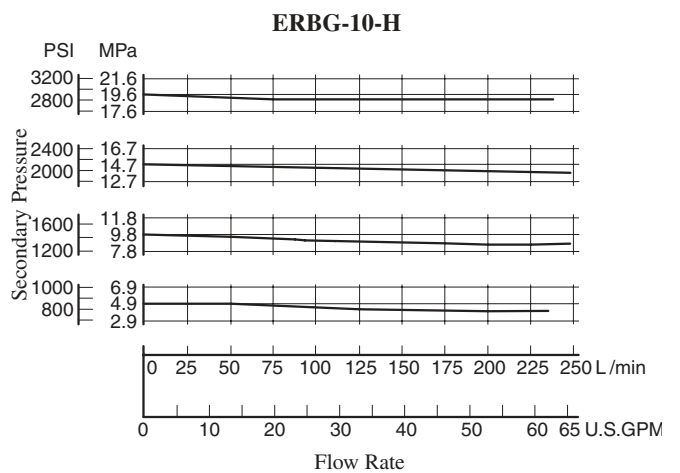
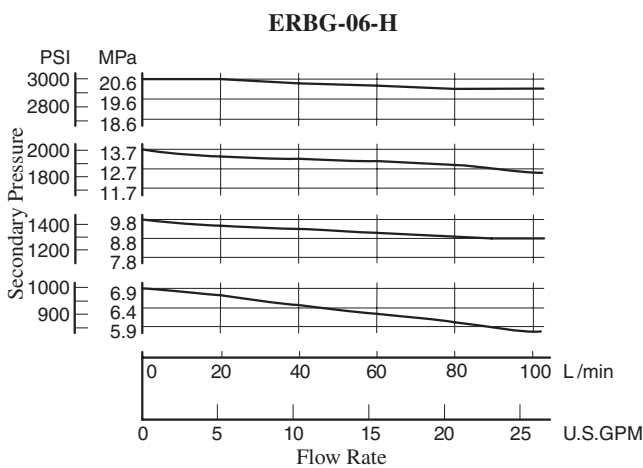
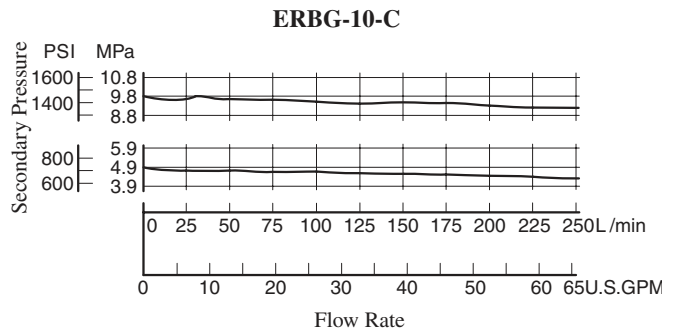
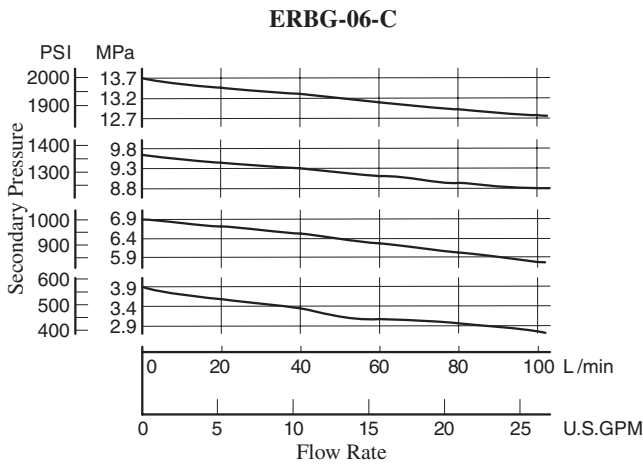
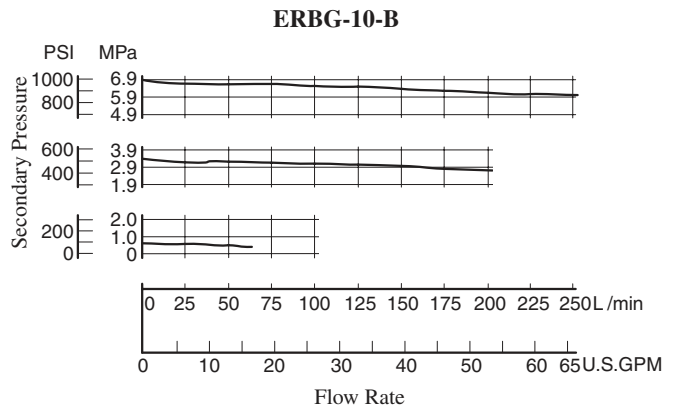
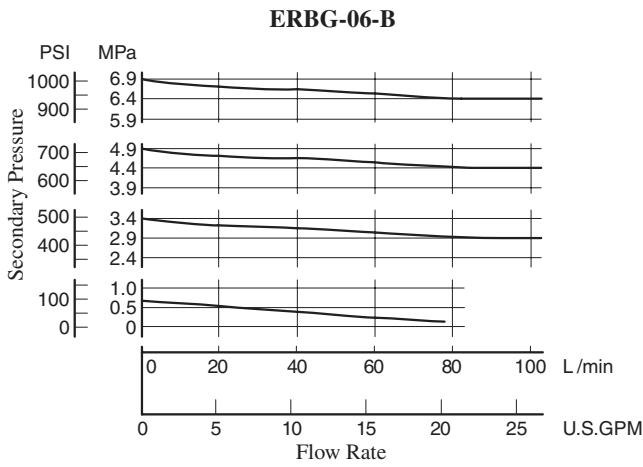

**H**  
E Series  
Relieving and Reducing Valves

■ Viscosity vs. Secondary Pressure

Oil: ISO VG32

**ERBG-06-B**

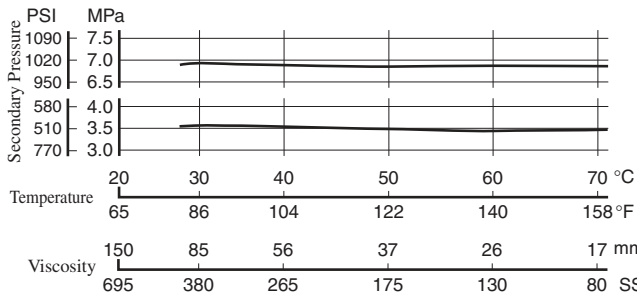

**ERBG-10-B**

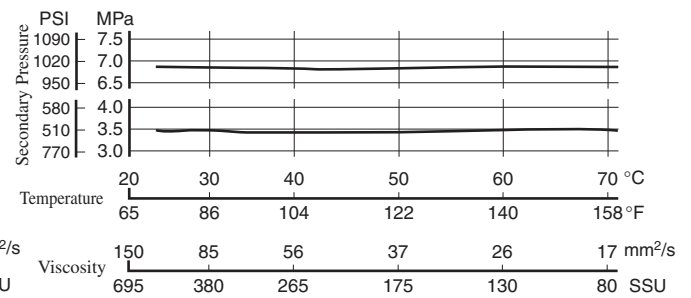

**ERBG-06-C**

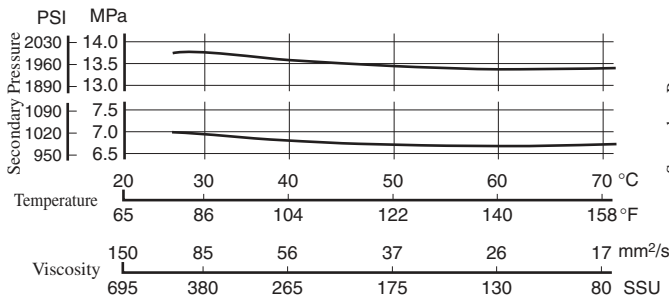

**ERBG-10-C**

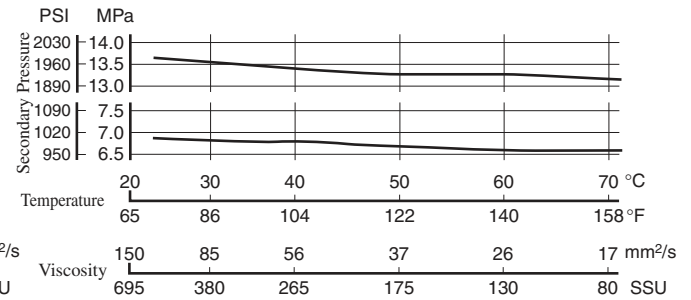

**ERBG-06-H**

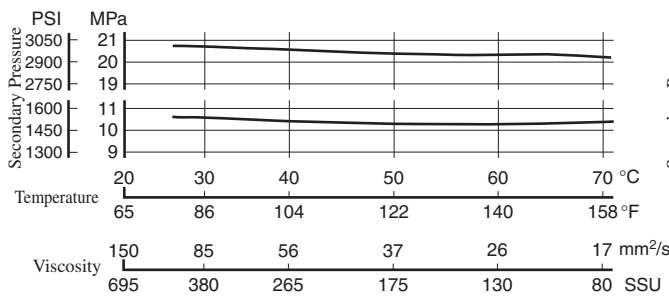

**ERBG-10-H**

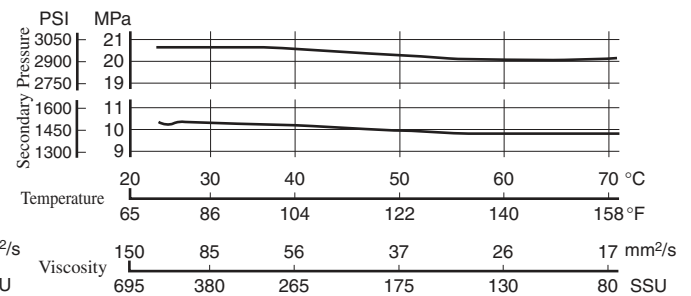



**List of Seals and Pilot Valves**

ERBG- $\frac{06}{10}$ -\*-51/5190

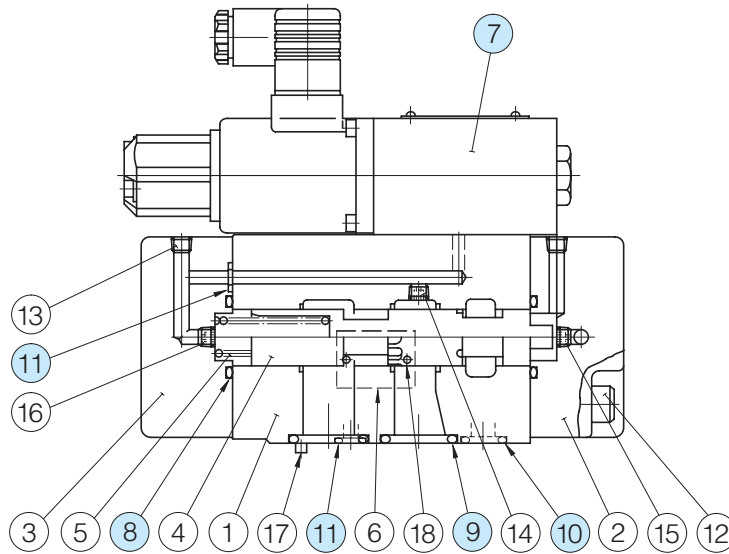

**List of Seals**

Item	Name of Parts	Part Numbers		Qty.
		ERBG-06	ERBG-10	
8	O-Ring	SO-NB-G30	SO-NB-P36	2
9	O-Ring	SO-NB-P28	SO-NB-P32	2
10	O-Ring	SO-NB-P14	SO-NB-P18	1
11	O-Ring	SO-NB-P9	SO-NB-P9	3

Note) When ordering seals, please specify the seal kit number from the table below. In addition to the above O-rings, seals for pilot valve are included in the seal kit.  
For the details of the pilot valve seals, see [page 674](#).

**List of Seal Kits**

Valve Model Numbers	Seal Kit Numbers
ERBG-06	KS-ERBG-06-51
ERBG-10	KS-ERBG-10-51

**Pilot Valve**

Valve Model No.	⑦ Pilot Valve Model Numbers
ERBG-06-B-51/5190	EDG-01-B-PNTN-5101
ERBG-06-C-51/5190	EDG-01-C-PNTN-5101
ERBG-06-H-51/5190	EDG-01-H-PNT15-5101
ERBG-10-B-51/5190	EDG-01-B-PNTN-5101
ERBG-10-C-51/5190	EDG-01-C-PNTN-5101
ERBG-10-H-51/5190	EDG-01-H-PNT15-5101

Note: For the details of pilot valves, refer to "Pilot Relief Valves" on [page 674](#).

■ **Interchangeability between Current and New Design**

ERBG-06/10 series valves have changed model from 50 to 51 design in line with the model change of pilot valve (EDG-01).

● **Specifications and Characteristics**

No change in specifications and characteristics between current and new design.

● **Mounting Interchangeability**

There is an interchangeability in the mounting dimensions, however, the outside shape and dimensions are changed as shown below due to pilot valve improvement and other modifications.

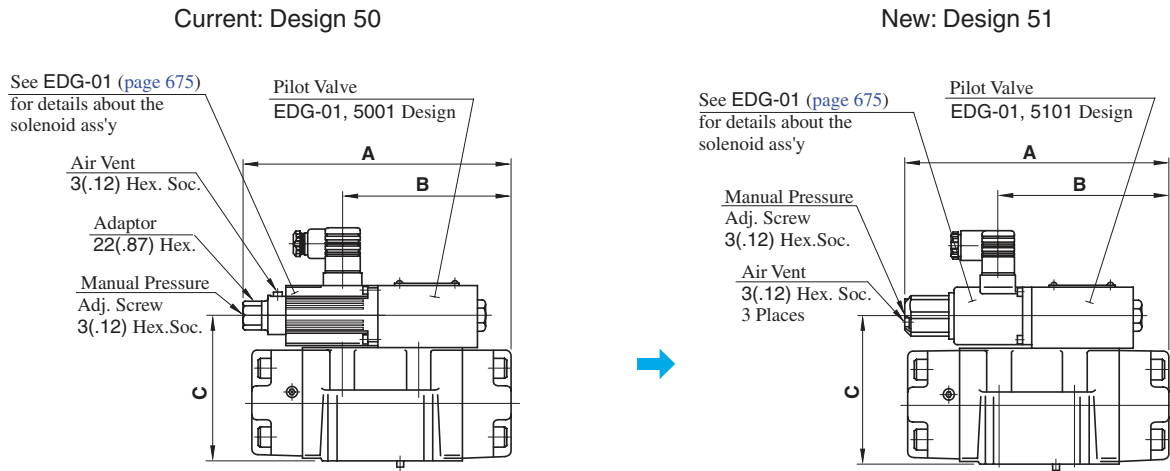

Model Numbers		A	B	C
Current	ERBG-06-*-50/5090	214.5 (8.44)	136.5 (5.37)	115 (4.53)
New	ERBG-06-*-51/5190	213.5 (8.41)	136.5 (5.37)	115 (4.53)
Current	ERBG-10-*-50/5090	235.5 (9.27)	158 (6.22)	117 (4.61)
New	ERBG-10-*-51/5190	234.5 (9.23)	158 (6.22)	117 (4.61)

**DIMENSIONS IN  
MILLIMETRES (INCHES)**