

## Shockless Type Proportional Electro-Hydraulic Directional and Flow Control Valves

These valves are well accepted by industrial users as shifting time adjustable type shockless valves. By employing the basic design concept of the “G series solenoid operated directional valves”, we have been successful developing the shifting time adjustable shockless valves with high performance which makes the speed setting possible at any high speed operation.

In combination with the newly developed digital amplifiers, the further enhancement of maneuverability and repeatability of the valves can be realized.

### Specifications

Model No.		EDFG-01
Description		EDFG-01
Max. Operating Pressure	MPa (PSI)	25 (3630)
Max. Flow	L/min (U.S.GPM)	30 (7.9)
Max. Tank Line Back Pressure	MPa (PSI)	14 (2030)
Rated Current		1100 mA
Coil Resistance		10.8 Ω
Hysteresis		5% or less
Repeatability		1% or less
Step Response (Typical Rating) (0 ↔ 100%)		100 ms or less
Frequency Response (50% ±25%)	Phase	20 Hz (-90 degree)
	Gain	25 Hz (-3 dB)
Approx. Mass	kg (lbs.)	2.4 (5.3)

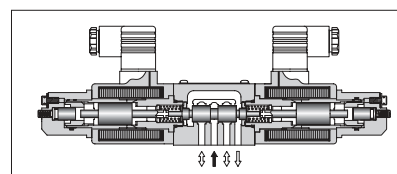
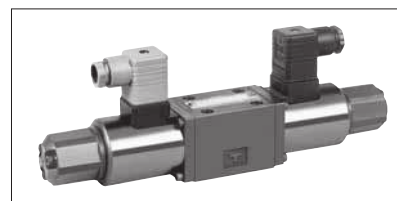

Graphic Symbols

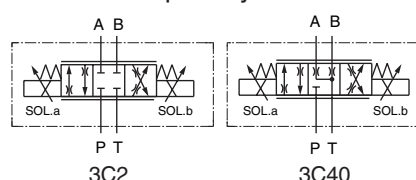

### Model Number Designation

F-	EDF	G	-01	-30	-3C2	-XY	-50	*
Special Seals	Series Number	Type of Mounting	Valve Size	Rated Flow L/min (U.S.GPM)	Spool Type	Direction of Flow	Design Number	Design Standards
<b>F:</b> Special Seals for Phosphate Ester Type Fluid (Omit if not required)	<b>EDF:</b> Shockless Type Proportional Directional and Flow Control Valve	<b>G:</b> Sub-plate Mounting	<b>01</b>	<b>30</b> (7.9)	<b>3C2</b> <b>3C40</b>	<b>XY:</b> Metre - In • Metre - Out	<b>50</b>	Refer to ★1

★1 Design Standards: None..... Japanese Standard "JIS" and European Design Standard 90 ..... N. American Design Standard

### Attachment

#### Mounting Bolts

Descriptions	Soc. Hd. Cap Screw	Qty.
Japanese Standard "JIS"	M5 × 45 Lg.	4
European Design Standard	M5 × 45 Lg.	4
N. American Design Standard	No.10 - 24 UNC × 1-3/4 Lg.	4

### Applicable Power Amplifier

For stable performance, it is recommended that Yuken's applicable power amplifiers be used (for details see page 782).

Model Numbers: AMN-G/W-10

### Sub-plate

Piping Size	Japanese Standard "JIS"		European Design Standard		N. American Design Standard		Approx. Mass kg (lbs.)
	Sub-plate Model Numbers	Thread Size	Sub-plate Model Numbers	Thread Size	Sub-plate Model Numbers	Thread Size	
1/8	DSGM-01-31	Rc 1/8	DSGM-01-3180	1/8 BSP.F	DSGM-01-3190	1/8 NPT	0.8 (1.8)
1/4	DSGM-01X-31	Rc 1/4	DSGM-01X-3180	1/4 BSP.F	DSGM-01X-3190	1/4 NPT	0.8 (1.8)
3/8	DSGM-01Y-31	Rc 3/8	—	—	DSGM-01Y-3190	3/8 NPT	0.8 (1.8)

● Sub-plates are available. Specify the sub-plate model number from the table above. When sub-plates are not used, the mounting surface should have a good machined finish.

● Sub-plates are those for 1/8 solenoid operated directional valves. For dimensions, see page 356.

EDFG-01-30-3C\*-XY-50/5090

Mounting Surface  
ISO 4401-AB-03-4-A

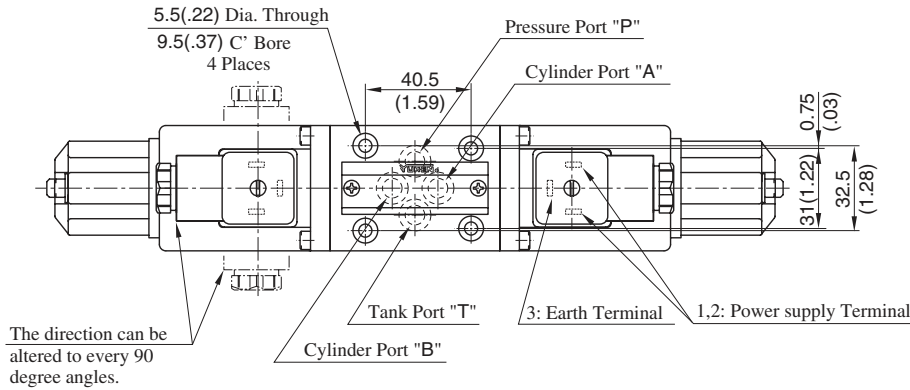

**DIMENSIONS IN MILLIMETRES (INCHES)**

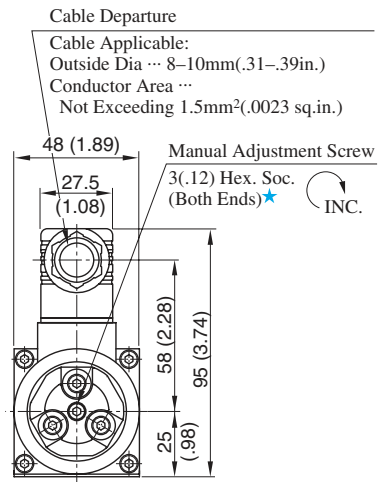
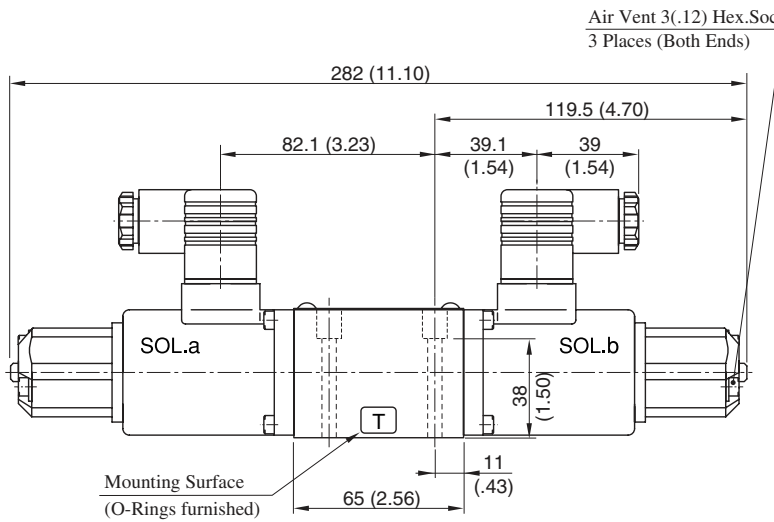

★ Under normal conditions, however, this screw must be kept in its original position.

■ Input Current vs. Flow

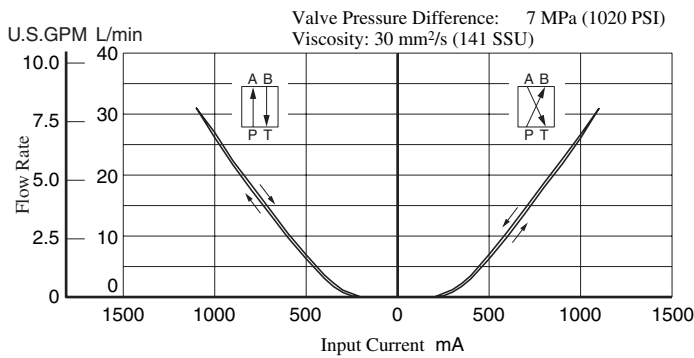

■ Valve pressure Difference vs. Flow

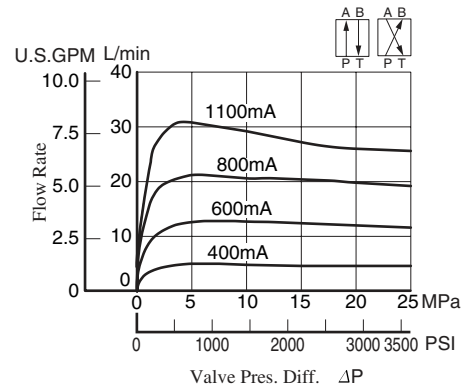

List of Seals and Solenoid Ass'y

EDFG-01-30-\*-XY-50/5090

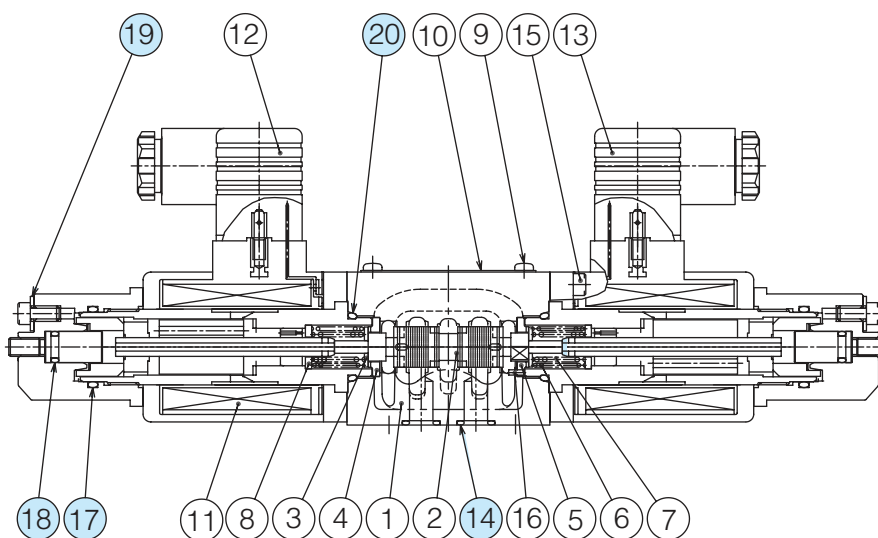

List of Seals

Item	Name of Parts	Part Numbers	Qty.	Remarks
14	O-Ring	SO-NB-P9	4	Included in Seal Kit
17	O-Ring	SO-NB-P22	2	
18	O-Ring	SO-NB-P7	2	
19	Fastner Seal	SG-FCF-4	6	Kit No.:
20	O-Ring	SO-NB-P18	2	KS-EDFG-01-50

Note) O-ring (Item 17, 18, 20) and the fastner sael (Item 19) are included in the solenoid assembly.

Solenoid Ass'y

Valve Model Numbers	⑪ Solenoid Ass'y	Qty.
EDFG-01-30-*-XY-50/5090	E318-Y05M2-28-6103	2

Note) The connector assembly GDM-211-\*-11 (Item 12, 13) is not included in the solenoid assembly.