

## ■ Proportional Electro-Hydraulic Directional and Flow Control Valves

These valves are double-deck directional and flow control valves employing as their pilot the electro-hydraulic proportional pressure reducing valves with two proportional solenoids. The flow rate can be controlled by changing an input current to the solenoids and the direction of the flow can be controlled by providing the current to either solenoid of the two.

By combining the valves with the power amplifiers specially designed for the valves, the speed control, acceleration, deceleration and directional control can be done with a single valve, which eventually makes the hydraulic circuits simple and contributes the cost of the hydraulic systems.

### ■ Specifications

Model No.		EDFHG-03	EDFHG-04	EDFHG-06
Description				
Max. Operating Pressure	MPa (PSI)	25 (3630)		
Rated Flow	L/min (U.S.GPM)	100 (26.4)	140 (37.0)	280 (74.0)
at Valve Pressure Difference: 1.0 MPa (145 PSI)				
Pilot Pressure <sup>★1</sup>	MPa (PSI)	1.5 - 16 (220 - 2320) <sup>★1</sup>		
Pilot Flow	at Normal	1 (.26)	1 (.26)	1 (.26)
	L/min (U.S.GPM) at Transition	3 (.79)	4 (1.06)	6 (1.59)
Max. Tank Line Back Pressure	MPa (PSI)	16 (2320)	21 (3050)	21 (3050)
Max. Drain Line Back Pressure	MPa (PSI)	3.0 (435) <sup>★2</sup>		
Rated Current		800 mA	980 mA	900 mA
Coil Resistance		10 Ω		
Hysteresis		5% or less <sup>★3</sup>		
Repeatability		1% or less <sup>★3</sup>		
Approx. Mass	kg (lbs.)	11 (24.3)	12 (26.5)	15 (33.1)

★1. Take care to keep the difference between the pilot pressure and drain port back pressure consistently greater than 1.5 MPa (220 PSI).

★2. To obtain stable performance, keep the drain port back pressure low and minimize its fluctuations.

★3. The hysteresis and repeatability values indicated in the specifications for each control valve are determined under the following conditions:

- Hysteresis Value: Obtained when Yuken's applicable power amplifier is used.
- Repeatability Value: Obtained when Yuken's applicable power amplifier is used under the same conditions.

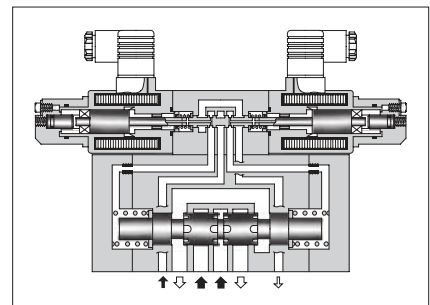
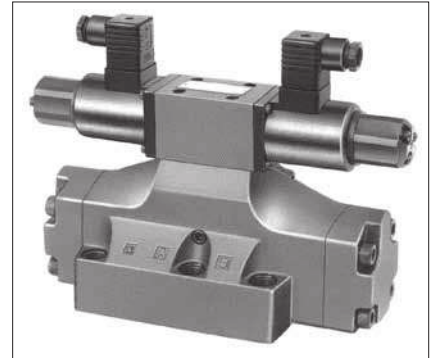

Graphic Symbols

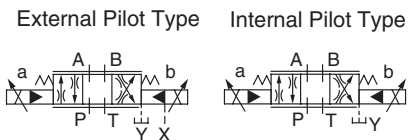

### ■ Model Number Designation

F-	EDFH	G	-03	-100	-3C2	-XY	-E	-31	*
Special Seals	Series Number	Type of Mounting	Valve Size	Rated Flow L/min (U.S.GPM)	Spool Type <sup>★1</sup>	Direction of Flow	Pilot Connection	Design Number	Design Standards
<b>F:</b> Special Seals for Phosphate Ester Type Fluids (Omit if not required)	<b>EDFH:</b> Proportional Electro-Hydraulic Directional and Flow Control Valves	<b>G:</b> Sub-Plate Mounting	<b>03</b> <b>04</b> <b>06</b>	<b>100:</b> 100 (26.4) <b>140:</b> 140 (37.0) <b>280:</b> 280 (74.0)	<b>3C2</b> <b>3C40</b>	<b>XY:</b> Metre-in • Metre-out	<b>E:</b> External Pilot <b>None:</b> Internal Pilot	<b>31</b> <b>31</b> <b>31</b>	Refer to <sup>★2</sup>

★1. Spool type shown in the column is for the centre position.

★2. Design Standards: None ..... Japanese Standard "JIS" and European Design Standard 90 ..... N. American Design Standard

### ■ Attachment

#### ● Mounting Bolts

Model Numbers	Socket Head Cap Screw			
	Japanese Standard "JIS" European Design Standard	N. American Design Standard	Qty.	Tightening Torque Nm (in. lbs.)
EDFHG-03	M6 × 35 Lg.	1/4-20 UNC × 1-1/2 Lg.	4	12 - 15 (106 - 133)
EDFHG-04	M6 × 45 Lg.	1/4-20 UNC × 1-3/4 Lg.	2	12 - 15 (106 - 133)
	M10 × 50 Lg.	3/8-16 UNC × 2 Lg.	4	58 - 72 (513 - 637)
EDFHG-06	M12 × 60 Lg.	1/2-13 UNC × 2-1/2 Lg.	6	100 - 123 (885 - 1089)

## Sub-plates

Valve Model Numbers	Japanese Standard "JIS"			European Design Standard			N. American Design Standard		
	Sub-plate Model Numbers	Thread Size	Approx. Mass kg (lbs.)	Sub-plate Model Numbers	Thread Size	Approx. Mass kg (lbs.)	Sub-plate Model Numbers	Thread Size	Approx. Mass kg (lbs.)
EDFHG-03	DHGM-03Y-10	Rc 3/4	4.7 (10.4)	DHGM-03Y-1080	3/4 BSPF	4.7 (10.4)	DHGM-03Y-1090	3/4 NPT	4.7 (10.4)
EDFHG-04	DHGM-04-20	Rc 1/2	4.4 (9.7)	DHGM-04-2080	1/2 BSPF	4.4 (9.7)	DHGM-04-2090	1/2 NPT	4.4 (9.7)
	DHGM-04X-20	Rc 3/4	4.1 (9.0)		3/4 BSPF	4.1 (9.0)		3/4 NPT	4.1 (9.0)
EDFHG-06	DHGM-06-50	Rc 3/4	7.4 (16.3)	DHGM-06-5080	3/4 BSPF	8.5 (18.7)	DHGM-06-5090	3/4 NPT	7.4 (16.3)
	DHGM-06X-50	Rc 1	7.4 (16.3)		1 BSPF	8.5 (18.7)		1 NPT	7.4 (16.3)

- Sub-plates are available. Specify the sub-plate model number from the table above. When sub-plates are not used, the mounting surface should have a good machined finish.
- Sub-plates are those for solenoid controlled pilot operated directional valves. For dimensions, see [page 401 and 402](#).

## Applicable Power Amplifiers

For stable performance, it is recommended that Yuken's applicable power amplifiers be used (for details see [page 784](#)).

Model Numbers: SK1091-D24-10

## Instructions

### Manual Adjustment

In the event of an electric fault or emergency, a manual shift can be made by screwing in the manual adjustment screw. Take care, however, that this manual shift has no flows adjusting function.

For this operation, set the pilot pressure (or P-port pressure on an internal-pilot model) below 7 MPa (1020 PSI).

After operation, be sure to return the manual adjustment screw completely to the original position.

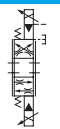

**EDFHG-03-100-3C\*-XY-\*-31/3190**

Mounting Surface: Main port ... Conform to ISO 4401-AC-05-4-A.  
Pilot/drain ports ... Conform to ISO.

★ Of the two tank ports "T", the tank port in the left side is normally used in our standard sub-plate, though, either side of the tank port "T" can be used without problem.

Note: For valve mounting surface dimensions, see the dimensional drawings of sub-plates (p.401) in common use.

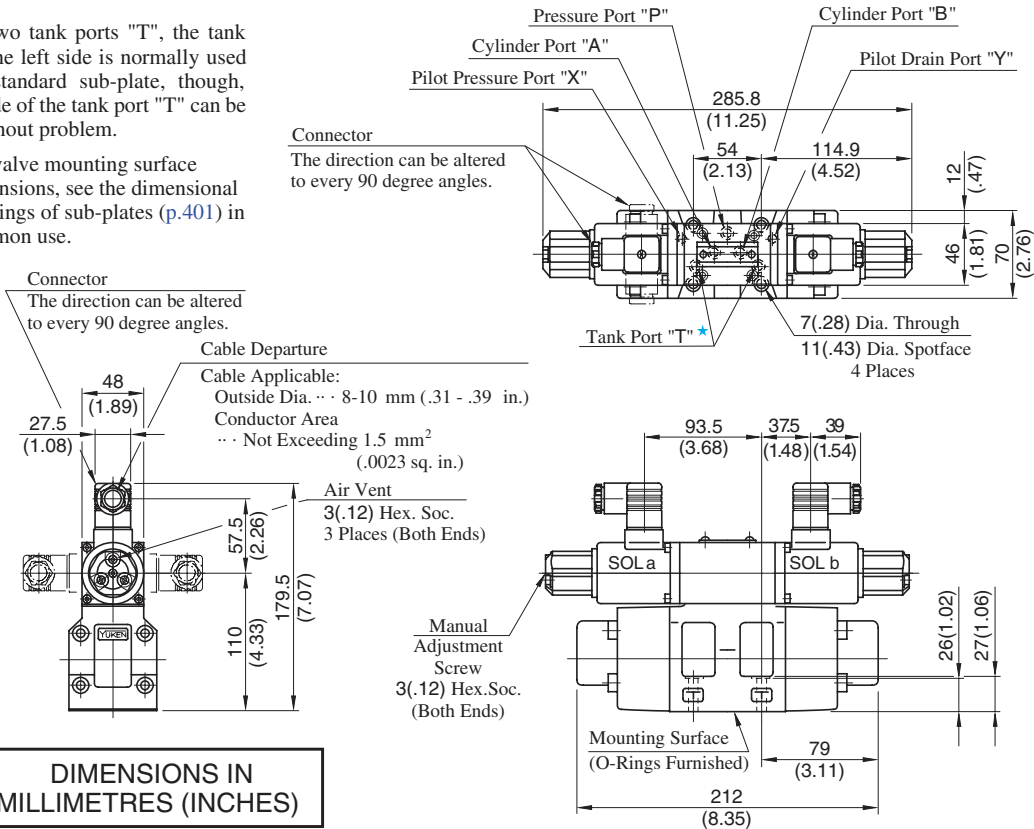

**DIMENSIONS IN MILLIMETRES (INCHES)**

**EDFHG-04-140-3C\*-XY-\*-31/3190**

Mounting surface: Conform to ISO4401-AD-07-4-A.

★ Position of cable departure can be changed. For details, refer to above ED FHG-03.

Note: For valve mounting surface dimensions, see the dimensional drawings of sub-plates (p.401) in common use.

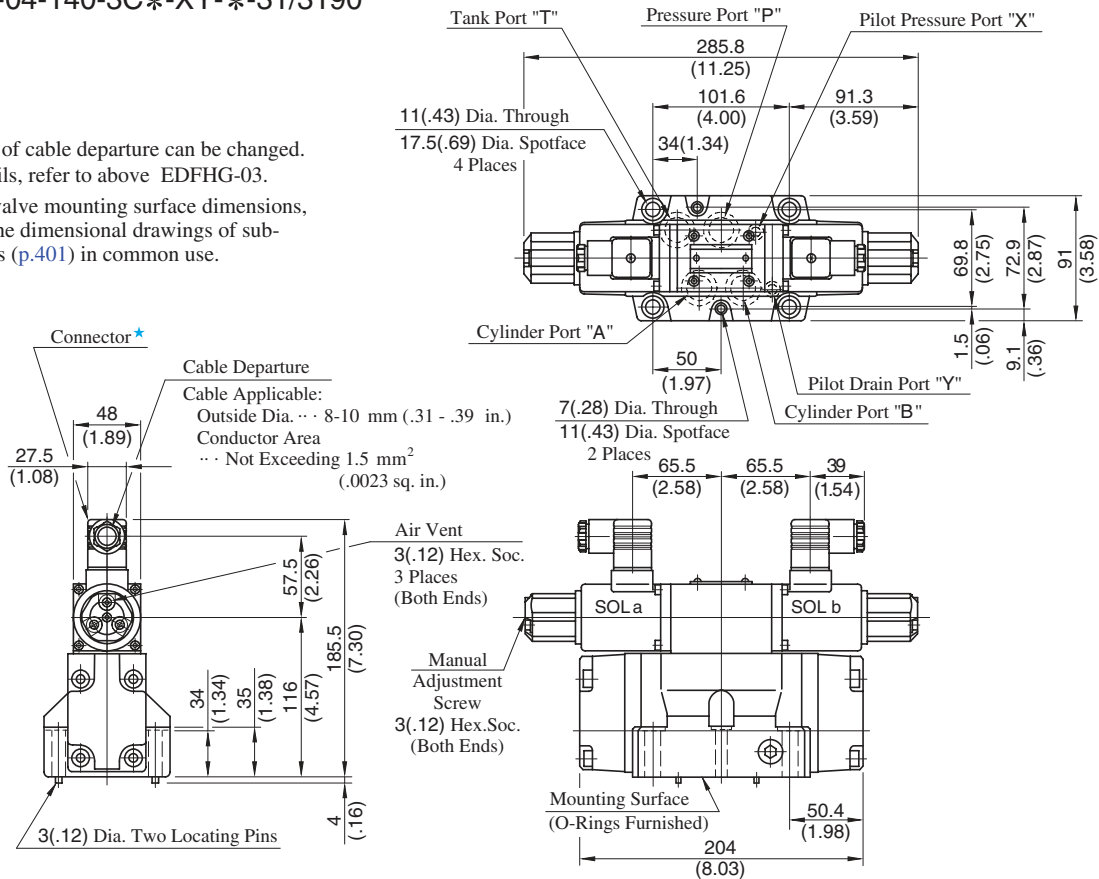

EDFHG-06-280-3C\*-XY-\*-31/3190

Mounting surface: Conform to ISO4401-AE-08-4-A.

★ Position of cable departure can be changed. For details, refer to EDFHG-03 valve on page 748.

Note: For valve mounting surface dimensions, see the dimensional drawings of sub-plates (p.402) in common use.

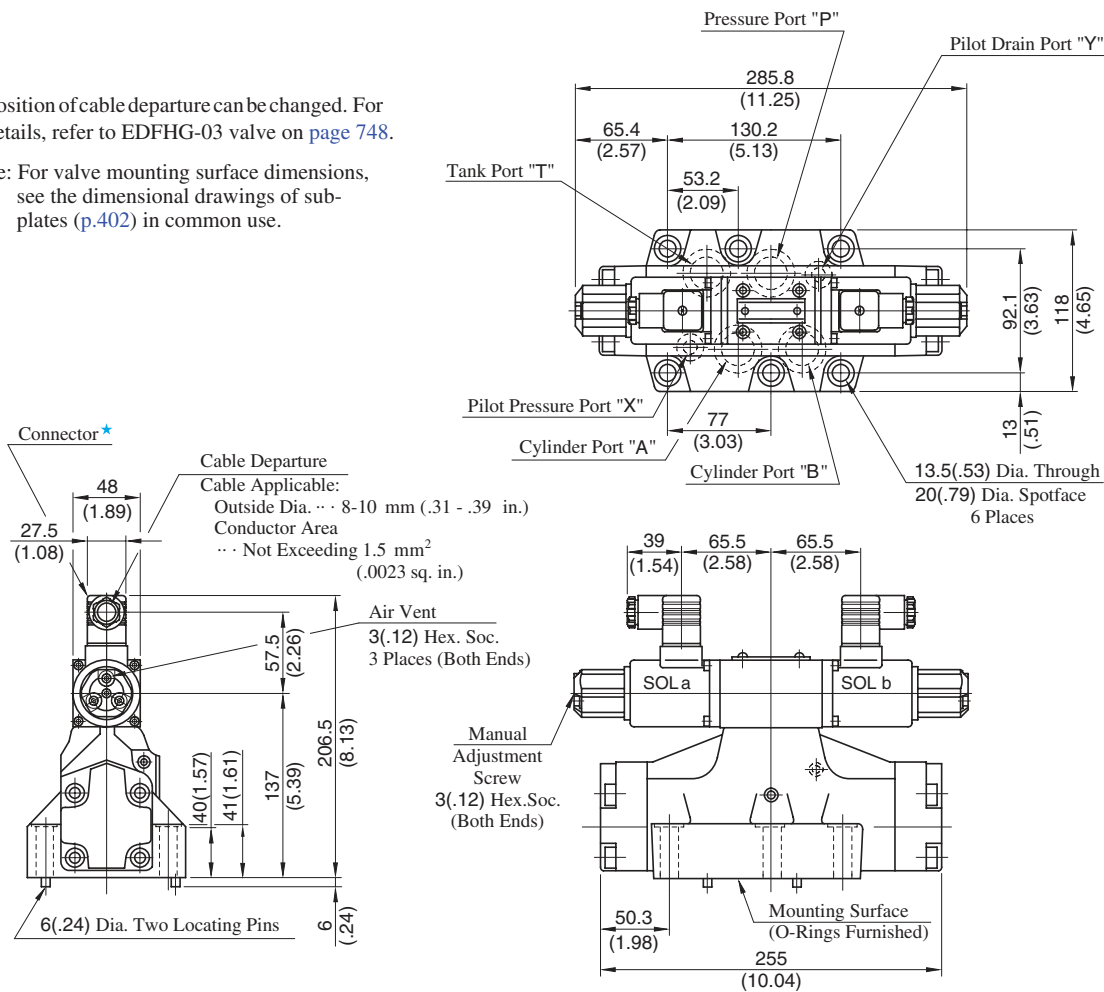

DIMENSIONS IN MILLIMETRES (INCHES)

■ Interchangeability between Current and New Design

● Specifications and Characteristics

No changes in specifications and characteristics between current and new design.

● Mounting Interchangeability

The mounting surface are interchangeable.

Note that because of improvements made on the solenoids, the overall shapes have been changed as shown below.

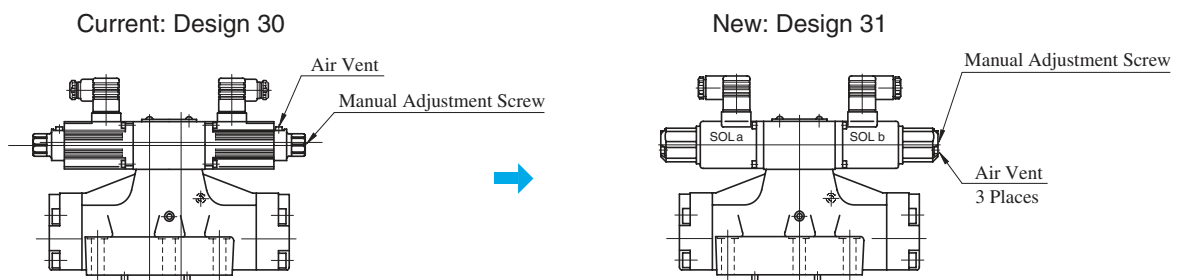

**H**  
E Series  
Directional and Flow Control Valves

**Input Current vs. Flow**

Viscosity : 30 mm<sup>2</sup>/s (141 SSU)

Valve Pres. Difference : P→A (B), B (A) →T 1 MPa (145 PSI)

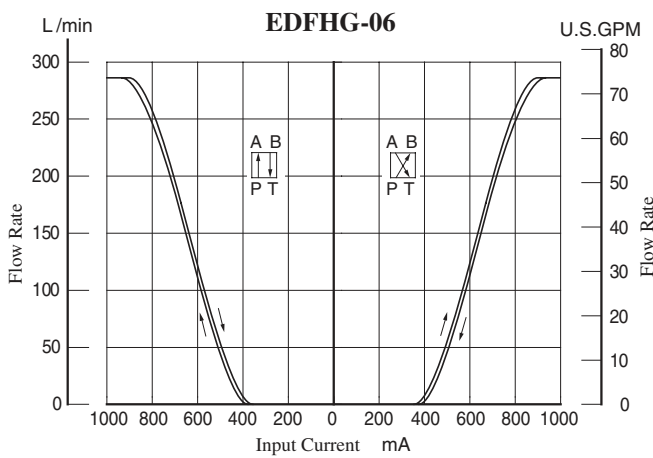
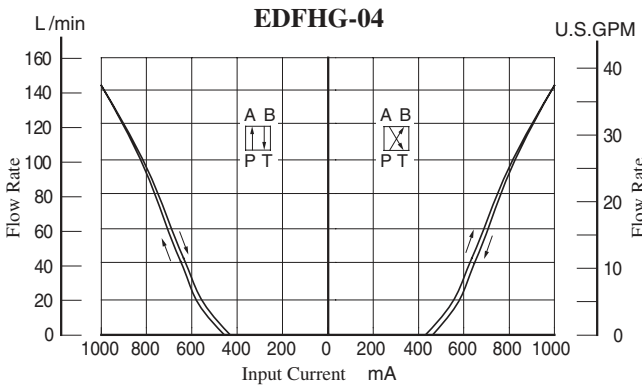
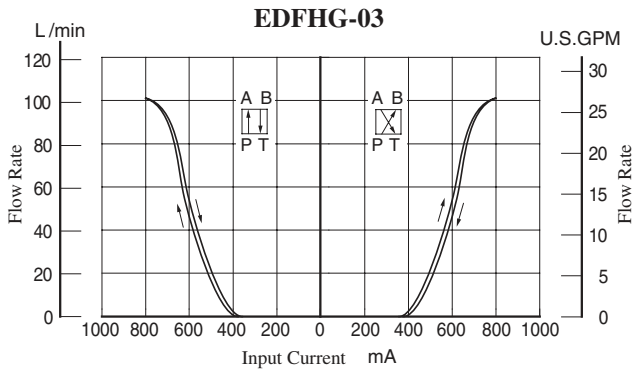

**Valve Pressure Difference vs. Flow**

Viscosity : 30 mm<sup>2</sup>/s (141 SSU)

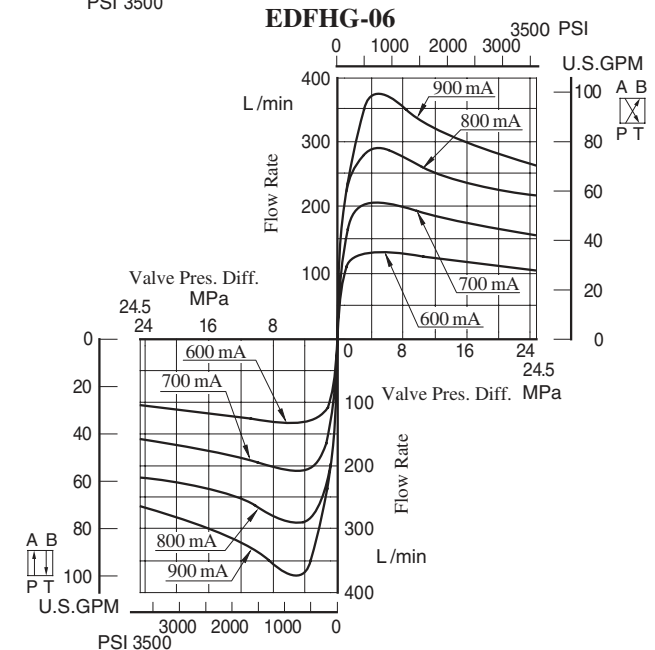
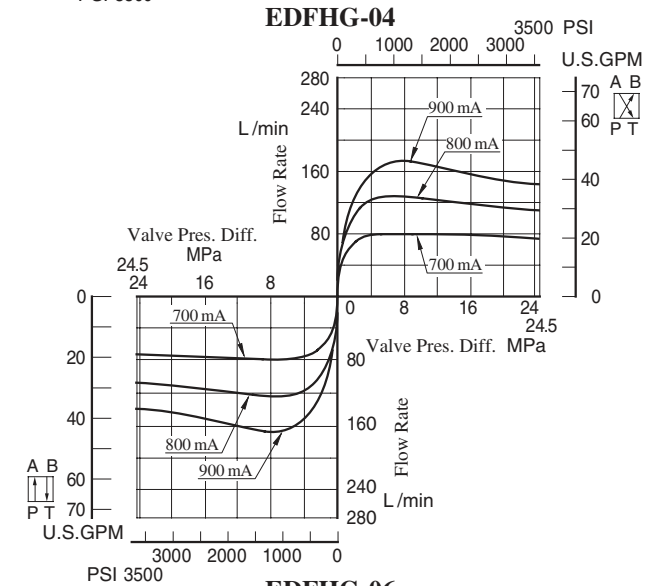
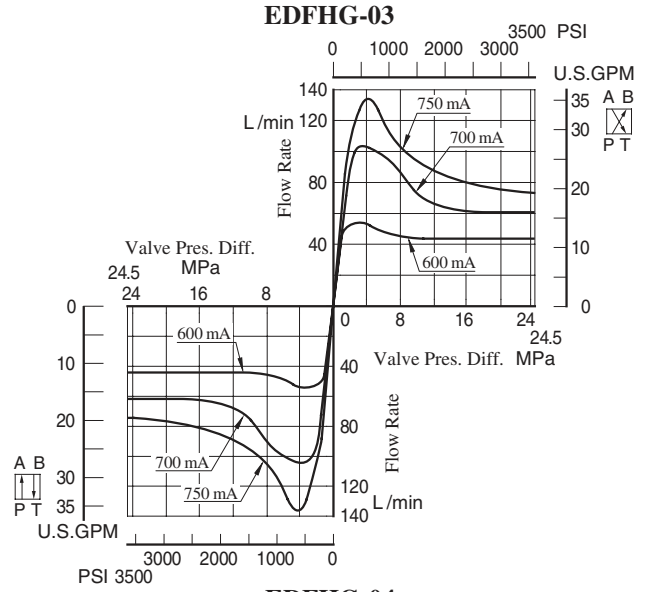

**Frequency Response**

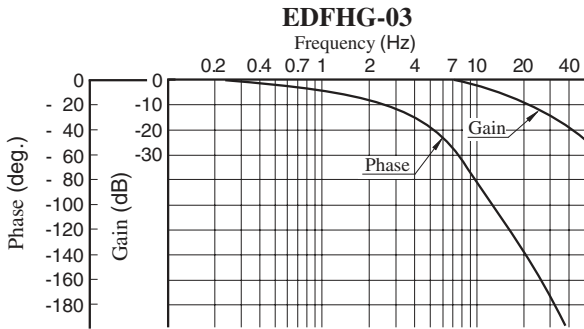

Model Number : EDFHG-03-100-3C2-E-31  
 Viscosity : 30 mm<sup>2</sup>/s(141 SSU)  
 Pilot Pressure : 15.7 MPa(2280 PSI)  
 Travel of Spool : ±10% of Maximum Stroke

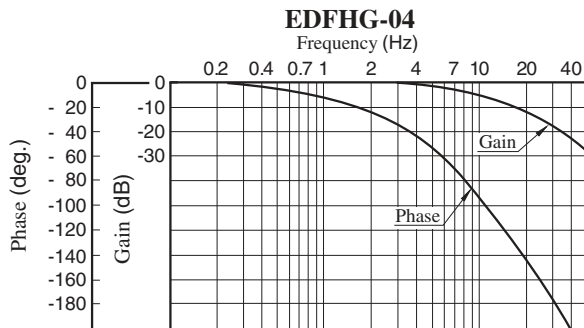

Model Number : EDFHG-04-140-3C2-E-31  
 Viscosity : 30 mm<sup>2</sup>/s(141 SSU)  
 Pilot Pressure : 15.7 MPa(2280 PSI)  
 Travel of Spool : ±10% of Maximum Stroke

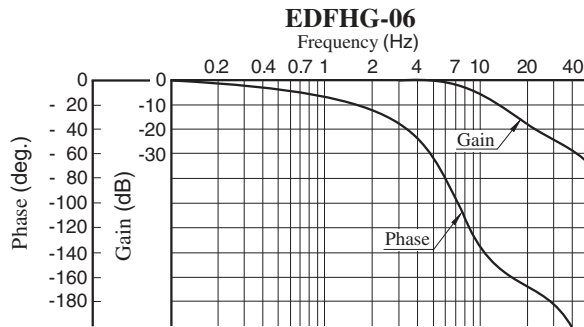

Model Number : EDFHG-06-280-3C2-E-31  
 Viscosity : 30 mm<sup>2</sup>/s(141 SSU)  
 Pilot Pressure : 15.7 MPa(2280 PSI)  
 Travel of Spool : ±10% of Maximum Stroke

**Step Response**

These characteristics have been obtained by measuring on each valve. Therefore, they may vary according to a hydraulic circuit to be used.

Viscosity : 30 mm<sup>2</sup>/s(141 SSU)  
 Supply Pressure : 15.7 MPa(2280 PSI)

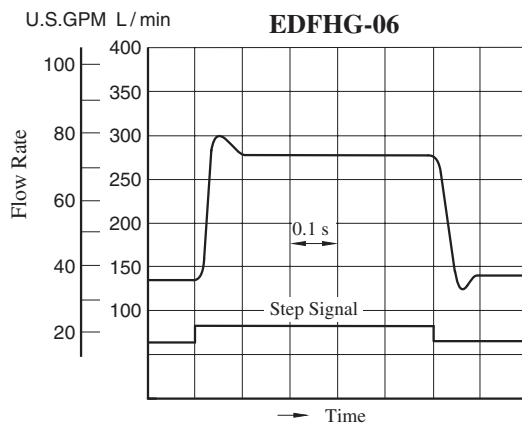
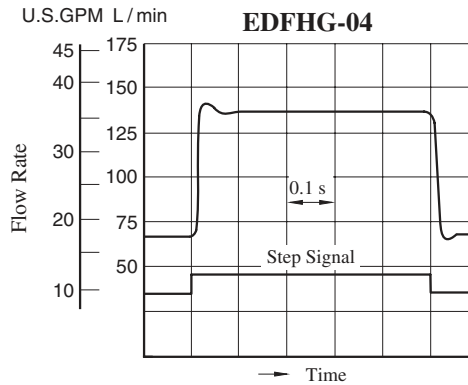
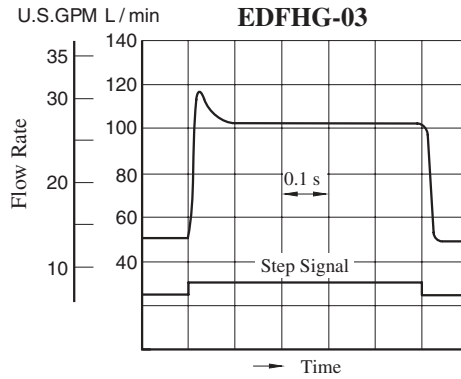

● List of Seals and Solenoid Ass'y

EDFHG-03-100-3C \*-XY- \*-31/3190  
 EDFHG-04-140-3C \*-XY- \*-31/3190  
 EDFHG-06-280-3C \*-XY- \*-31/3190

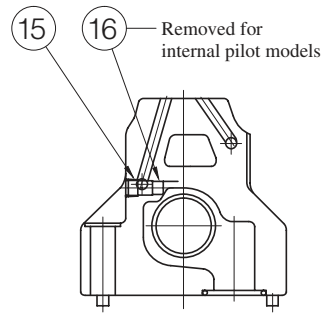
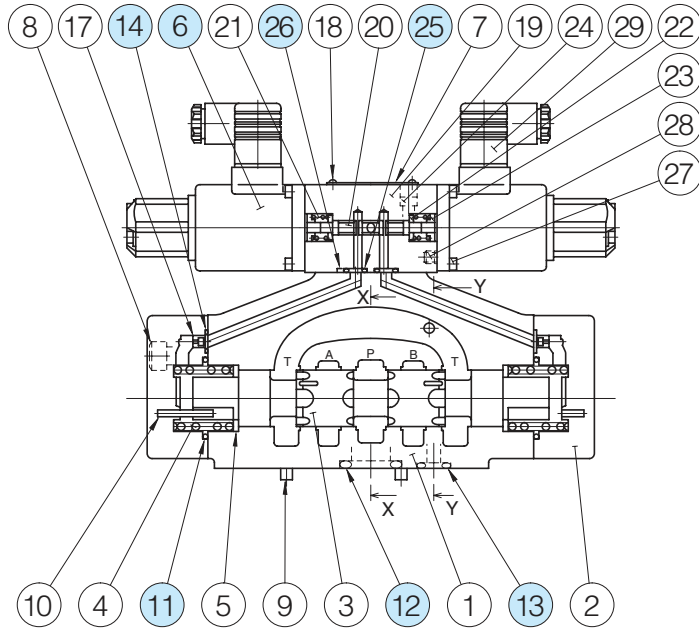

Section X-X

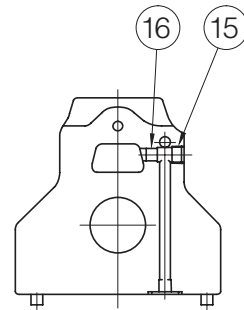

Section Y-Y

● List of Seals and Solenoid Ass'y

Item	Name of Parts	EDFHG-03		EDFHG-04		EDFHG-06	
		Part Numbers	Qty.	Part Numbers	Qty.	Part Numbers	Qty.
6	Solenoid Ass'y	E318-Y06M1-28-61	2	E318-Y06M1-28-61	2	E318-Y06M1-28-61	2
11	O-Ring	SO-NB-P28	2	SO-NB-P34	2	SO-NB-P40	2
12	O-Ring	SO-NB-A014	5	SO-NB-P22	4	SO-NB-P30	4
13	O-Ring	SO-NB-P9	2	SO-NB-P9	2	SO-NB-P14	2
14	O-Ring	SO-NB-P9	6	SO-NB-P9	2	SO-NB-P10	2
25	O-Ring	SO-NB-P9	4	SO-NB-P9	4	SO-NB-P9	4
26	O-Ring	SO-NB-P4	2	SO-NB-P4	2	SO-NB-P4	2

Note: The GDM-211-B-11 connector assembly (Item 29) is not included in the solenoid assembly.

When ordering seals, please specify the seal kit number from the table below. In addition to the above o-rings, seals for solenoid ass'y are included in the seal kit.

For the detail of the solenoid ass'y o-rings, see [page 674](#).

● List of Seal Kits

Valve Model Numbers	Seal Kit Numbers
EDFHG-03	KS-EDFHG-03-31
EDFHG-04	KS-EDFHG-04-31
EDFHG-06	KS-EDFHG-06-31