

■ Power Amplifiers For 10Ω - 10Ω Series Control Valves

These power amplifiers can drive two solenoid of 10Ω load simultaneously or separately, and the control can be done in the same way even though the object is separated by pressure system and flow rate system. Although the display of control unit on the front panel is **PRESS** and **FLOW**, they are exactly the same circuit, so there is no distinction between the two system when used.



■ Model Number Designation

AME	-D2	-1010	-11
Series Number	Type of Function	Coil Resistance of Valve	Design Number
AME	D2: DC Input Type	1010: 10 Ω × 2	11

■ Specifications

Description	Model No.	AME-D2-1010-11
Type of Function		DC Input Type
Max. Output Current		1 A (10Ω Solenoid)
Max. Input Voltage		+ 10 V DC
Input Impedance		10 kΩ
Max. Gain		1 A / 5 V
Dither		Variable 100-300 mA
Temperature Drift (Max.)		0.2 mA / °C
Power Supply		85 - 264 VAC
Power Input (Max.)		120 VA
Ambient Temperature		0-50°C (32-122°F)
External Setting Resistance		1 kΩ
Approx. Mass		4.3 kg (9.5 lbs.)

■ Applicable to Valve

Name of Valve	Model Numbers
Pilot Relief Valves	EDG-01 *
Relief Valves	EBG-03 EBG-06 EBG-10
Relieving and Reducing Valves	ERBG-06 ERBG-10
10 Ω Series Flow Control Valves	EFG-03/06 EFCG-03/06
10 Ω-10 Ω Series High Flow Series Flow Control and Relief Valves	EFBG-03 EFBG-06 EFBG-10

■ Applicable to Piston Pump

Name of Pump	Model Numbers
"A" Series Variable Displacement Piston Pump	A16- *-R-04 A22- *-R-04 A37- *-R-04 A56- *-R-04 A70- *R04 A90- *R04 A145- *R04
(Proportional Electro-Hydraulic Load Sensing Type)	Also, double pumps combined with the models listed above and fixed displacement vane pumps.

■ Instructions

Power supply for the setting adjuster up to two set can be provided from this power amplifier. However, please use the variable resistor or potentiometre of which impedance is 1 kΩ for the setting adjuster.

AME-D2-1010-11

[Example Diagram]

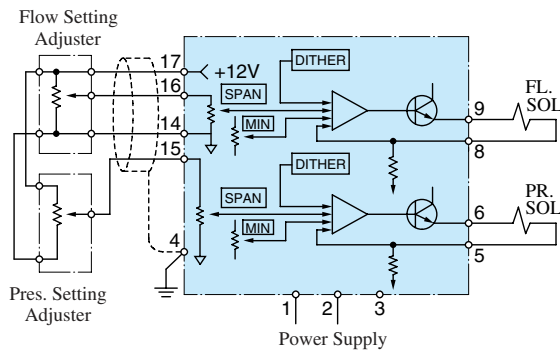

● Detail of Terminal Board

Terminal Number	Name
1	Power Supply 85 - 264 VAC
2	
3	
4	Ground G
5	Output to Pressure Control
6	Valve Solenoid PR. SOL
7	Ammeter
8	Output to Flow Control
9	Valve Solenoid FL. SOL
10	Ammeter
11	-12 V OUT -12 V
12	Common COM
13	+12 V OUT +12 V
14	Common COM
15	Input Signal for PRES. PR.IN
16	Input Signal for FLOW FL.IN
17	+12 V OUT +12 V

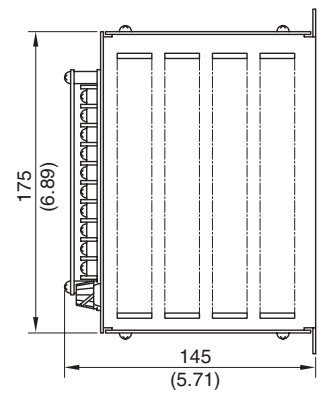
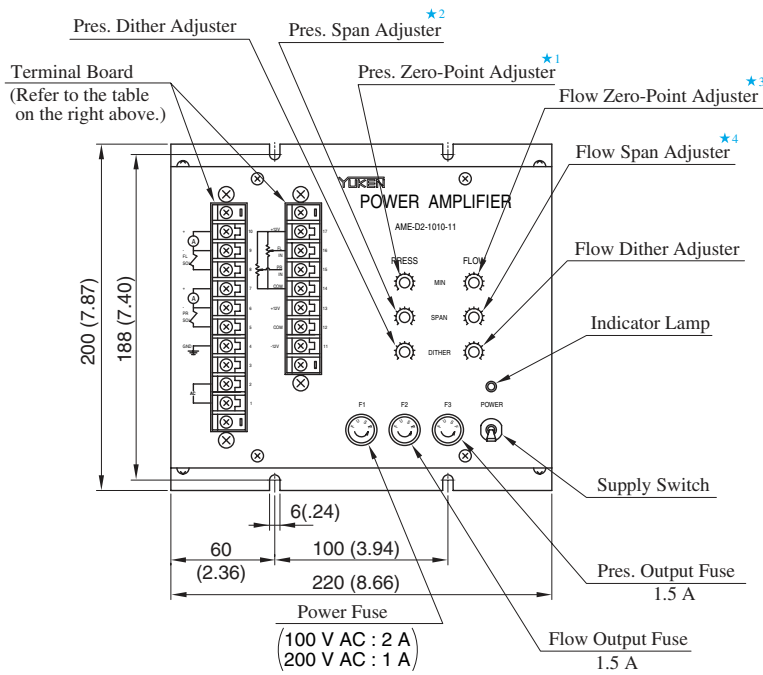

- ★1. Minimum Pressure Setting
- ★2. Variable Pressure Range Setting
- ★3. Minimum Flow Setting
- ★4. Variable Flow Range Setting

DIMENSIONS IN MILLIMETRES (INCHES)