

Direct Operated and High Response Type Proportional Electro-Hydraulic Directional and Flow Control Valves

These valves are closed-loop, high response type proportional electro-hydraulic directional and flow control valves with OBE (on board electronics). Two direct type models with a maximum rated flow rate up to 80 L/min (@ $\Delta P = 1$ MPa) are available. The addition of OBE to the well-received ELDFG series valves for simplified wiring offers simple operation and user-friendliness. With closed-loop control based on a combination of newly developed compact, powerful solenoids and a LVDT for spool position detection, the valves provide high response, high accuracy, and high reliability equivalent to those of simple servo valves.

2% Overlap spool type (spool type 3C2L) is suitable for position or pressure control.

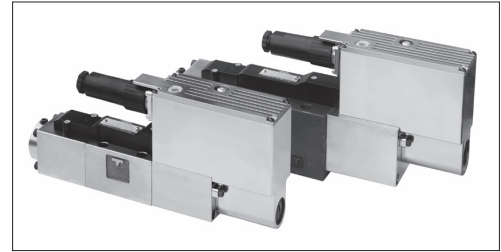

Graphic Symbols

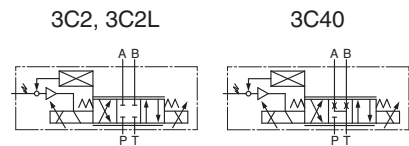

Specifications



Descriptions	Model Numbers	ELDFG-01EH			ELDFG-03EH	
		-10-3C*	-20-3C*	-35-3C*	-40-3C*	-80-3C*
Max. Operating Pressure	MPa	35			35	
Max. Tank Line Back Pressure	MPa	21				
Rated Flow [$\Delta P = 1$ MPa (4-Way Valve)]* ¹	L/min	10	20	35	40	80
Hysteresis		0.1% or less				
Repeatability		0.1% or less				
Step Response Pilot Pressure : 14 MPa (Typical Rating)* ²	(0→100%V)	16			23	
	(100→0%V)					
Frequency Response (±25% Amplitude) Pilot Pressure : 14 MPa (Typical Rating)* ³	Gain: -3 dB	80			50	
	Phase: -90°					
Vibration Proof	G	10				
Protection		IP65				
Ambient Temperature	°C	-15 - +60				
Spool Stroke to Stops	mm	±2.5			±3	
Coil Resistance [20 °C]	Ω	3			2	
Current Consumption	A	2 (Impulse Load 3)				
Approx. Mass	kg	3.3			7.3	
Electric Connection		6 + PE Connector				

★1. Use the valves so that the relationship between the valve pressure difference and the flow rate, as specified in “Range of Flow Control” on page H-63, is met.

★2. This value is measured for each valve; it may differ depending on the actual circuit.

★3. There are restrictions on the mounting position. See “Mounting Position” on page H-64.

Model Number Designation

ELDF	G	-01	EH	-10	-3C2	-XY	-C	-D	-10
Series Number	Type of Mounting	Valve Size	Amplifier Type	Rated Flow L/min	Spool Type*1	Direction of Flow	Fail-Safe Function	Input Signal/Spool Travel Monitoring	Design Number
ELDF : Direct Operated and High Response Type Proportional Electro-Hydraulic Directional and Flow Control Valves	G : Sub-Plate Mounting	01	EH : OBE Type	10 20 35	3C2 : 10% Overlap 	XY : Meter-In·Meter-Out	C : Neutral A : P-A, B-T Position B : P-B, A-T Position	D : Voltage Signal ±10 V (P→A→B→T Flow with Input Signal (+)) E : Current Signal 4 - 20 mA (P→A→B→T Flow with Current 12 - 20 mA Signal) F : Current Signal ±10 mA (P→A→B→T Flow with Input Signal (+))	10
		03		40 80	3C40 : A, B, T Connection  3C2L : 2% Overlap  (Linear Flow Gain)				

★1. The spool in the neutral position is shown.

★2. Phosphate ester type fluids are also supported. When phosphate ester type fluids are used, prefix "F-" to the model number because the special seals (fluororubber) are required to be used.

Accessories

Mounting Bolts

Model No.	Mounting Bolt	Qty.	Tightening Torque Nm
ELDFG-01EH	Socket Head Cap Screw: M5 × 45L	4	6 - 8
ELDFG-03EH	Socket Head Cap Screw: M6 × 35L	4	13 - 16

Note) The connector is separately available. Use a 6 + PE connector [EN175201 Part 804].

Instructions

Take care of filling the valve tank port with the hydraulic oil at any time. However, check valve with cracking pressure 0.04 MPa approx. shall be provided as required. The pipe from the tank port should be connected to the reservoir directly and the end of the pipe must always be in the oil.

Range of Flow Control

Control Method: 4-Way Valve

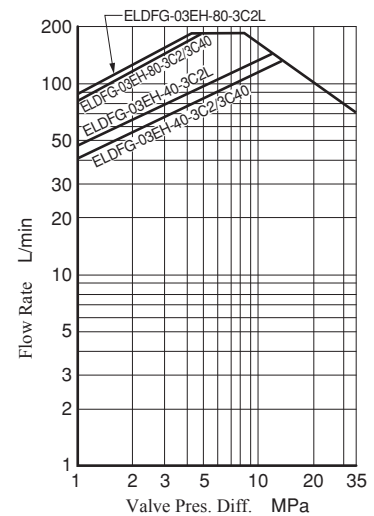
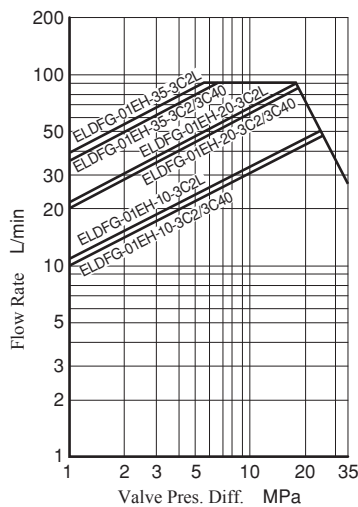
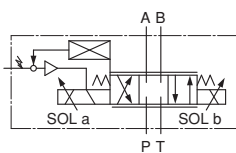

Control Method: 3-Way Valve

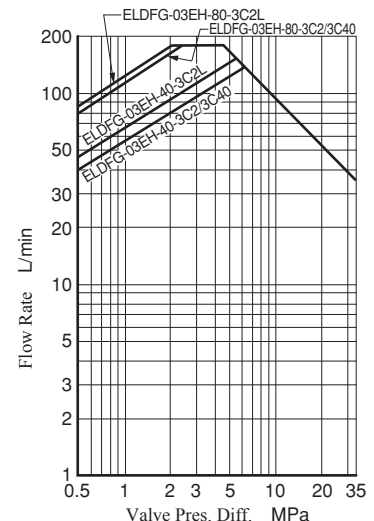
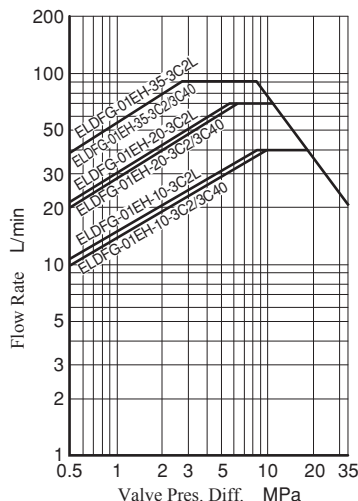
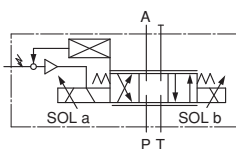

Sub-Plate

Model Number	Sub-Plate Model Numbers	Thread Size Rc	Mass	Page
ELDFG-01EH	DSGM-01-31	1/8	0.8	H-8
	DSGM-01X-31	1/4		
	DSGM-01Y-31	3/8		
ELDFG-03EH	DSGM-03-40	3/8	3	H-53
	DSGM-03X-40	1/2		
	DSGM-03Y-40	3/4		

★ Sub-plates are available. Specify the sub-plate model number from the table above. When sub-plates are not used, the mounting surface should have a good machined finish (▽).

Electrical Specification

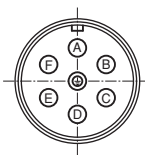

Valve Model		ELDFG- * EH- * -D	ELDFG- * EH- * -E	ELDFG- * EH- * -F
Pin A	Power Supply	24 V DC (21.6 - 26.4 V DC Included Ripple), 75 VA or more		
Pin B		0 V		
Pin C	Signal Common	COM (0 V)		
Pin D	Input (+) (Differential)*1	0 - ±10 V	4 - 20 mA	0 - ±10 mA
Pin E	Input (-) (Differential)*1	Ri ≥ 50 kΩ	Ri = 200 Ω	Ri = 200 Ω
Pin F	Spool Travel Monitoring	0 - ±10 V	4 - 20 mA	0 - ±10 mA
Pin	Protective Earth	—		

- ★1. Differential input signals can be used only for the valves with the voltage signal specifications of ±10 V (ELDFG- * EH- * -D).
- ★2. The recommended load resistance is 200 Ω.

I/O Signal Characteristics

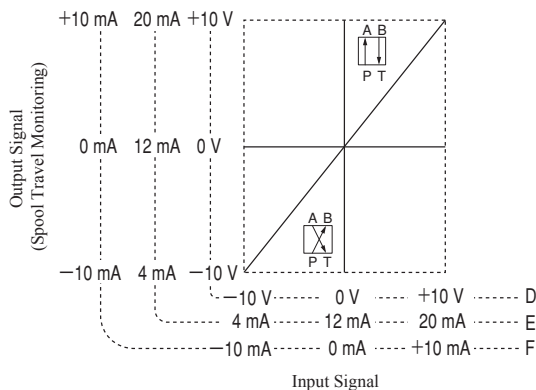

Circuit Schematic

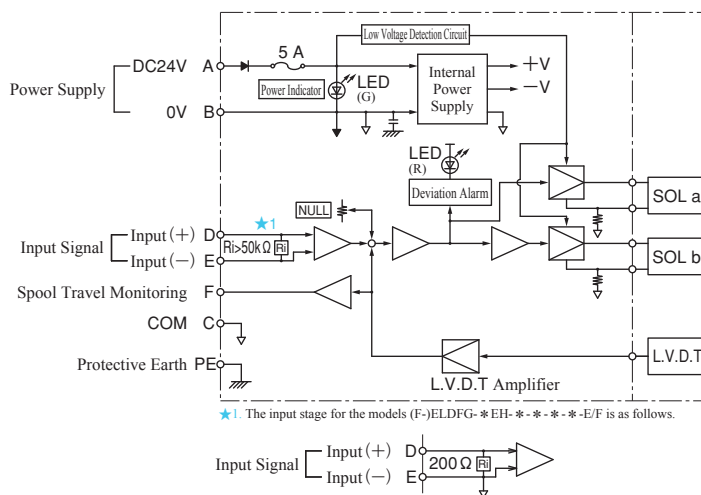

Details of the Valve Fail-Safe Functions

With reference to the information given table right, select the option for the fail-safe function according to the use of applications.

A separate safety circuit should be provided if the hydraulic actuator must be reliably held or stopped.

Condition: Electric System OFF

Model Numbers	Fail-Safe Function		
	Spool Position	Function	Graphic Symbol
ELDFG- * * EH- * -3C2-XY-C	Neutral	All Ports Blocked	
ELDFG- * * EH- * -3C2L-XY-C	Neutral	—	
ELDFG- * * EH- * -3C40-XY-C	Neutral	A, B, T Connection	
ELDFG-01EH- * - * -XY-A	about 20%	PABT Position	
ELDFG-03EH- * - * -XY-A	about 17%		
ELDFG-01EH- * - * -XY-B	about 20%	PBAT Position	
ELDFG-03EH- * - * -XY-B	about 17%		

★The fail-safe function's activation time depends on the electric and hydraulic conditions.

Mounting Position

Mount the valve with the angle of the axis line L-L' within about ±15° from the horizontal plane, as shown in the right figures. If the axial direction of the spool corresponds to the principal vibration direction, an external force may cause the spool to malfunction. The valve must be mounted in such a way that the axial direction of the spool does not correspond to the principal vibration direction.

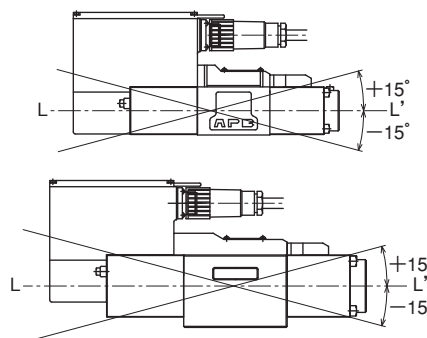

ELDFG-01EH-*-XY-***-10**

Mounting surface: ISO4401-AB-03-02-0-05

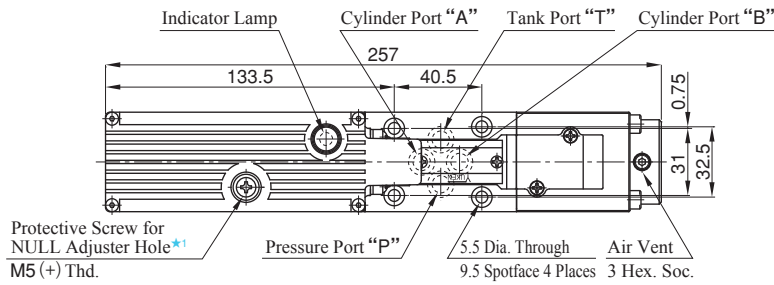

Color	Indicator Lamp
Green	Power Supply
Red	Deviation Alarm

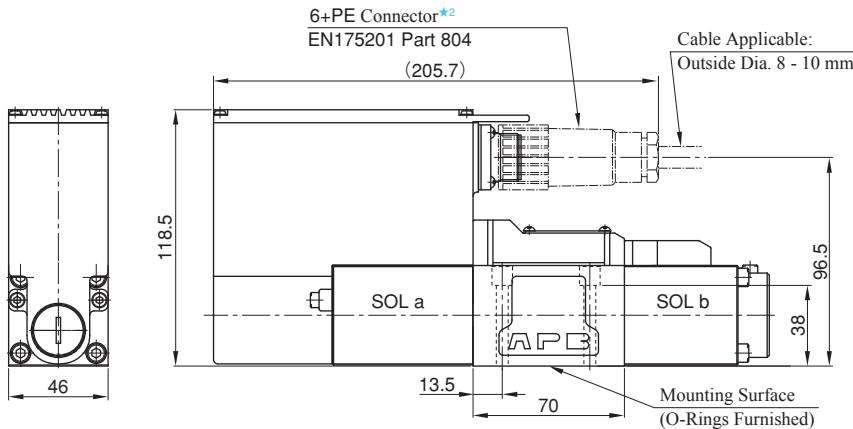

● O-Rings for the Ports
 AS568-012 (NBR-90): 4 Pieces

★1. For NULL adjustment, remove the protective screw and turn the trimmer behind the screw. After adjustment, be sure to attach the protective screw.

★2. The 6 + PE connector is not included with the valve. Prepare it separately.
 YUKEN parts number: TK290457-1

Note: For valve mounting surface dimensions, see the dimensional drawings of sub-plates (H-8) in common use.

ELDFG-03EH-*-XY-***-10**

Mounting surface: ISO4401-05-04-0-05

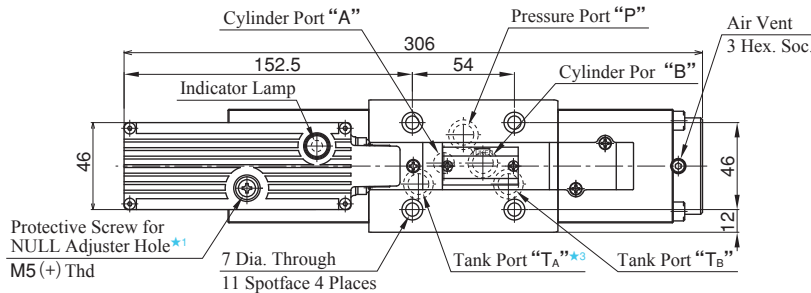

Color	Indicator Lamp
Green	Power Supply
Red	Deviation Alarm

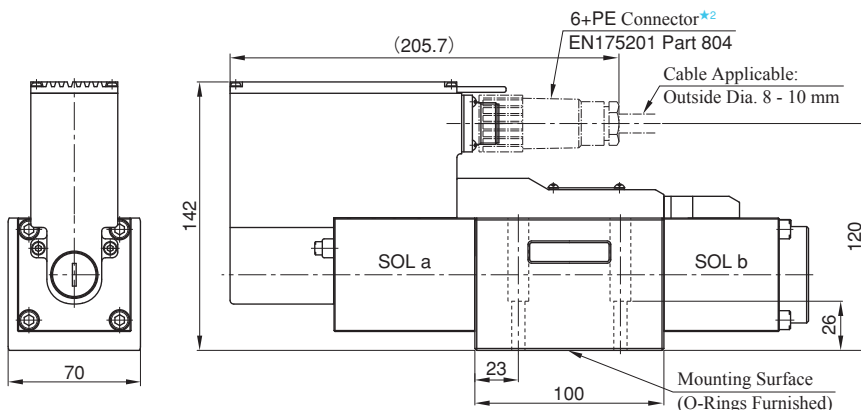

● O-Rings for the Ports
 AS568-014 (NBR-90): 5 Pieces

★1. For NULL adjustment, remove the protective screw and turn the trimmer behind the screw. After adjustment, be sure to attach the protective screw.

★2. The 6 + PE connector is not included with the valve. Prepare it separately.
 YUKEN parts number: TK290457-1

★3. With standard sub-plates, one ("TA") of the two tank ports is used, but either one may be used.

Note: For valve mounting surface dimensions, see the dimensional drawings of sub-plates (H-53) in common use.

No-Load Flow Characteristics

〈Conditions〉 ● Valve Pressure Difference: 1 MPa ● Viscosity: 30 mm²/s

ELDFG-01EH- *-3C2/3C40-XY- *- *-10

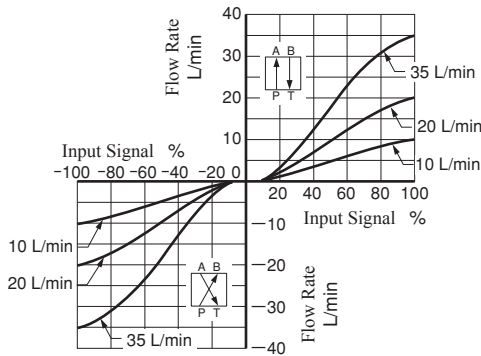

Around NULL Position
Input Signal -20 ⇔ +20 %

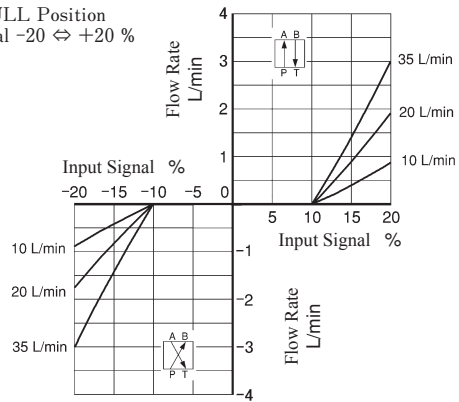

ELDFG-01EH- *-3C2L-XY- *- *-10

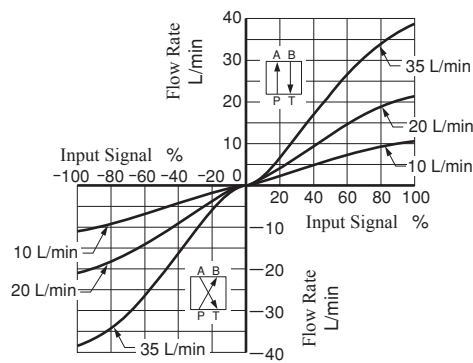

Around NULL Position
Input Signal -20 ⇔ +20 %

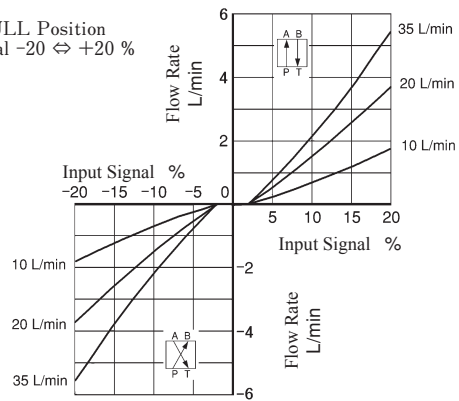

ELDFG-03EH- *-3C2/3C40-XY- *- *-10

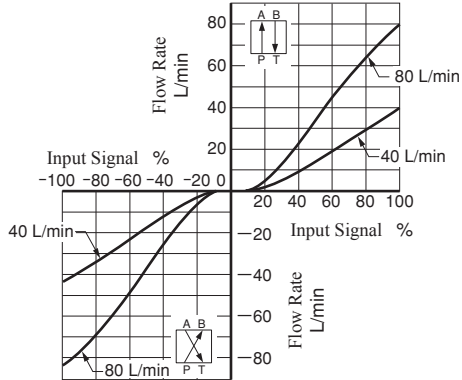

Around NULL Position
Input Signal -20 ⇔ +20 %

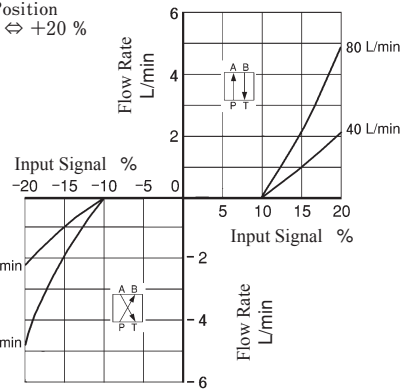

ELDFG-03EH- *-3C2L-XY- *- *-10

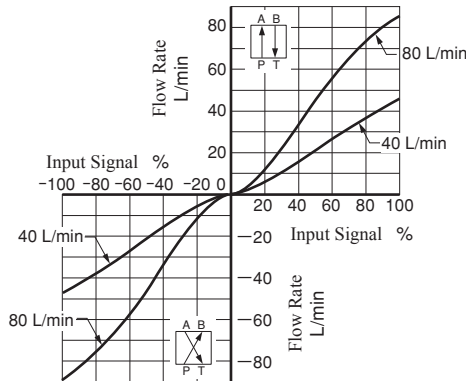

Around NULL Position
Input Signal -20 ⇔ +20 %

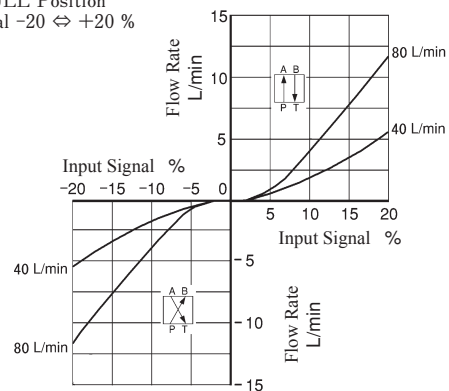

Step Response (Example)

〈Conditions〉 ● Hydraulic Circuit: Port A/B Closed ● Input Signal: 0 ↔ 100% ● Viscosity: 30 mm²/s

This value is measured for each valve; it may differ depending on the actual circuit.

● **ELDFG-01EH**

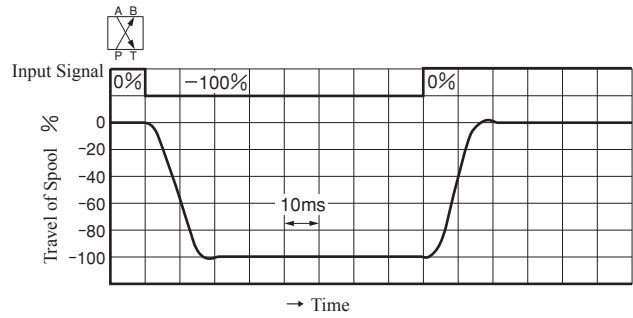
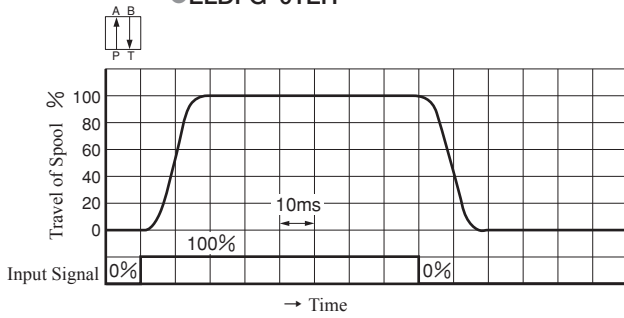

● **ELDFG-03EH**

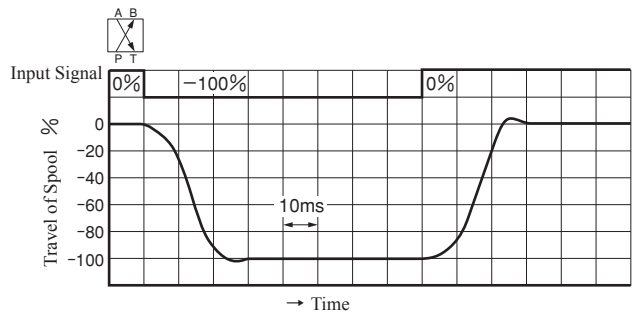
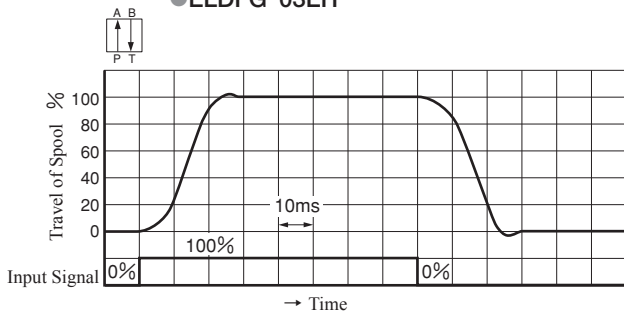

Frequency Response

〈Conditions〉 ● Hydraulic Circuit: Port A/B Closed ● Supply Pressure: 14 MPa ● Viscosity: 30 mm²/s

● **ELDFG-01EH**

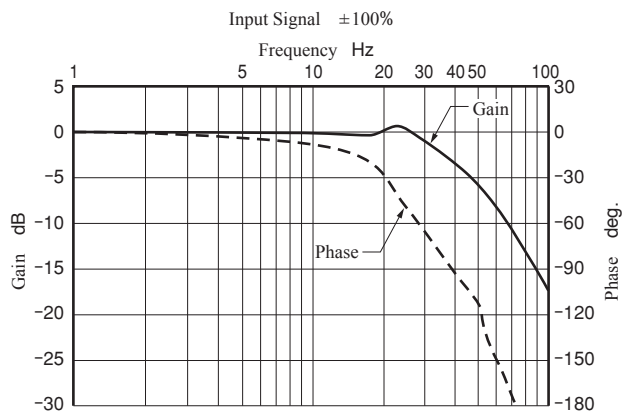
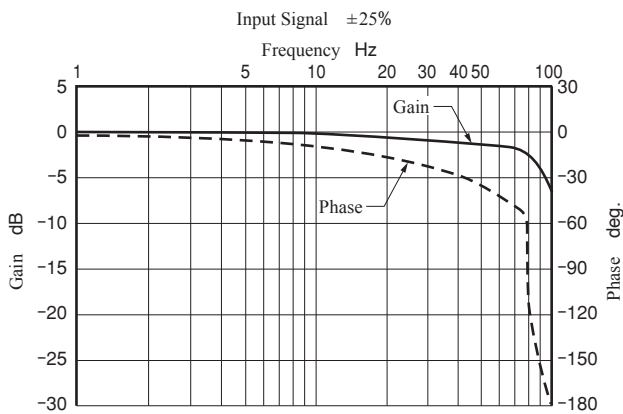

● **ELDFG-03EH**

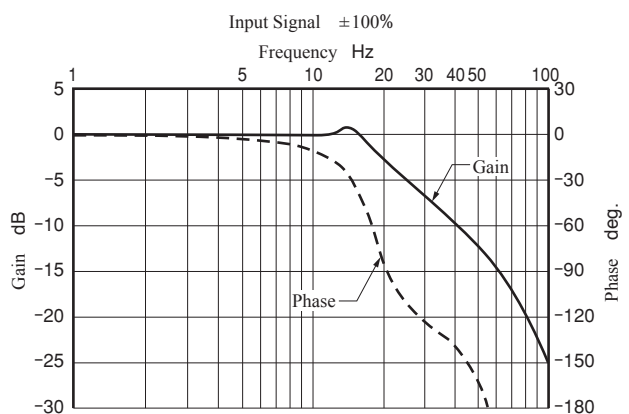
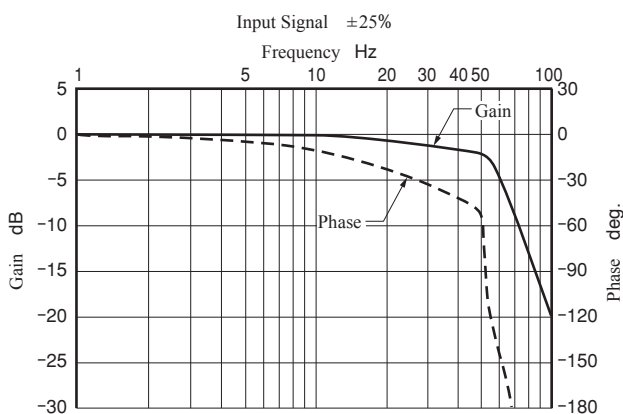

High Response Type Proportional Electro-Hydraulic Directional and Flow Control Valves (Two Stage Type)

These are high flow rate and two stage type valves as an addition to our highly appreciated product series: OBE type direct operated and high response proportional electro-hydraulic directional and flow control valve series.

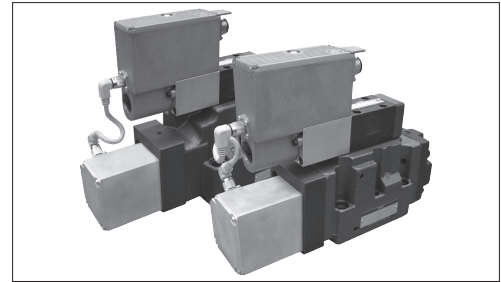

Graphic Symbols

● Spool Type “3C2”, “3C2P”, “3C2L”

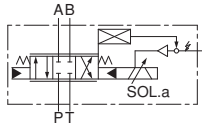

Internal Pilot
Internal Drain Type

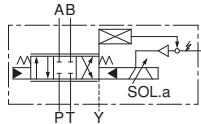

Internal Pilot
External Drain Type

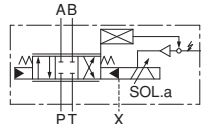

External Pilot
Internal Drain Type

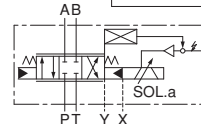

External Pilot
External Drain Type

● Spool Type “3C40”

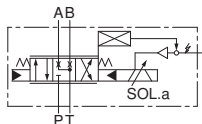

Internal Pilot
Internal Drain Type

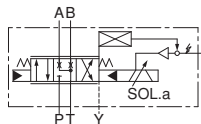

Internal Pilot
External Drain Type

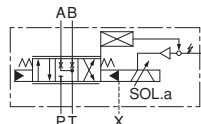

External Pilot
Internal Drain Type

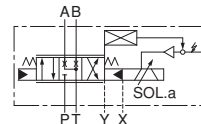

External Pilot
External Drain Type

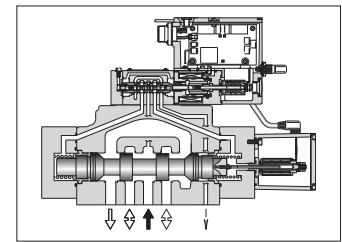

* “SOL.a” is for the model 04EH & 03EH.
For the model-06EH & 10EH, it is “SOL.b”

Specifications

Descriptions		Model Numbers	ELDFHG-03EH-100-3C2L	ELDFHG-03EH-100-*	ELDFHG-04EH	ELDFHG-06EH-350	ELDFHG-06EH-500	ELDFHG-10EH
Rated Flow [$\Delta P=1$ MPa (4-Way Valve)] $\Delta P = 0.5$ MPa per Land	L/min		90	100	280	350	500	1440
Max. Operating Pressure	MPa		31.5		35		31.5	35
Proof Pres. at Return Port* ¹	External Drain T Port	MPa	21		31.5	35	25	28
	External Drain Y Port	MPa	21					
	Internal Drain T & Y Ports	MPa	21					
Pilot Pressure* ²	MPa		1.5 to 25					
Pilot Flow Rate* ³	L/min		5 or more		11 or more	12 or more	16 or more	17 or more
Internal Leakage Supply Pressure: 14MPa Pilot Pressure: 14MPa Fluid Viscosity: 32mm ² /s	Pilot Valve	L/min	1.5 or less		1.8 or less			1.5 or less
	Main Valve L/min	3C2	3C2L:1.6 or less	3C40:1.0 or less 3C2P:5.6 or less	0.8 or less	0.9 or less	1.0 or less	5.0 or less
		3C40			1.6 or less	1.8 or less	1.8 or less	9.0 or less
		3C2P			6.8 or less	7.0 or less	8.0 or less	14.5 or less
3C2L	2.1 or less	2.5 or less			2.5 or less	11.5 or less		
Hysteresis			0.2% or less		0.1% or less			0.1% or less
Step Response (0 \leftrightarrow 100%) V Pilot Pressure: 14MPa (Typical Rating)* ⁴	ms		15	14	20	20	22	28
Frequency Response $\pm 25\%$ Amplitude Pilot Pressure: 14MPa (Typical Rating)* ⁴	Phase: -90°	Hz	50	55	51	50	45	33
	Gain: -3 dB	Hz	56	60	56			40
Vibration Proof* ⁵	m/s ²		100					
Protection			Equivalent to IP65					
Ambient Temperature	°C		-15 - +60					
Spool Stroke to Stops	mm		± 4	± 3.5	± 5	± 5	± 7	± 7
Spool End Area	cm ²		3		7	8	8	11.3
Current	A		2 (Impulse Loud 3)					
Coil Resistance at 20 °C	Ω		3					
Approx. Mass	kg		10.7	8.2	13	19		74.5
Electric Connection			6 + PE Connector [EN 175201 Part 804]					

★1. Pressure at the return port should be the actual supply pressure or less.

★2. Supply pressure for the pilot valve should be within the range described above and should also be 60% of the actual main valve supply pressure or more.

★3. Pilot flow is calculated with the above step response time at pilot pressure 14 MPa.

★4. This value is measured on a per-valve basis under the conditions described above; it may differ depending on the actual circuit and operating conditions.

★5. There are restrictions on the mounting position. See page H-71 for details.





Model Number Designation

ELDFHG	- 04	EH	- 280	-3C2P	- XY	-E	T	- C	-D	-10	
Series Number	Valve Size	Amplifier Type	Rated Flow L/min ΔP= 1 MPa (4-Way Valve)	Spool Type	Direction of Flow	Pilot Type	Drain Type	Fail-Safe Function	Input Signal/ Spool Travel Monitoring	Design Number	
ELDFHG: Two Stage Type High Response Type Proportional Electro-Hydraulic Directional and Flow Control Valves (Sub-Plate Mounting)	03	EH: OBE Type	100*2	3C2: 10% Overlap 3C40: A, B, T Connection	XY: Meter-In /Meter-Out	None: Internal Pilot E: External Pilot	None: External Drain T: Internal Drain	C: Neutral	D: Voltage Signal ± 10 V (PABT Flow with Positive Input) E: Current Signal 4 to 20 mA (PABT Flow with 12 to 20 mA Input) F: Current Signal ± 10 mA (PABT Flow with Positive Input)	10	
				3C2P: Zero Lap (Dual Flow Gain) 3C2L: 2% Overlap (Linear Flow Gain)				A: P→A,B→T Position (Valve Opening: 20%) B: P→B,A→T Position (Valve Opening: 20%)			
	04		280	3C2: 10% Overlap 3C40: A, B, T Connection				3C2P: Zero Lap (Dual Flow Gain) 3C2L: 2% Overlap (Linear Flow Gain)			A: P→A,B→T Position (Valve Opening: 10%) B: P→B,A→T Position (Valve Opening: 10%)
				3C2: 10% Overlap 3C40: A, B, T Connection				3C2P: Zero Lap (Dual Flow Gain) 3C2L: 2% Overlap (Linear Flow Gain)			C: Neutral
	06		350 500	3C2: 10% Overlap 3C40: A, B, T Connection				3C2P: Zero Lap (Dual Flow Gain) 3C2L: 2% Overlap (Linear Flow Gain)			A: P→A,B→T Position (Valve Opening: 10%) B: P→B,A→T Position (Valve Opening: 10%)
				3C2: 10% Overlap 3C40: A, B, T Connection				3C2P: Zero Lap (Dual Flow Gain) 3C2L: 2% Overlap (Linear Flow Gain)			C: Neutral
	10		1440	3C2: 10% Overlap 3C40: A, B, T Connection				3C2P: Zero Lap (Dual Flow Gain) 3C2L: 2% Overlap (Linear Flow Gain)			A: P→A,B→T Position (Valve Opening: 20%) B: P→B,A→T Position (Valve Opening: 20%)
				3C2: 10% Overlap 3C40: A, B, T Connection				3C2P: Zero Lap (Dual Flow Gain) 3C2L: 2% Overlap (Linear Flow Gain)			C: Neutral

- ★1. Phosphate ester type fluids are also supported. When phosphate ester type fluids are used, prefix "F-" to the model number because the special seals (fluororubber) are required to be used.
- ★2. In case of spool type "3C2L", it is 90L/min.

Details of the Valve Fail-Safe Functions

With reference to the information given below, select the option for the fail-safe function according to the use of applications. A separate safety circuit should be provided if the hydraulic actuator must be reliably held or stopped.

No.	Model Numbers	Fail-Safe Function	
		Spool Position	Function
1	ELDFHG-*EH-*3C2-XY-* *-C	Neutral	All Ports Blocked 
2	ELDFHG-*EH-*3C40-XY-* *-C	Neutral	A, B, T Connection 
3	ELDFHG-*EH-*3C2L/3C2P-XY-* *-A	Valve Opening: 10% (04EH, 06EH) Valve Opening: 20% (03EH, 10EH)	PABT Position 
4	ELDFHG-*EH-*3C2L/3C2P-XY-* *-B	Valve Opening: 10% (04EH, 06EH) Valve Opening: 20% (03EH, 10EH)	PBAT Position 

* The fail-safe function's activation time depends on the electric and hydraulic conditions.

Electrical specifications

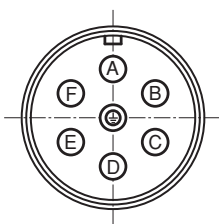

Input Signal		Voltage Signal "D"	Current Signal "E"	Current Signal "F"
Pin A	Power Supply	24 V DC (21.6 - 26.4 V DC Included Ripple), 75 VA or more		
Pin B		0 V		
Pin C	Signal Common	COM (0 V)		
Pin D	Input (+)(Differential)*2	0±10 V	4-20 mA	0±10 mA
Pin E	Input (-)(Differential)*2	Ri ≥ 50 kΩ	Ri = 200 Ω	Ri = 200 Ω
Pin F	Spool Travel Monitoring	0±10 V Ri ≥ 10 kΩ	4-20 mA Ri = 100-500 Ω*1	0±10 mA Ri = 100-500 Ω*1
Pin	Protective Earth	—		

- ★1. The recommended load resistance is 200 Ω.
- ★2. Differential input signals can be used only for the valves with the voltage signal specifications of ±10V. (ELDFHG- *EH- * -D)

I/O Signal Characteristics

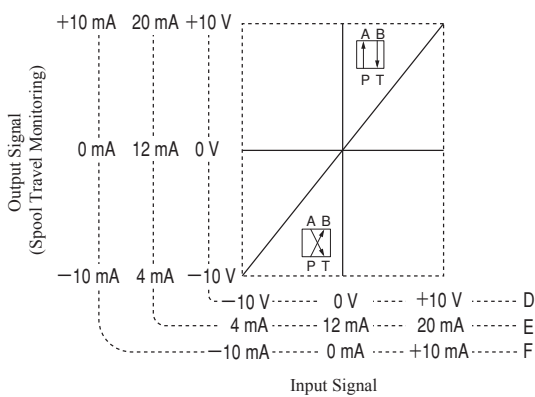

Block Diagram

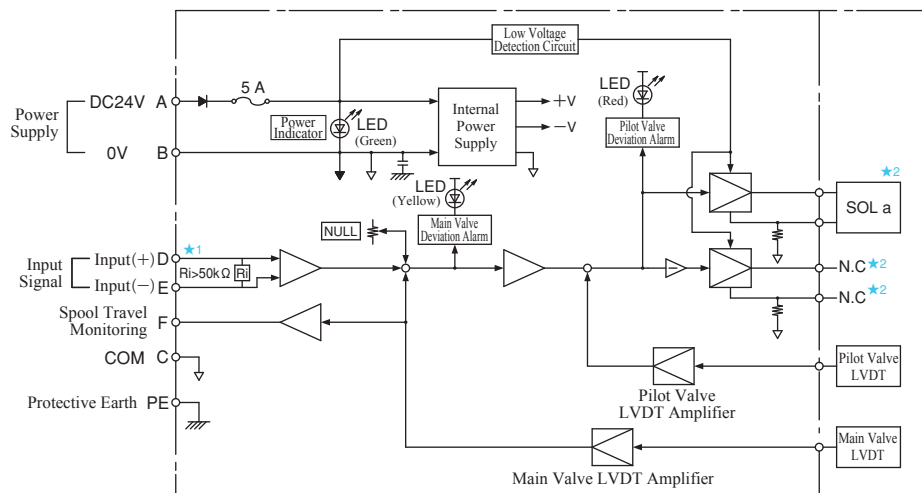

- ★1. The input stage for the current signal "E" and "F" is as follows.
- ★2. The solenoid name is for the model ELDFHG-03EH & 04EH. The name for the model ELDFHG-06EH & 10EH are as follows.

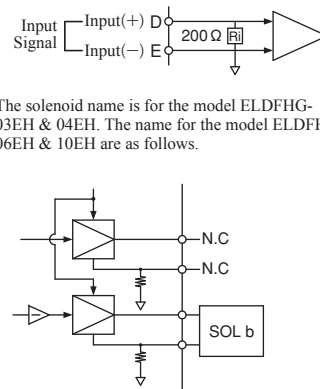

Accessories

Mounting Bolts

Valve Model Number	Mounting Bolt	Qty.	Tightening Torque Nm
ELDFHG-03EH	Hex. Socket Head Cap Screw: M6 × 35L	4	12.9 - 15.9
ELDFHG-04EH	Hex. Socket Head Cap Screw: M6 × 55L	2	
		Hex. Socket Head Cap Screw: M10×60L	4
ELDFHG-06EH	Hex. Socket Head Cap Screw: M12×85L	6	104 - 127
ELDFHG-10EH	Hex. Socket Head Cap Screw: M20×90L		493 - 603

Instructions

Take care of filling the valve tank port with the hydraulic oil at any time. However, check valve with cracking pressure 0.04 MPa approx. shall be provided as required. The pipe from the tank port should be connected to the reservoir directly and the end of the pipe must always be in the oil.

Mounting Position

Mount the valve with the angle of the axis line L-L' within about $\pm 15^\circ$ from the horizontal plane as shown in the right figure. When the principal vibration direction is consistent with the axial direction of the spool, the spool may malfunction due to external force. Make sure that the principal vibration direction is not consistent with the axial direction of the spool.

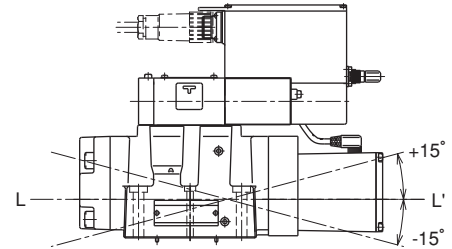

The Effective Range of The Fail-Safe Function

ELDFHG-03EH-100-3C2/3C40/3C2P/3C2L

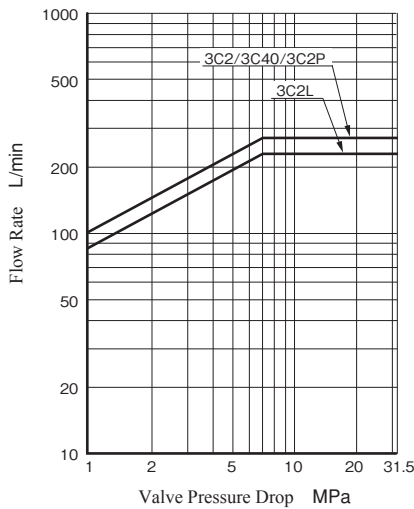

ELDFHG-04EH

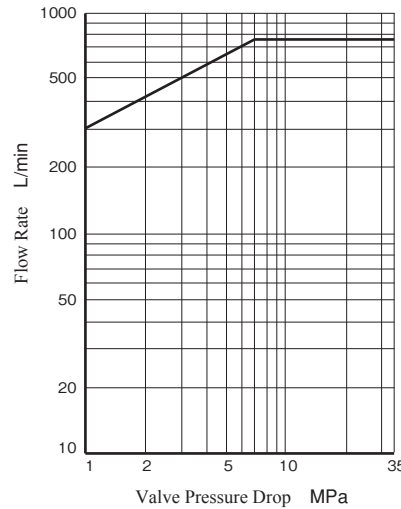

ELDFHG-06EH

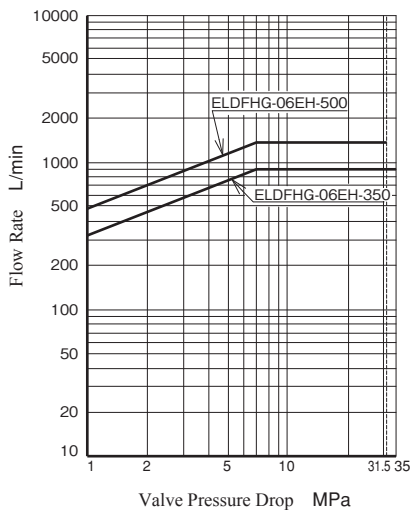

ELDFHG-10EH

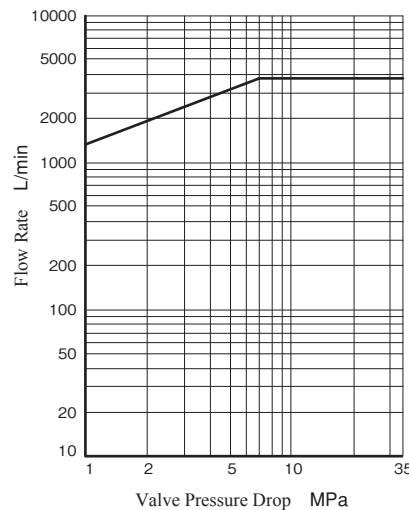

ELDFHG-03EH-100--XY-**-**-**10**

Mounting Surface: ISO 4401-05-05-05

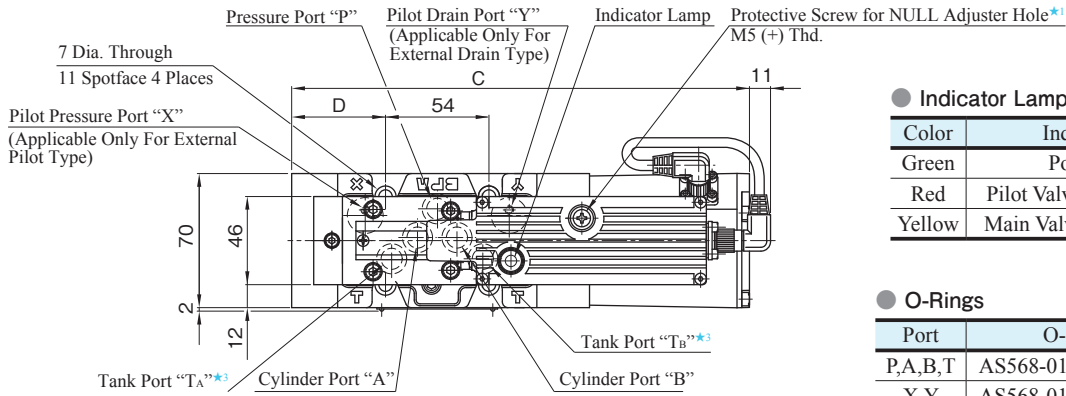

● **Indicator Lamp**

Color	Indicator Lamp
Green	Power Supply
Red	Pilot Valve Deviation Alarm
Yellow	Main Valve Deviation Alarm

● **O-Rings**

Port	O-Ring	Qty.
P,A,B,T	AS568-014 (NBR-90)	5
X,Y	AS568-016 (NBR-90)	2

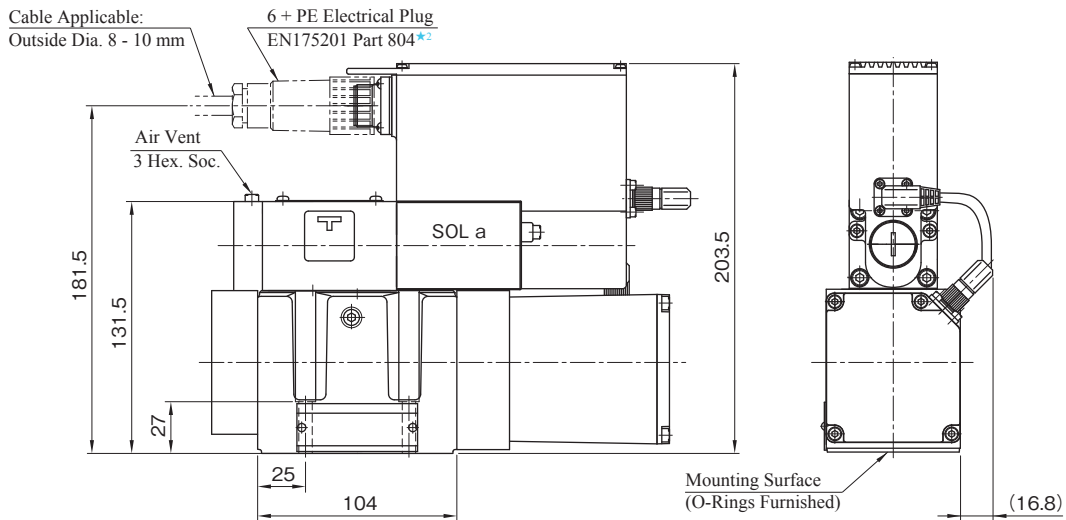

Model Numbers	C	D
ELDFHG-03EH-100-3C2/3C40/3C2P	239	49
ELDFHG-03EH-100-3C2L	248	58

● **Dimensions of Mounting Surface**

Prepare the mounting surface as shown below.

The mounting surface should have a good machined finish. ($\sqrt{}$)

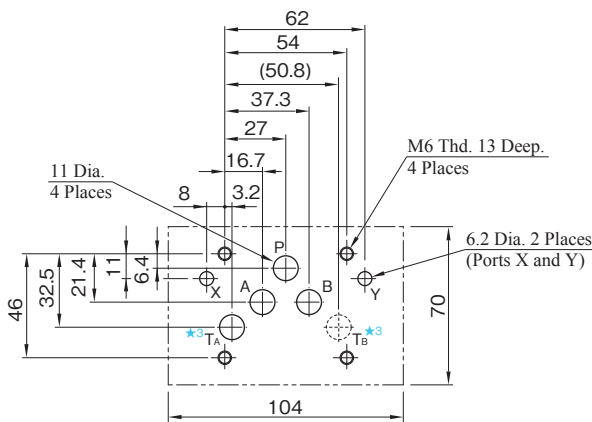

- ★1. For NULL adjustment, remove the protective screw and turn the trimmer behind the screw. After adjustment, be sure to attach the protective screw.
- ★2. The 6 + PE Electrical Plug is not included with the valve. Prepare it separately. YUKEN parts number: TK290457-1
- ★3. There are two tank ports "TA" and "TB"; however, "TA" may be used alone.

ELDFHG-04EH-280--XY-**-**-10**

Mounting Surface: ISO 4401-07-07-0-05

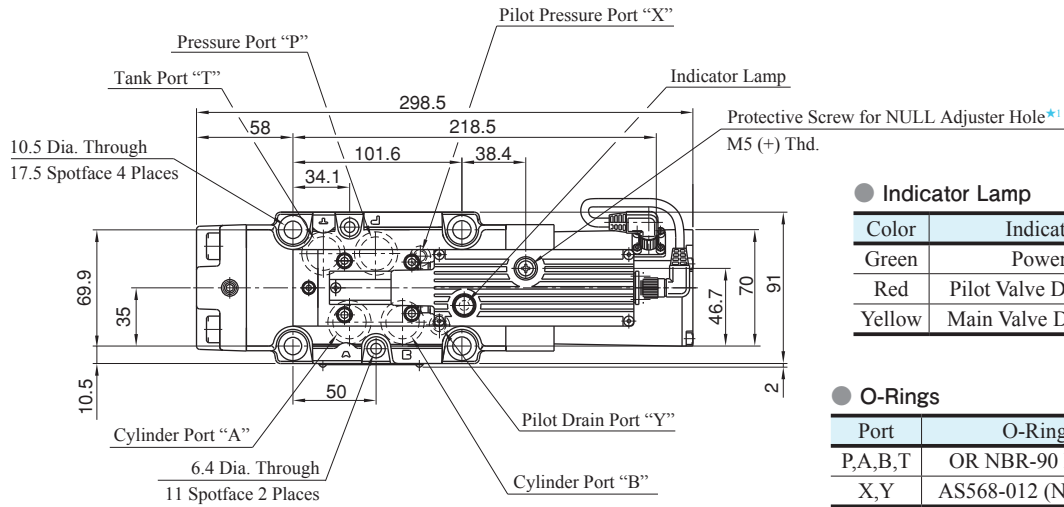

● **Indicator Lamp**

Color	Indicator Lamp
Green	Power Supply
Red	Pilot Valve Deviation Alarm
Yellow	Main Valve Deviation Alarm

● **O-Rings**

Port	O-Ring	Qty.
P,A,B,T	OR NBR-90 P22-N	4
X,Y	AS568-012 (NBR-90)	2

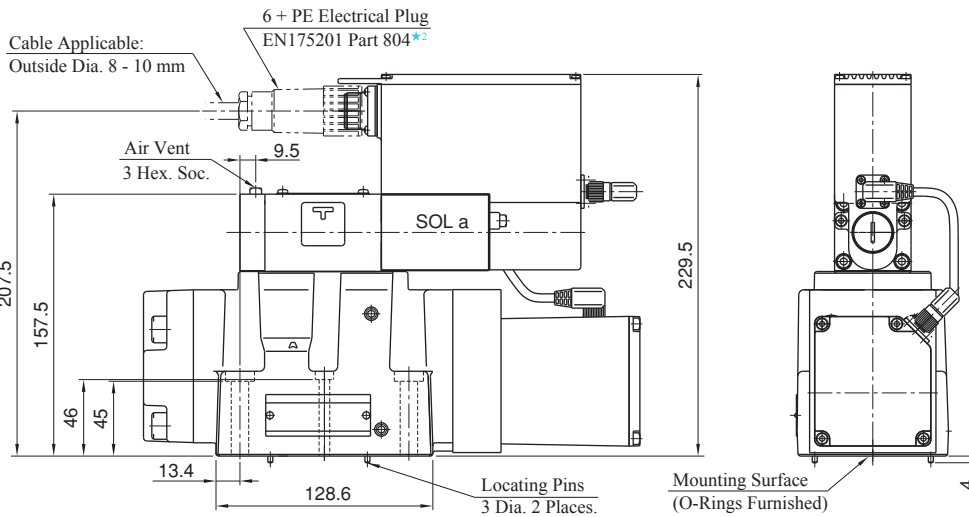

- ★1. For NULL adjustment, remove the protective screw and turn the trimmer behind the screw. After adjustment, be sure to attach the protective screw.
- ★2. The 6 + PE Electrical Plug is not included with the valve. Prepare it separately. YUKEN parts number: TK290457-1

● **Dimensions of Mounting Surface**

Prepare the mounting surface as shown below.

The mounting surface should have a good machined finish. ($\sqrt{6}$)

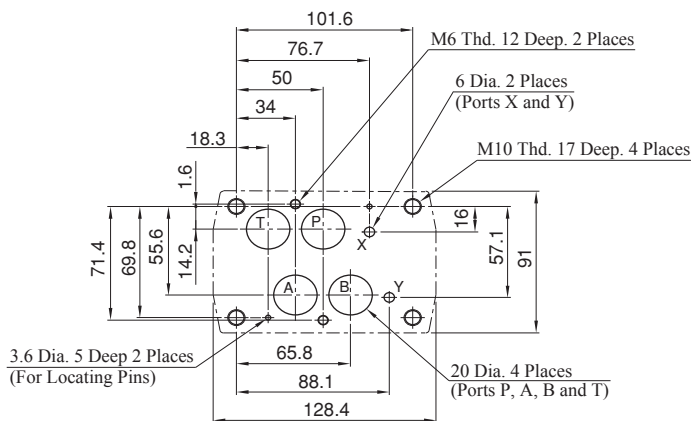

ELDFHG-06EH-350/500- *-XY- * * - * - * -10

Mounting Surface: ISO 4401-08-08-0-05

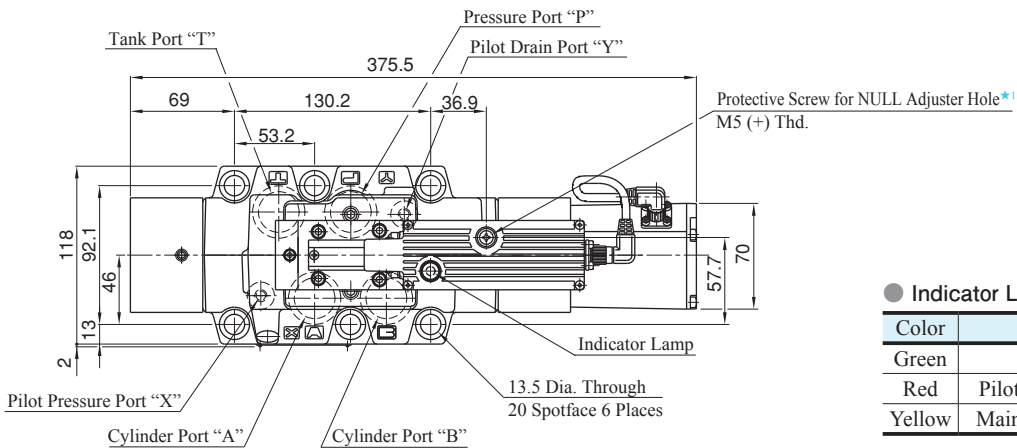

● **Indicator Lamp**

Color	Indicator Lamp
Green	Power Supply
Red	Pilot Valve Deviation Alarm
Yellow	Main Valve Deviation Alarm

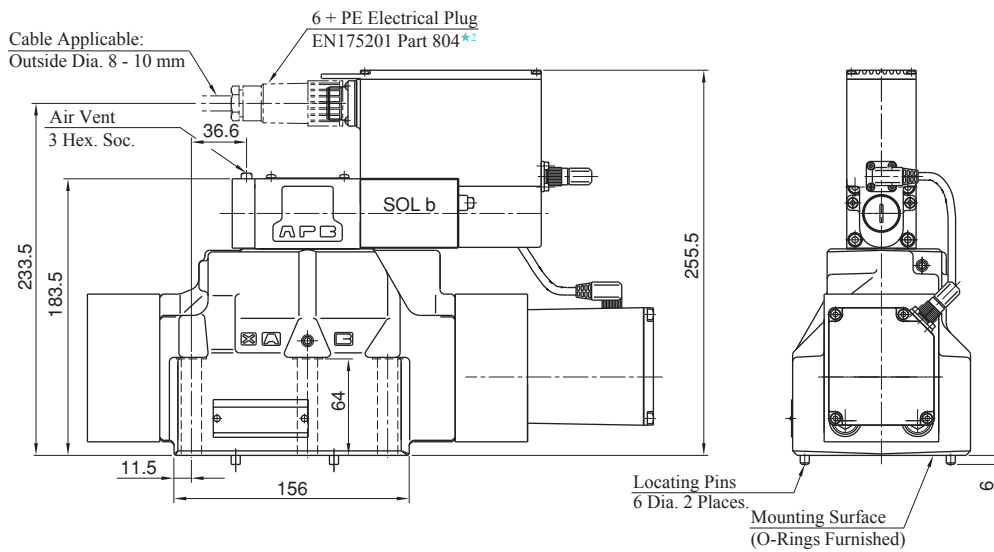

● **O-Rings**

Port	Model Numbers	O-Ring	Qty.
P,A,B,T	ELDFHG-06EH-350	AS568-123 (NBR-90)	4
	ELDFHG-06EH-500	AS568-126 (NBR-90)	4
X,Y	ELDFHG-06EH-350/500	OR NBR-90 P14-N	2

- ★1. For NULL adjustment, remove the protective screw and turn the trimmer behind the screw. After adjustment, be sure to attach the protective screw.
- ★2. The 6 + PE Electrical Plug is not included with the valve. Prepare it separately. YUKEN parts number: TK290457-1

● **Dimensions of Mounting Surface**

Prepare the mounting surface as shown in the right figure
The mounting surface should have a good machined finish. ($\sqrt{16}$)

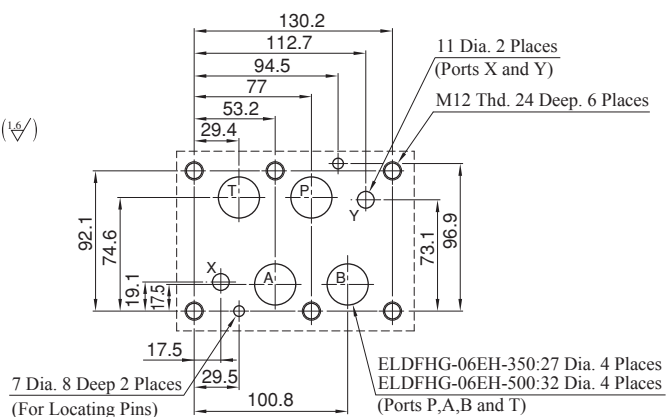

ELDFHG-10EH-1440- * -XY- * * - * - * -10

Mounting Surface: ISO 4401-10-09-0-05

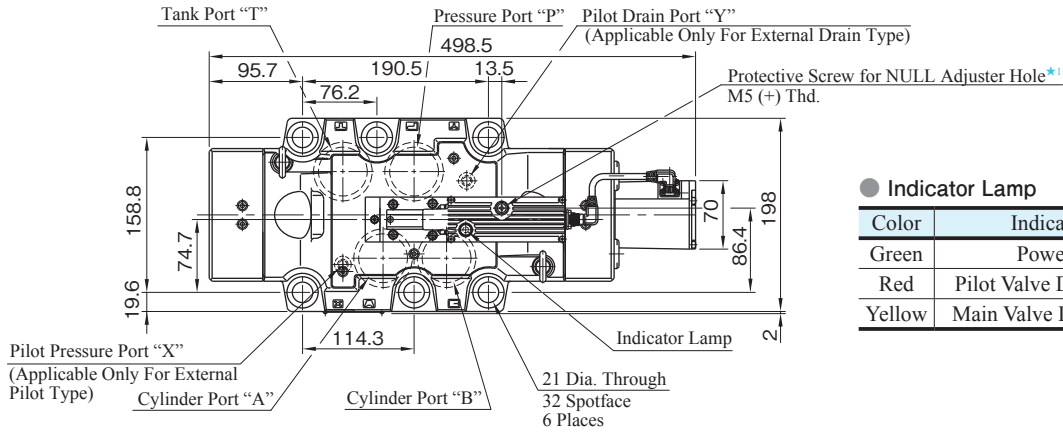

● **Indicator Lamp**

Color	Indicator Lamp
Green	Power Supply
Red	Pilot Valve Deviation Alarm
Yellow	Main Valve Deviation Alarm

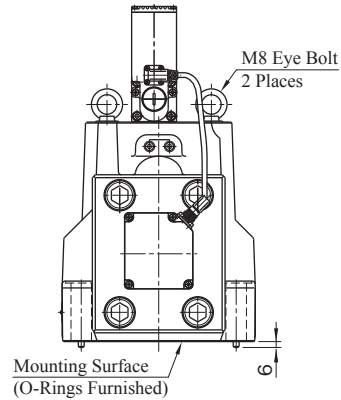
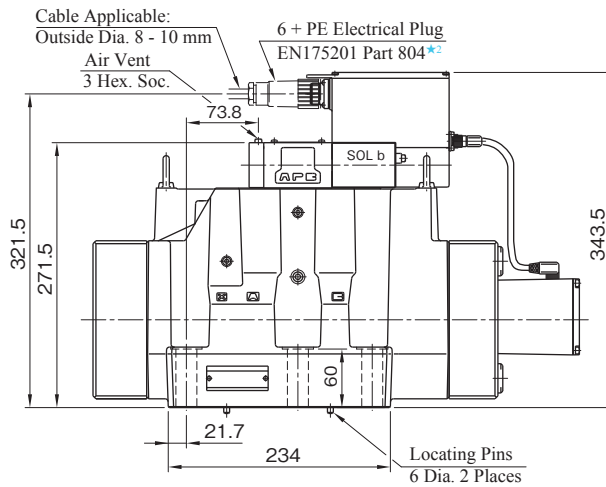

● **O-Rings**

Port	O-Ring	Qty.
P,A,B,T	AS568-227 (NBR-90)	4
X,Y	AS568-015 (NBR-90)	2

★1. For NULL adjustment, remove the protective screw and turn the trimmer behind the screw. After adjustment, be sure to attach the protective screw.

★2. The 6 + PE Electrical Plug is not included with the valve. Prepare it separately. YUKEN parts number: TK290457-1

● **Dimensions of Mounting Surface**

Prepare the mounting surface as shown in the below figure

The mounting surface should have a good machined finish. ($\frac{1}{\psi}$)

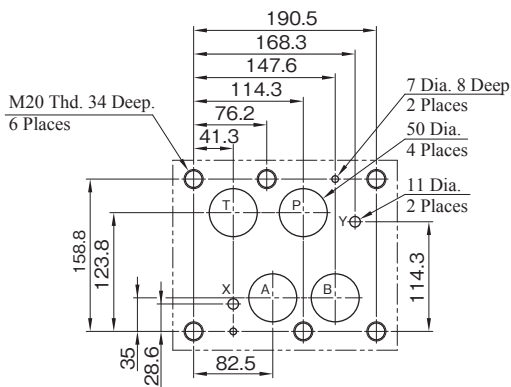

No-Load Flow Characteristics

(Conditions) ● Valve Pressure Difference: 1 MPa (4-Way Valve/Pressure Difference per Land: 0.5 MPa)
 ● Viscosity: 30 mm²/s

ELDFHG-03EH-100-3C2L

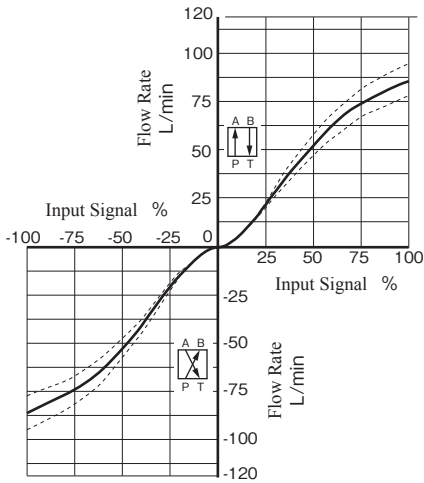

ELDFHG-03EH-100-3C2/3C40/3C2P

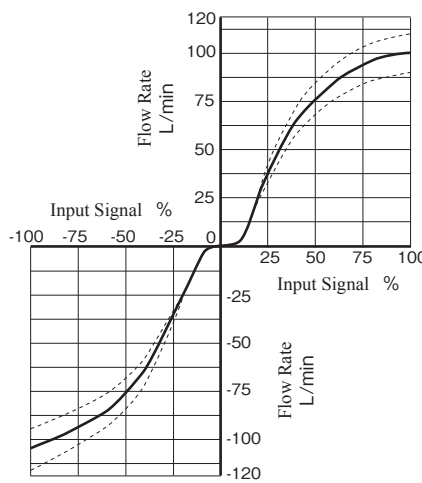

**Around Null Position
Input Signal -20↔+20%**

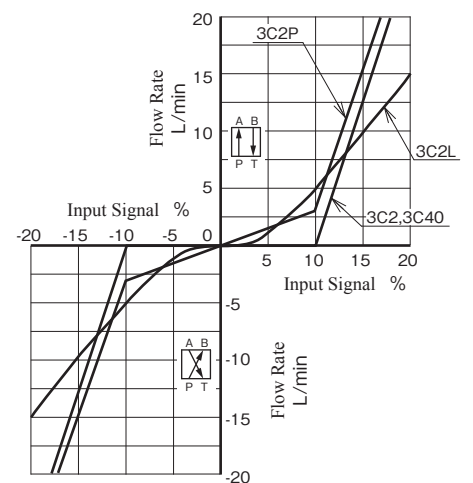

ELDFHG-04EH-280-3C2L

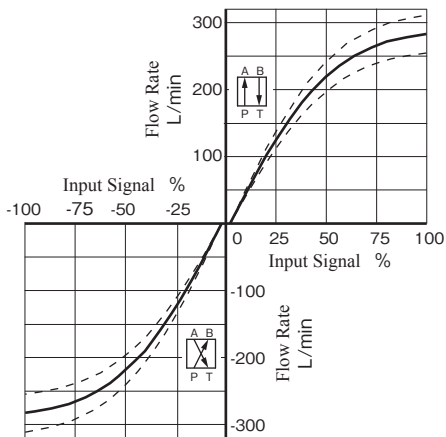

ELDFHG-04EH-280-3C2/3C40/3C2P

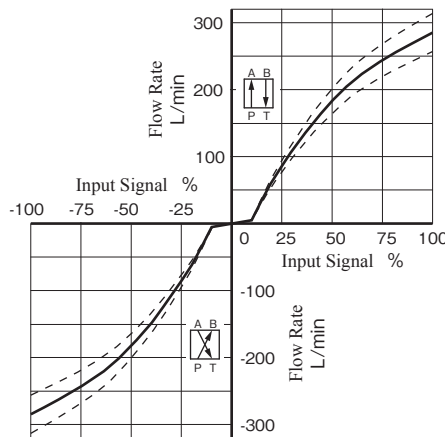

**Around Null Position
Input Signal -20↔+20%**

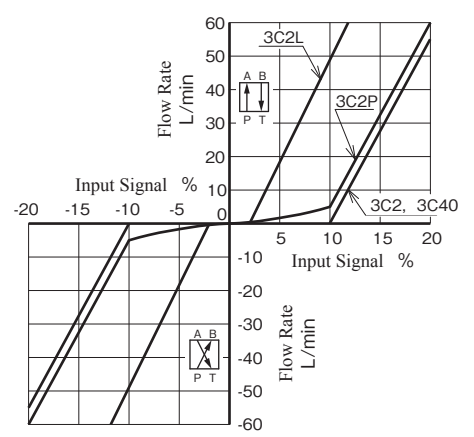

ELDFHG-06EH-350-3C2L

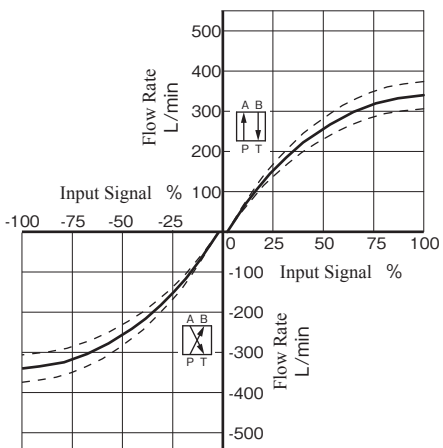

ELDFHG-06EH-350-3C2/3C40/3C2P

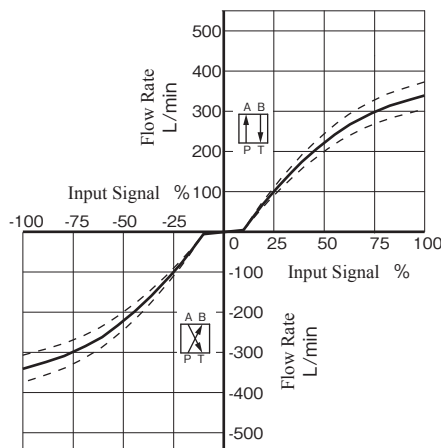

**Around Null Position
Input Signal -20↔+20%**

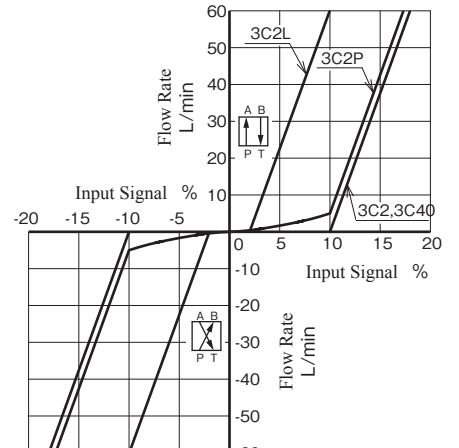

ELDFHG-06EH-500-3C2L

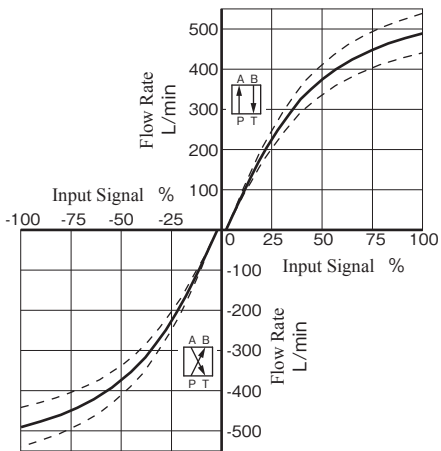

ELDFHG-06EH-500-3C2/3C40/3C2P

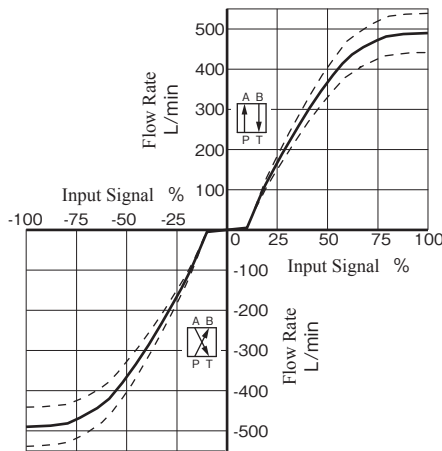

**Around Null Position
Input Signal -20↔+20%**

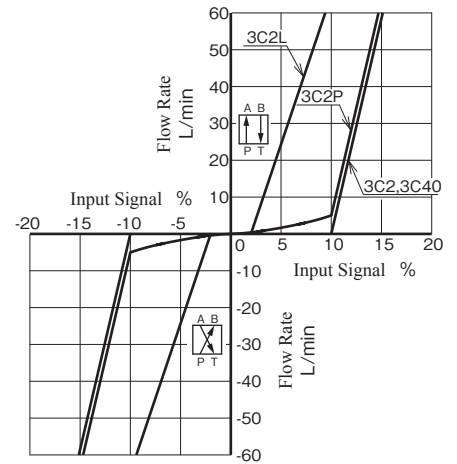

ELDFHG-10EH-1440-3C2L

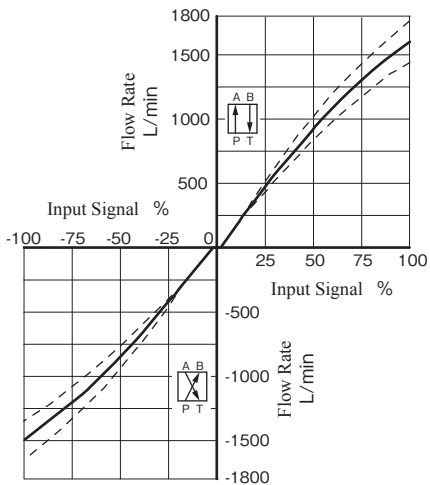

ELDFHG-10EH-1440-3C2/3C40/3C2P

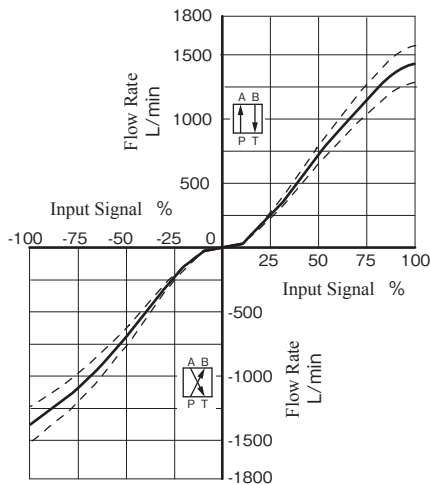

**Around Null Position
Input Signal -20↔+20%**

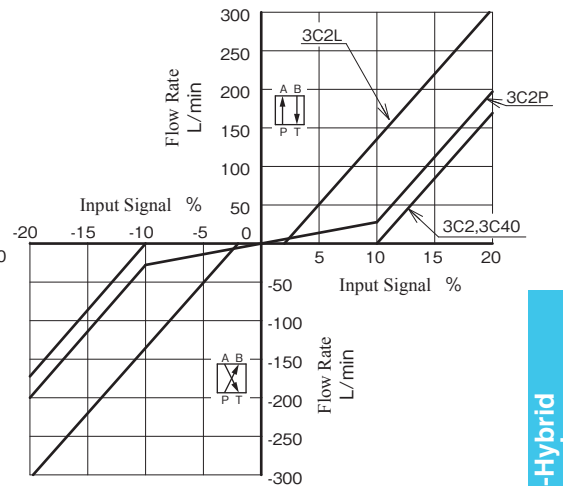

Step Response (Example)

- Hydraulic Circuit: Port A/B Closed
- Supply Pressure and Pilot Pressure: 14 MPa
- Input Signal: 0⇔100%
- Viscosity: 30 mm²/s

This value is measured on a per valve basis; the actual step response may differ depending on the actual circuit.

ELDFHG-03EH-100-3C2/3C40/3C2P

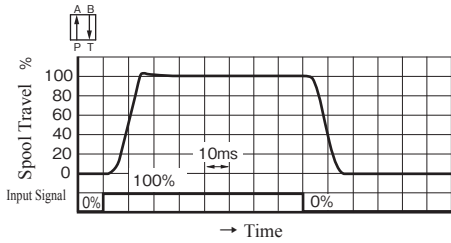

ELDFHG-03EH-100-3C2L

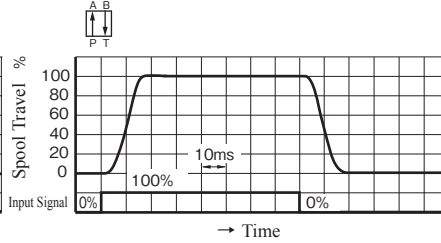

ELDFHG-04EH

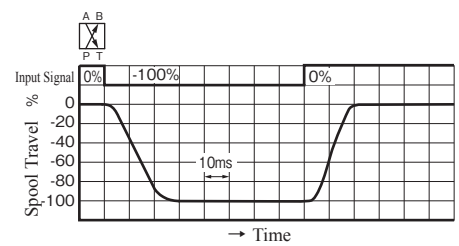
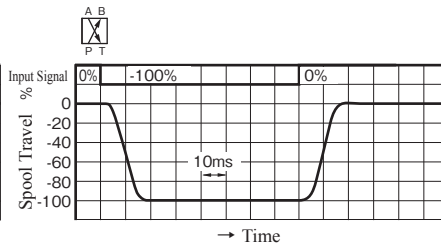
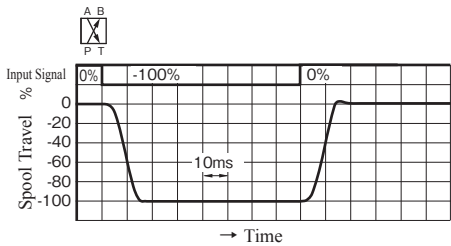
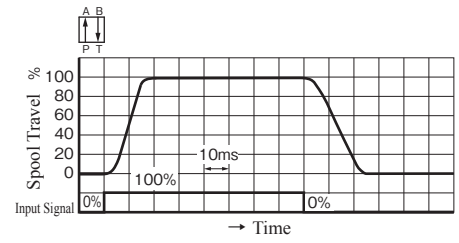

ELDFHG-06EH-350

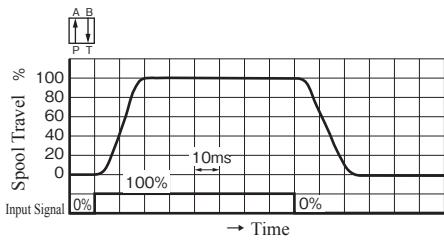

ELDFHG-06EH-500

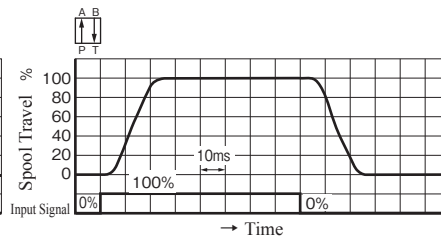

ELDFHG-10EH

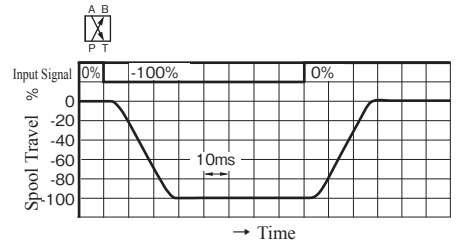
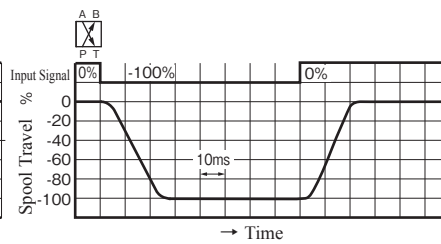
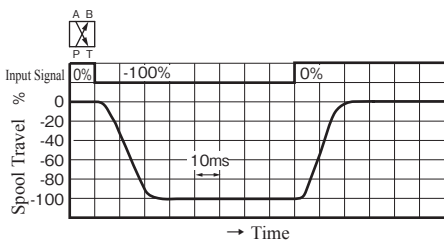
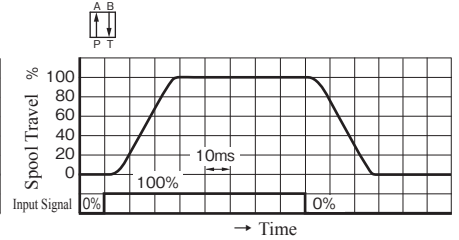

Frequency Response (Example)

〈Conditions〉 ● Hydraulic Circuit: Port A/B Closed ● Supply Pressure and Pilot Pressure: 14 MPa
 ● Viscosity: 30 mm²/s

This value is measured on a per valve basis; the actual frequency response may differ depending on the actual circuit.

ELDFHG-03EH-100-3C2/3C40/3C2P

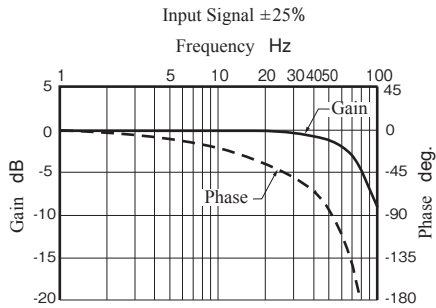

ELDFHG-03EH-100-3C2L

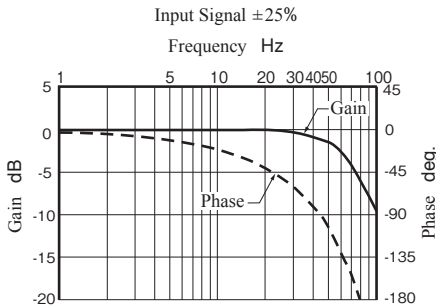

ELDFHG-04EH

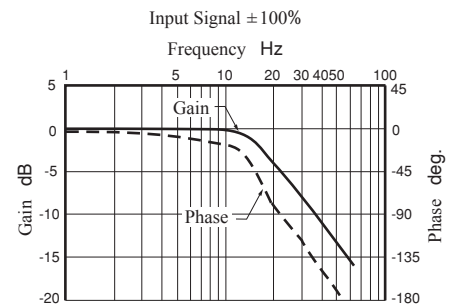
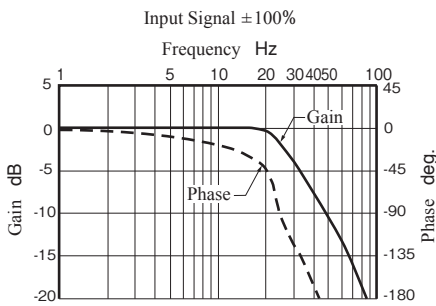
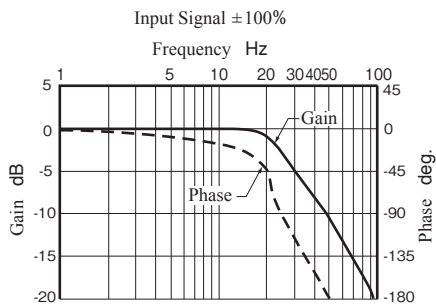
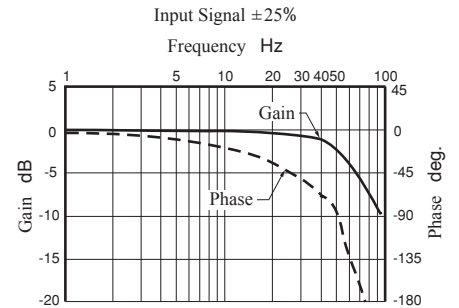

ELDFHG-06EH-350

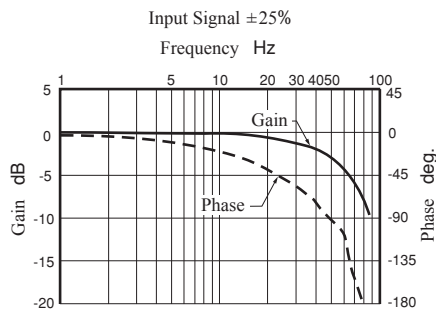

ELDFHG-06EH-500

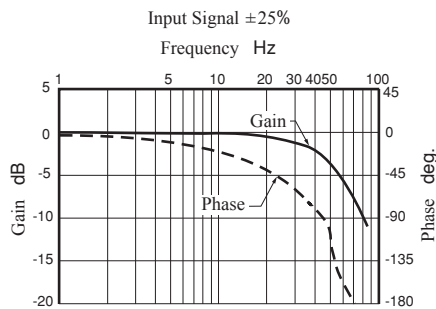

ELDFHG-10EH

