

# Series TAP 50

Nylon oil filler and air breather filler caps

## Dimensions

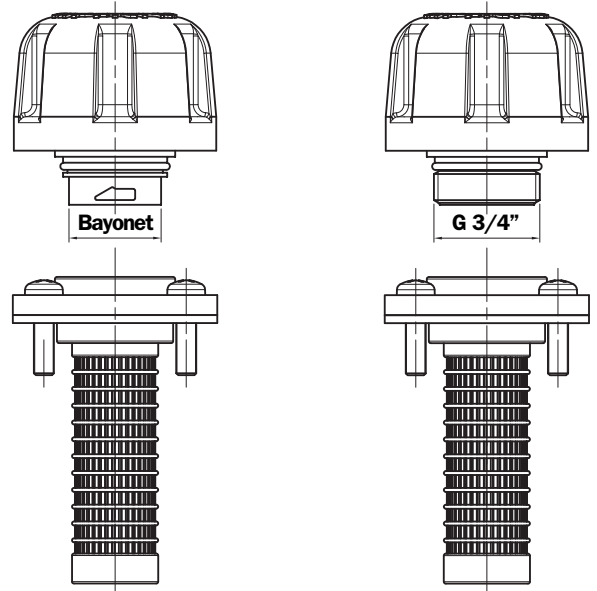
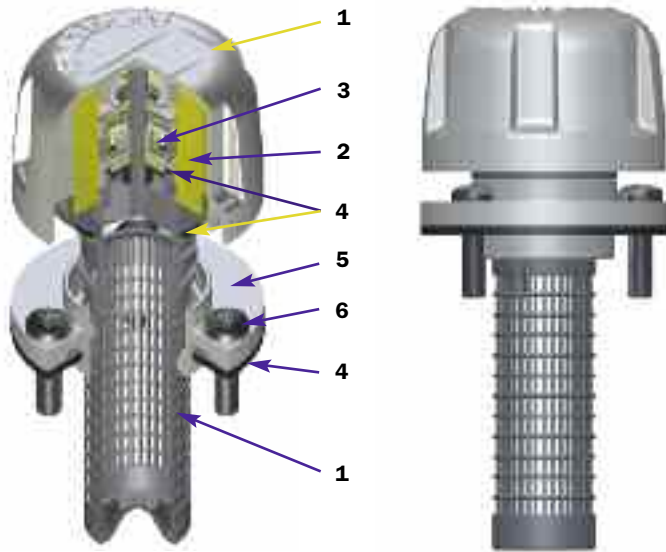

### TAP50 (Materials)

- 1 - Cover/ringnut: Nylon
- 2 - Filter element: Impregnated paper  
Polyurethane
- 3 - Pressurisation valve: Nylon  
Galvanised Steel  
NBR
- 4 - Seal: NBR
- 5 - Flange: Nylon
- 6 - Screws: Galvanised Steel
- 7 - Basket: Nylon

### Flow rates with $\Delta p$ : 0,02 bar

Filtration	l/min
10 $\mu$ m	202

### Quantity per pack Number of Parts

TAP50	10
-------	----

### Weight

TAP50: 0,060 kg

### Reservoir holes

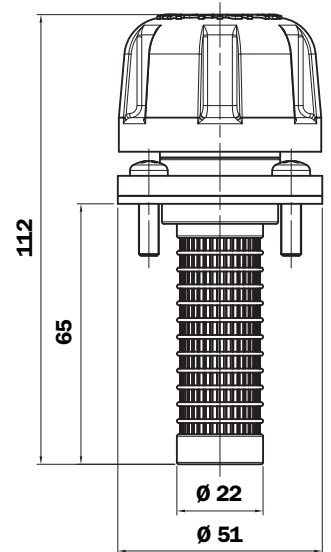
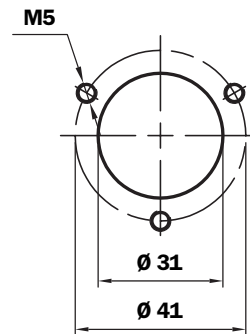

## Ordering information

### Filler cap

#### TAP50

Example: TAP50 **B** **10** **A** **0** **1** **P01**

### 1 - Connection to reservoir

- B** Flange with bayonet connection
- C** Flange with bayonet connection G 3/4"

### 2 - Filter element

- 03** 3  $\mu$ m - Impregnated paper
- 10** 10  $\mu$ m - Polyurethane

### 3 - Seal

- A** NBR

### 4 - Valves

- 0** Without
- 1** 0,5 bar pressurisation valve

### 5 - Basket

- 1** L= 65 mm

### 6 - Options

- P01** MP Filtri standard

# Series TAP 90

## Nylon oil filler and air breather filler caps

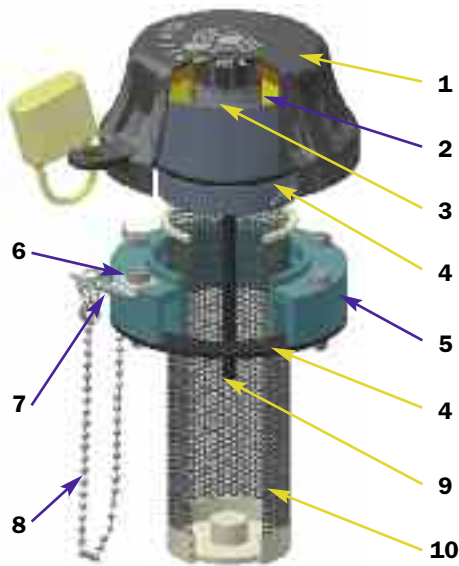

### TAP90 (Materials)

- 1 - Cover/ringnut: Nylon
- 2 - Filter element: Impregnated paper  
Polyurethane
- 3 - Pressurisation valve: Nylon  
Galvanised Steel  
NBR
- 4 - Seal: NBR
- 5 - Flange B: Nylon
- 6 - Screws: Galvanised Steel
- 7 - Padlock tab: Galvanised Steel
- 8 - Chain, ring: Brass
- 9 - Dipstick: Phosphated Steel
- 10 - Basket: Galvanised Steel/Nylon

### Flow rate with $\Delta p$ : 0,02 bar

Filtration	l/min
3 $\mu m$	450
10 $\mu m$	550

### Weight

Basket L 120 mm:	0,250 Kg
Basket L 250 mm:	0,310 Kg

**TAP90 B.....**  
Flange with  
bayonet connection



External chain

**TAP90 R.....**  
Flange with  
M52x2 connection



Internal chain

**TAP90 F.....**  
Flange with spigot  
DIN 24557 Connection  
M52x2



Internal chain

**TAP90 C.....**  
Weld riser  
Connection M52x2



Weld riser in  
Galvanised Steel,  
internal chain

**TAP90 B-C-R-F**  
With dipstick



**TAP90 B-C-R-F**  
Closed filler cap without  
filter element



**TAP90 B-C-R-F**  
Filler cap with filter  
element



**TAP90 B-C-R-F**  
Filler cap with  
pressurisation valve



# Dimensions

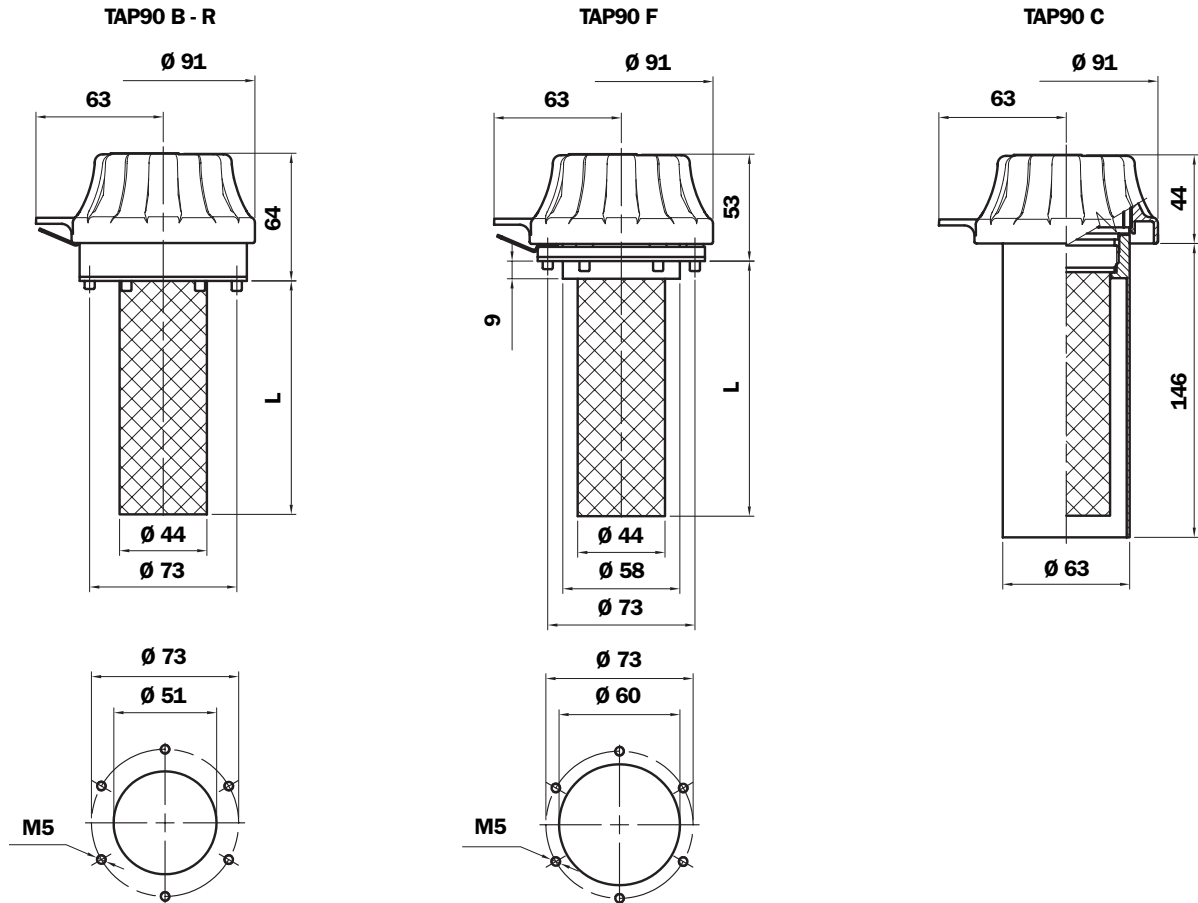

## Ordering information

**Filler cap**  
**TAP90**  
**Example: TAP90**

1	2	3	4	5	6	7
<input type="checkbox"/>	<input type="checkbox"/>	<input type="checkbox"/>	<input type="checkbox"/>	<input type="checkbox"/>	<input type="checkbox"/>	<input type="checkbox"/>
<b>B</b>	<b>03</b>	<b>A</b>	<b>1</b>	<b>0</b>	<b>5</b>	<b>P01</b>

### 1 - Connection to reservoir

- B** Flange with bayonet connection
- C** Weld riser (M52X2 version only)
- F** Flange with threaded M52x2 connection Spigot Ø 60 (DIN 24557)
- R** Flange with M52X2 threaded connection

### 2 - Filter element

- 00** Without filter (Blank filler cap)
- 03** 3 µm - Impregnated paper
- 10** 10 µm - Polyurethane

### 3 - Seal

- A** NBR

### 4 - Valves

- 0** Without
- 1** 0.3 bar pressurisation valve
- 2** 0.7 bar pressurisation valve

### 5 - Variantes

- 0** Standard
- L** With Padlock tab
- A** With Dipstick
- C** With Chain external for connection **B**  
With Chain internal for connection **C-F-R** (with basket only)
- D** With Padlock tab and chain external for connection **B**  
With Padlock tab and chain internal for connection **C-F-R** (with basket only)
- E** Dipstick and chain external (only connection **B**)
- F** Dipstick and Padlock tab
- G** Dipstick, Padlock tab and chain external (only connection **B**)

### 6 - Basket (Stainless steel basket on request)

- 0** Without
- 1** L= 120 mm
- 3** L= 250 mm

In the version with chain the L= 120 basket features a press fitting.

### 7 - Options

- P01** MP Filtri standard

# Series TAP 114

Nylon oil filler and air breather filler caps



**Example  
TAP114  
Length 1**



**Example  
TAP114  
Length 2**

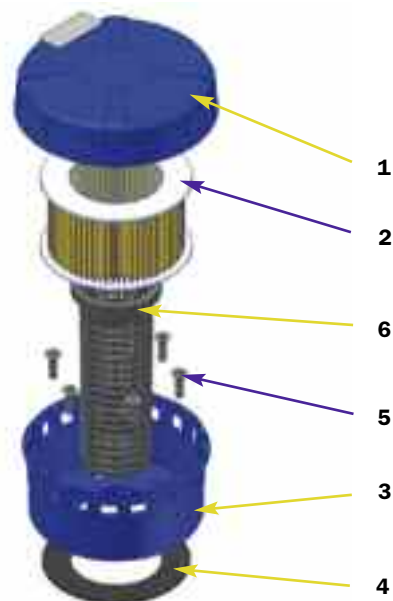

**TAP114 (Materials)**

- 1 - Cover: Nylon
- 2 - Filter element: Impregnated paper
- 3 - Flange: Nylon
- 4 - Seal: NBR
- 5 - Screws: Galvanised Steel
- 6 - Basket: Nylon

## Dimensions

**TAP 114**

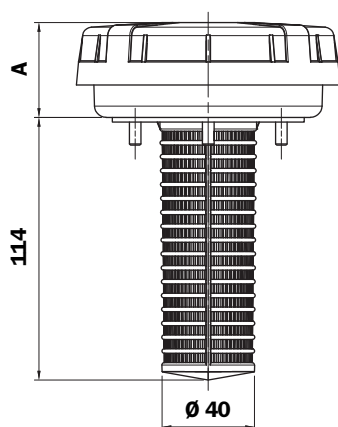

Length	A
1	41
2	56
3	68

**Flow rates with  $\Delta p$ : 0,02 bar**

**Length 1**

Filtration	l/min
10 $\mu m$	1450

**Length 2**

Filtration	l/min
10 $\mu m$	1600

**Weight**

TAP 114 1: 0,185 Kg  
TAP 114 2: 0,200 Kg

**Reservoir  
holes**

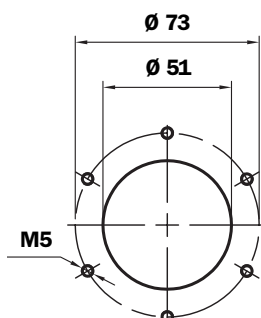
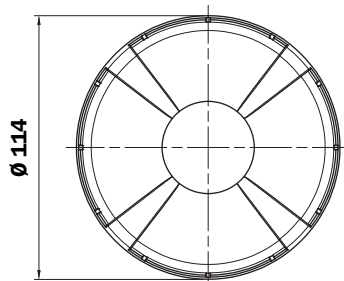

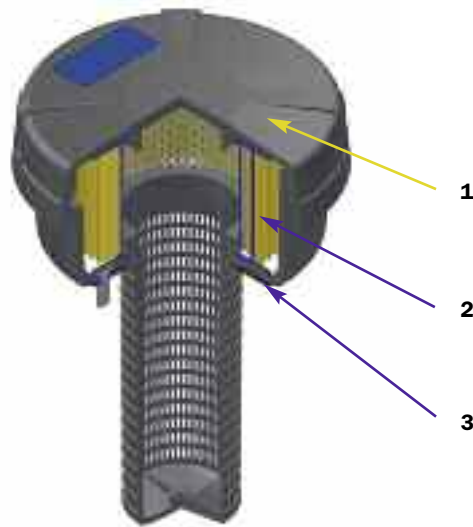

## TAP 114 spare parts

Item.	Description	Q.ty	Filler cap series TAP 114	
1	Complete filler cap	1	See order table	
2	Filter Element	1	See order table	
3	Seal	1	NBR 01026306	FPM 01026332

## Ordering information

**Filler cap**  
**TAP114**

1	2	3	4	5
<input type="checkbox"/>	<input type="checkbox"/>	<input type="checkbox"/>	<input type="checkbox"/>	<input type="checkbox"/>

**Example: TAP114**    3    L10    A    1    P01

**Filter element**  
**A114**

1	2	3
<input type="checkbox"/>	<input type="checkbox"/>	<input type="checkbox"/>

**Example: TAP114**    3    L10    P01

### 1 - Length

1
2
3

### 2 - Filter element

L10    10 µm - Impregnated paper

### 3 - Seal

A    NBR

### 4 - Basket

1    L= 114 mm

### 5 - Options

P01    MP Filtri standard

# Series TAP 115

Nylon oil filler and air breather filler caps



Example  
TAP115

Length 1  
Without indicator



Example  
TAP115

Length 2  
With indicator

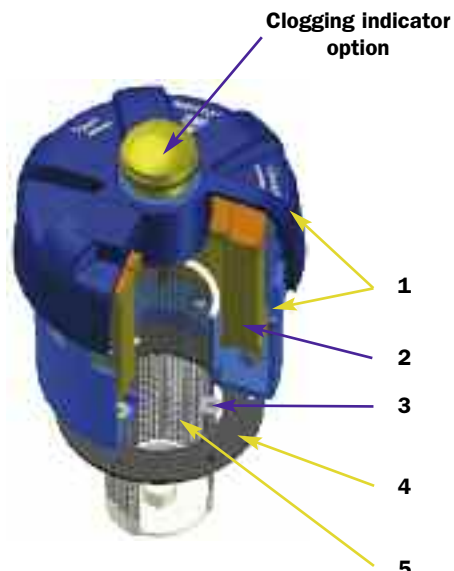

### TAP115 (Materials)

- 1 - Cover/Flange: Nylon
- 2 - Filter element: Microfibre Impregnated paper
- 3 - Seals: NBR  
FPM
- 4 - Screws: Galvanised Steel
- 5 - Basket: Galvanised Steel/Nylon

### Clogging indicator

Set pressure: - 0,062 bar  $\pm$  10 %

Manual reset

## Dimensions

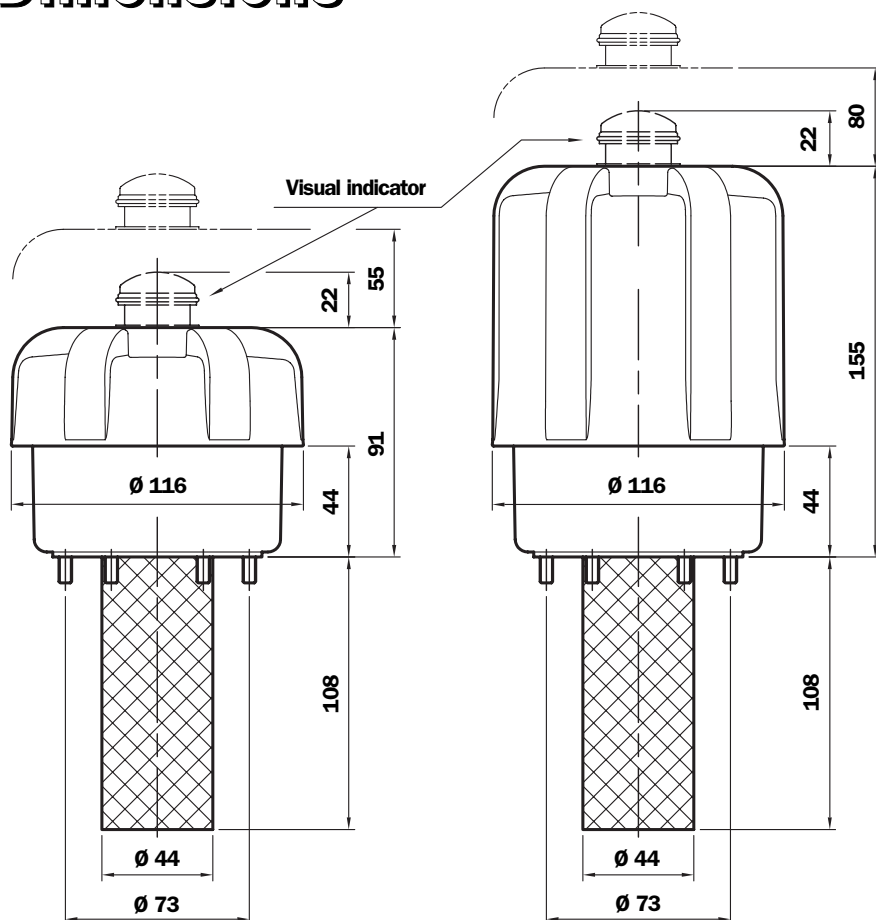

Flow rates with  $\Delta p$ : 0,02 bar

### Length 1

Filtration	l/min
3 $\mu$ m	1600
10 $\mu$ m	2000

### Length 2

Filtration	l/min
3 $\mu$ m	2150
10 $\mu$ m	2150

### Weight

TAP 115 1: 0,460 Kg

TAP 115 2: 0,585 Kg

### Reservoir holes

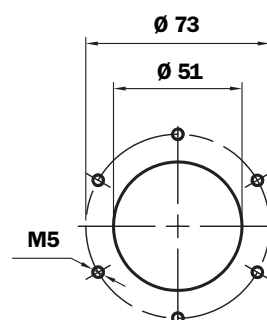

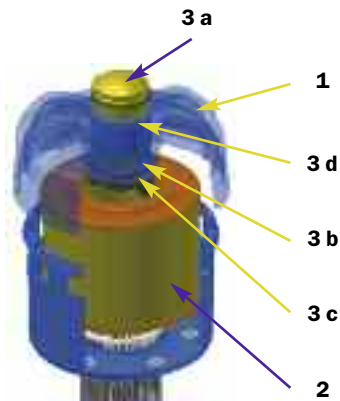

## TAP 115 spare parts

Item.	Description	Q.ty	Filler cap series TAP 115	
1	Complete filler cap	1	See order table	
2	Filter Element	1	See order table	
3	Indicator kit	1	NBR 02005187	FPM 02005188
3a	Visual indicator	1	S62P01	
3b	Seal	1	O-R 3106 Ø 26,64 X 2,62	
3c	Indicator securing screw	1	01022670	
3d	O-R indicator	1	O-R 2112 Ø 28,3 x 1,78	

## Changing the filter element in TAP 115 series filler caps

- 1 Thoroughly clean the filler cap and adjacent parts.
- 2 Unscrew and raise the cover.
- 3 Replace the filter element.
- 4 Screw the cover.



## Ordering information

<b>Filler cap</b>	1	2	3	4	5	6	7
<b>TAP115</b>	<input type="checkbox"/>	<input type="checkbox"/>	<input type="checkbox"/>	<input type="checkbox"/>	<input type="checkbox"/>	<input type="checkbox"/>	<input type="checkbox"/>
<b>Example: TAP115</b>	2	F	A03	A	1	B	P01
<b>Filter element</b>	1	3	7				
<b>A115</b>	<input type="checkbox"/>	<input type="checkbox"/>	<input type="checkbox"/>				
<b>Example: TAP115</b>	2	A03	P01				

### 1 - Length

 1  
 2

### 2 - Connection

 F Flange

### 3 - Filter element

 A03 3 µm - Microfibre  
 L10 10 µm - Impregnated paper

### 4 - Seal

 A NBR  
 V FPM

### 5 - Basket

 0 Without  
 1 L= 120 mm

### 6 - Clogging indicator

 A Without  
 B Clogging indicator

### 7 - Options

 P01 MP Filtri standard