

Cam Operated Directional Valves

These valves may be used to shift the direction of oil flow by depressing the spool by way of a cam.

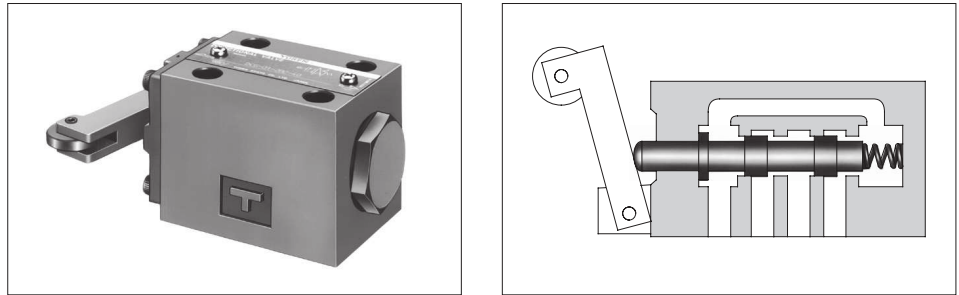

Specifications

Model Numbers		Max. Flow * L/min (U.S.GPM)	Max. Operating Pressure MPa (PSI)	Max. T-Line Pressure MPa (PSI)	Approx. Mass kg (lbs.)	
Threaded Connection	Sub-plate Mounting				DCT Type	DCG Type
DCT-01-2B*-40*	DCG-01-2B*-40*	30 (7.9)	21 (3050)	7 (1020)	1.1 (2.4)	1.1 (2.4)
DCT-03-2B*-50*	DCG-03-2B*-50*	100 (26.4)	25 (3630)	10 (1450)	4.5 (9.9)	3.8 (8.4)

★ Max. flow indicates the ceiling flow which does not affect the normal function (changeover) of valves.

Model Number Designation

F-	DC	T	-01	-2	B	2	-R	-40	*
Special Seals	Series Number	Type of Connection	Valve Size	No. of Valve Position	Spool-Spring Arrangement	Spool Type	Roller Position	Design Number	Design Standards
F: Special seals for phosphate ester type fluids (Omit if not required)	DC: Cam Operated Directional Valve	T: Threaded Connection	01	2	B: Spring Offset	2 3 8		40	None: Japanese Standard "JIS" 80: European Design Standard 90: N. American Design Standard None: Japanese Standard "JIS" & European Design Standard 90: N. American Design Standard
			03					50	
		G: Sub-plate Mounting	01					40	
			03					50	

Sub-plates

Valve Model Numbers	Japanese Standard "JIS"		European Design Standard		N. American Design Standard		Approx. Mass kg (lbs.)
	Sub-plate Model Numbers	Thread Size	Sub-plate Model Numbers	Thread Size	Sub-plate Model Numbers	Thread Size	
DCG-01	DSGM-01-31	Rc 1/8	DSGM-01-3180	1/8 BSP.F	DSGM-01-3190	1/8 NPT	0.8 (1.8)
	DSGM-01X-31	Rc 1/4	DSGM-01X-3180	1/4 BSP.F	DSGM-01X-3190	1/4 NPT	0.8 (1.8)
	DSGM-01Y-31	Rc 3/8	—	—	DSGM-01Y-3190	3/8 NPT	0.8 (1.8)
DCG-03	DSGM-03-41	Rc 3/8	DSGM-03-2180	3/8 BSP.F	DSGM-03-2190	3/8 NPT	3.0 (6.6)
	DSGM-03X-41	Rc 1/2	DSGM-03X-2180	1/2 BSP.F	DSGM-03X-2190	1/2 NPT	3.0 (6.6)
	DSGM-03Y-41	Rc 3/4	DSGM-03Y-2180	3/4 BSP.F	DSGM-03Y-2190	3/4 NPT	4.7 (10.4)

● Sub-plates are available. Specify the sub-plate model number from the table above.
When sub-plates are not used, the mounting surface should have a good machined finish.



Mounting Bolts

Socket head cap screws in the table below are included.

Model Numbers	Socket Head Cap Screw			Tightening Torque Nm (in. lbs)
	Japanese Standard "JIS" European Design Standard	N. American Design Standard	Qty.	
DCT-01	M5 × 45 Lg.	No. 10-24 UNC × 1-3/4 Lg.	2	5-7 (43-60)
DCG-01	M5 × 45 Lg.	No. 10-24 UNC × 1-3/4 Lg.	4	5-7 (43-60)
DCG-03	M6 × 35 Lg.	1/4-20 UNC × 1-1/2 Lg.	4	12-15 (105-130)

Direction of Oil Flow for Roller Position

Model Numbers	Graphic Symbols	Roller Position and Direction of Oil Flow	
		Roller Stroke from Offset Position mm(Inches)	
		Extended(Offset)	Depressed
DCT-01-2B2 DCG-01-2B2		P → B A → T 0 ——— 3.8 ——— 4.6 ——— 9.5 (.150) (.181) (.374)	P → A B → T All ports blocked
DCT-01-2B3 DCG-01-2B3		P → B A → T 0 ——— 3.8 ——— 4.6 ——— 9.5 (.150) (.181) (.374)	P → A B → T All ports open
DCT-01-2B8 DCG-01-2B8		P → B A&T ports blocked 0 ——— 3.8 ——— 9.5 (.150) (.374)	P → A B&T ports blocked
DCT-03-2B2 DCG-03-2B2		P → A B → T 0 ——— 3.4 ——— 3.8 ——— 7 (.134) (.150) (.276)	P → B A → T All ports blocked
DCT-03-2B3 DCG-03-2B3		P → A B → T 0 ——— 3.0 ——— 4.0 ——— 7 (.118) (.157) (.276)	P → B A → T All ports open
DCT-03-2B8 DCG-03-2B8		P → A B&T ports blocked 0 ——— 3.6 ——— 4.7 ——— 7 (.142) (.185) (.276)	P → B A&T ports blocked All ports blocked

Instructions

Valve Type "2B8"

Tank port "T" functions as a drain port. Directly connect it to the reservoir. [Max. allowable back pressure 0.35 MPa (50 PSI)].

Actuation Force

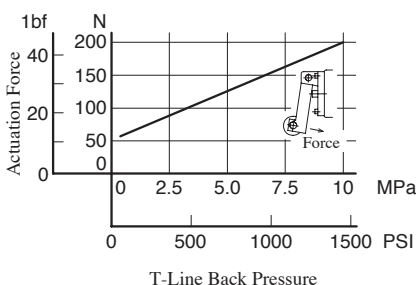

Pressure Drop

Pressure drop curves based on viscosity of 35 mm²/s (164 SSU) and specific gravity of 0.850.

● DCT DCG -01

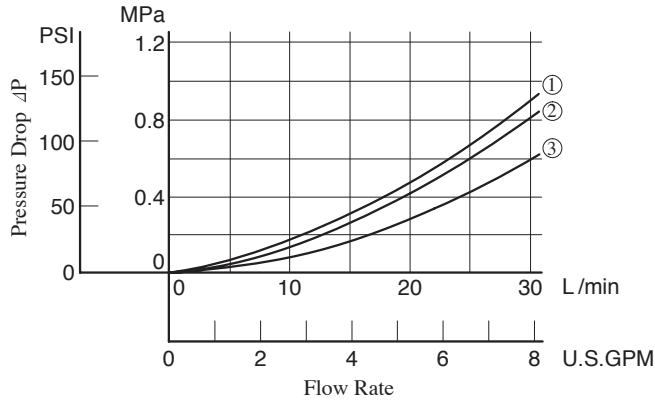

Model Numbers	Pressure Drop Curve No.			
	P→A	B→T	P→B	A→T
DCT-01-2B2	①	①	②	①
DCT-01-2B3	②	—	②	—
DCG-01-2B2	②	②	③	③
DCG-01-2B3	③	—	③	—

● DCT DCG -03

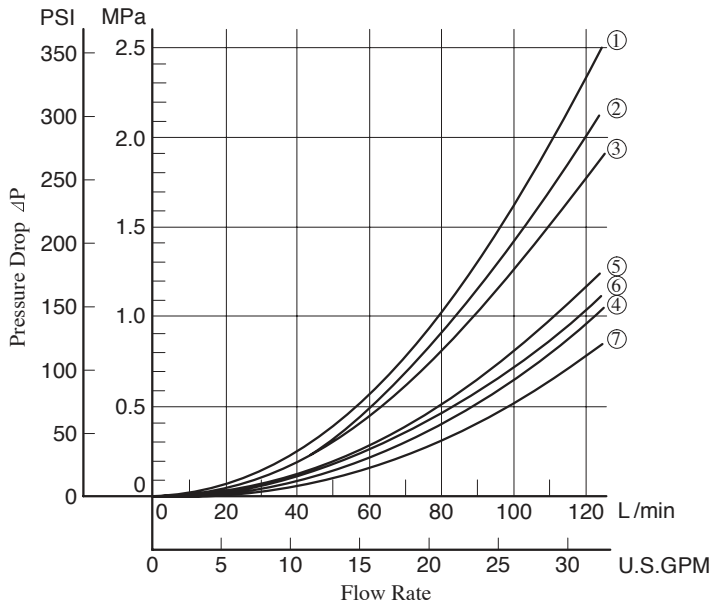

Model Numbers	Pressure Drop Curve No.			
	P→A	B→T	P→B	A→T
DCG-03-2B2	②	①	④	④
DCG-03-2B3	③	②	⑦	⑦
DCG-03-2B8	⑥	—	⑤	—

● For any other viscosity, multiply the factors in the table below.

Viscosity	mm ² /s	15	20	30	40	50	60	70	80	90	100
	SSU		77	98	141	186	232	278	324	371	417
Factor		0.81	0.87	0.96	1.03	1.09	1.14	1.19	1.23	1.27	1.30

● For any other specific gravity (G'), the pressure drop (ΔP') may be obtained from the formula below.

$$\Delta P' = \Delta P (G'/G)$$

where, ΔP is a value on the above chart and G is 0.850.



DCT-01-2B*-*-40/4080/4090

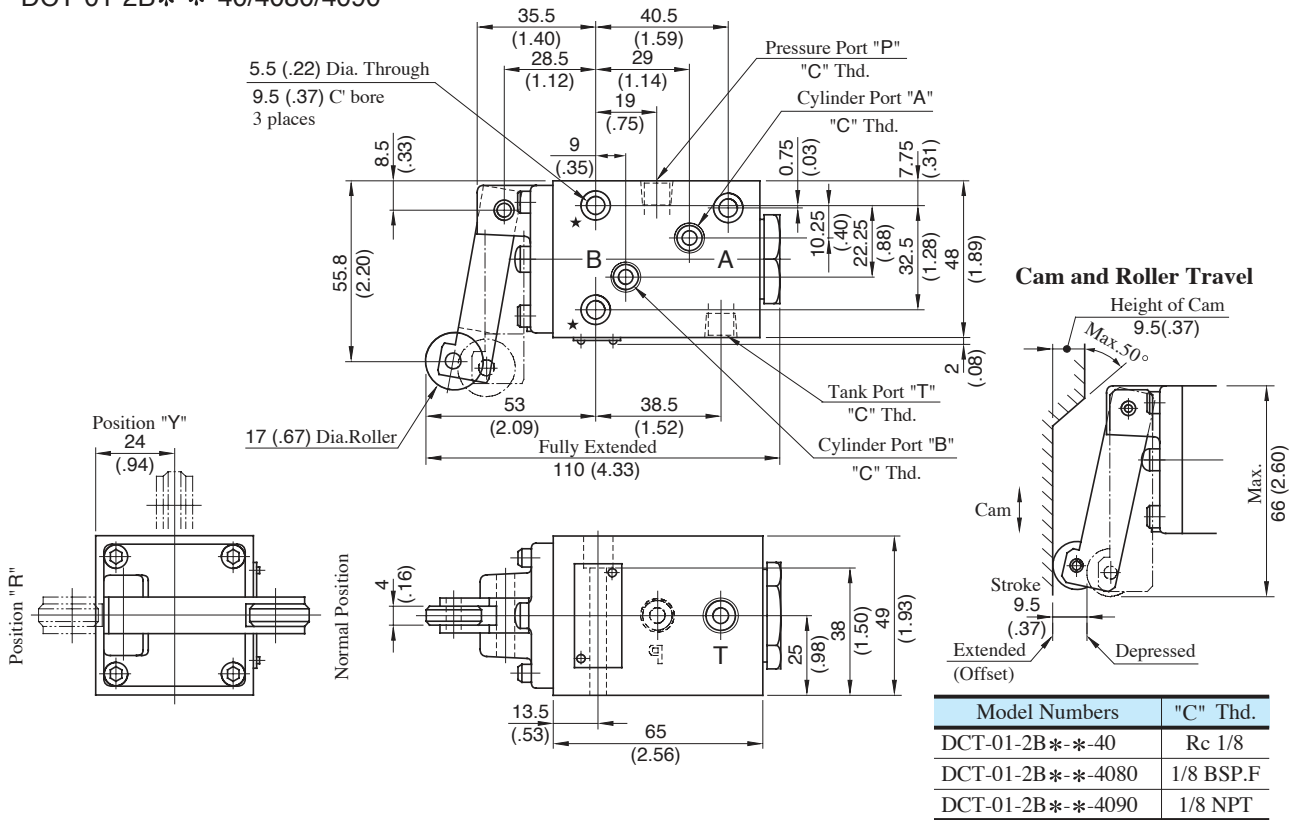

Note: When mounting the valve, be sure to use two mounting holes marked with ★.

DIMENSIONS IN MILLIMETRES (INCHES)

DCT-03-2B*-*-50/5080/5090

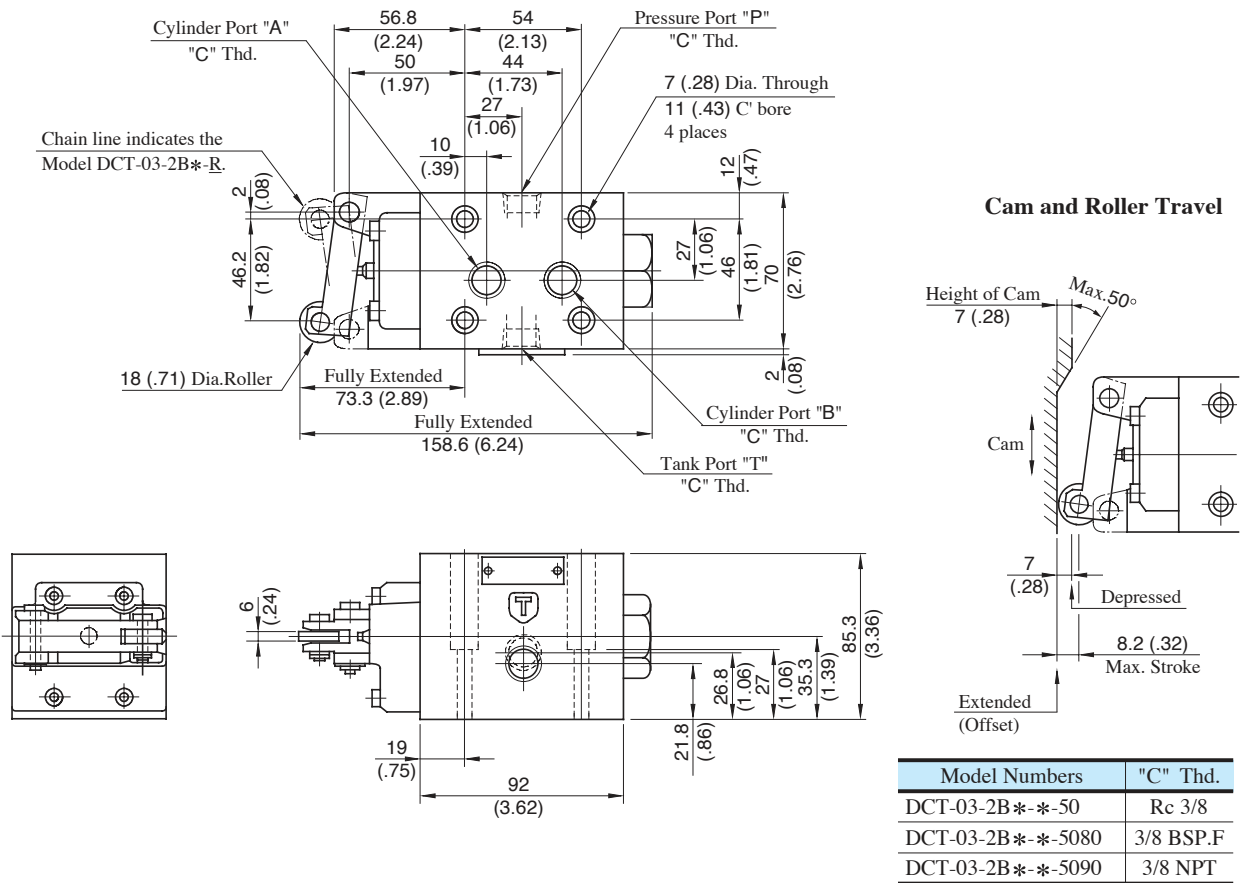

DCG-01-2B*-**-40/4090

Mounting Surface: ISO 4401-AB-03-4-A

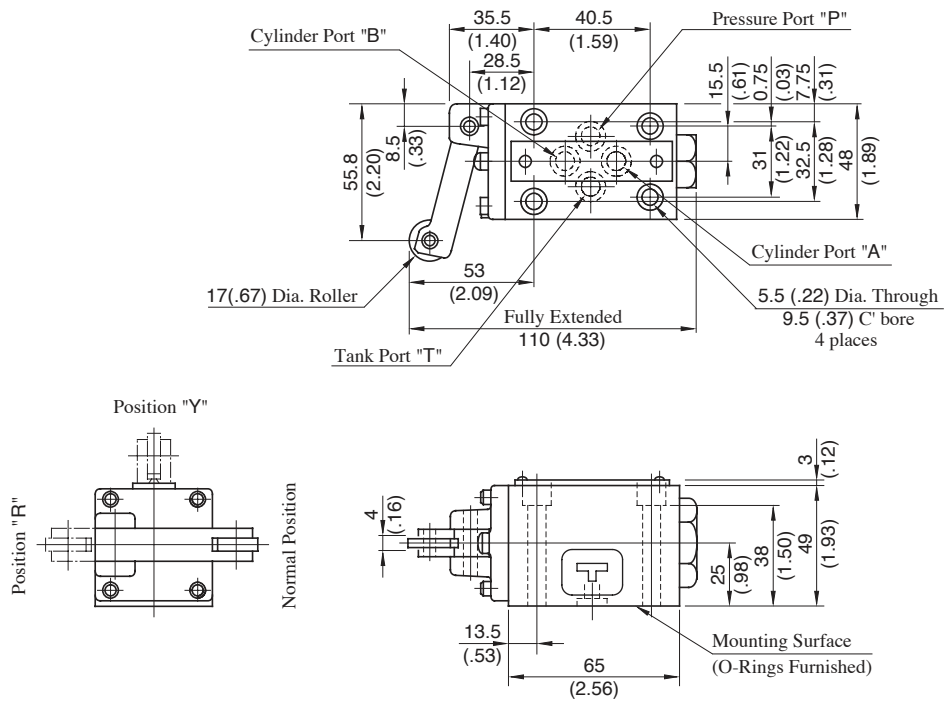

Note1: For the cam and roller travel, see DCT-01 in the [previous page](#).

Note2: For the valve mounting surface dimensions, see the dimensional drawing of the sharable sub-plate in [page 356](#).

DIMENSIONS IN MILLIMETRES (INCHES)

Mounting Surface: ISO 4401-AC-05-4-A

DCG-03-2B*-**-50/5090

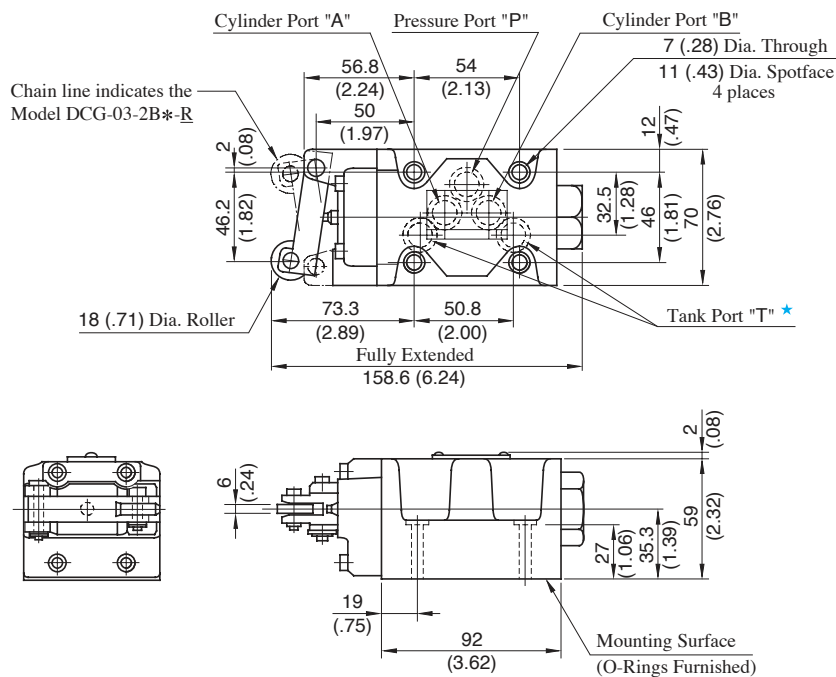

★. Although the tank port is shown on the left in our sub-plate, either may be used.

Note1: For the cam and roller travel, see DCT-03 in the [previous page](#).

Note2: For the valve mounting surface dimensions, see the dimensional drawing of the sharable sub-plate in [page 373](#).



■ List of Seals

DCT-01-2B*-*-40/4080/4090
 DCG-01-2B*-*-40/4090

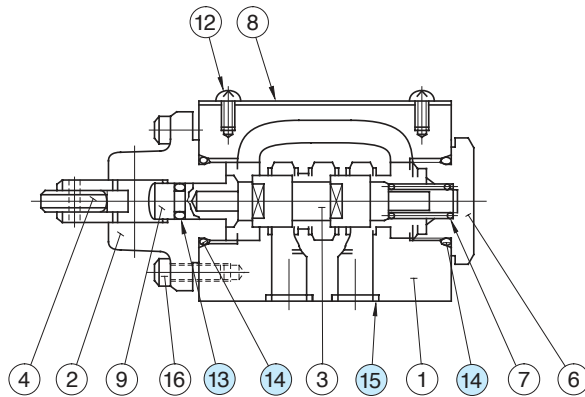

● List of Seal Kit No.

Item	Name of Parts	Part Numbers	Quantity	
			DCT-01	DCG-01
13	O-Ring	SO-NA-P5	1	1
14	O-Ring	SO-NB-P18	2	2
15	O-Ring	SO-NB-P9	0	4

Valve Model Numbers	Seal Kit Numbers
DCT-01-2B*-*-40/4080/4090	KS-DCT-01-40
DCG-01-2B*-*-40/4090	KS-DCG-01-40

Note: When ordering the o-rings, please specify the seal kit number from the table right.

DCT-03-2B*-*-50/5080/5090
 DCG-03-2B*-*-50/5090

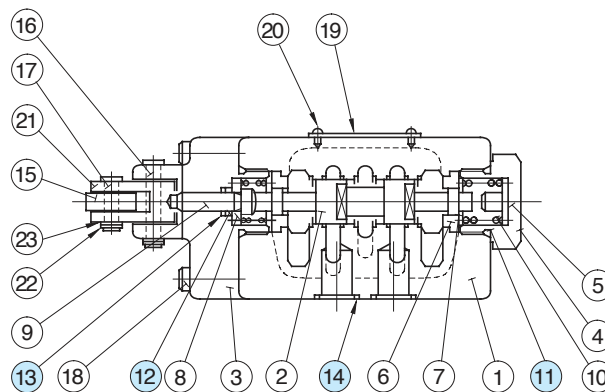

● List of Seal Kit No.

Item	Name of Parts	Part Numbers	Quantity	
			DCT-03	DCG-03
11	O-Ring	SO-NB-P21	2	2
12	O-Ring	SO-NA-P6	1	1
13	Back Up Ring	SO-BE-P6	1	1
14	O-Ring	SO-NB-A014	0	5

Valve Model Numbers	Seal Kit Numbers
DCT-03-2B*-*-50/5080/5090	KS-DCT-03-50
DCG-03-2B*-*-50/5090	KS-DCG-03-50

Note: When ordering the seals, please specify the seal kit number from the table right.