

Multi Purpose Control Valves

The Yuken Multi-Purpose Control Valves Comply with The Needs of Reducing Cost and Size of Your Machine

YUKEN's Multi Purpose Control Valves are compound valves composed of the main valve having four poppets, 1/8 Solenoid Operated Directional Valves for pilot and Pilot Selector Valves. This valve is multifunctionalized by having individual poppet had functions such as directional control, flow control or pressure control according to the combination of the main valve and pilot selector valve.

Features

Multi-purpose control valves

The valves combine three functions of directional control, flow control and of pilot operated check valve (or counterbalance valve). The valves contribute for reducing a number of valves in applications and space for installation and then eventually leads to reduction in size and cost of your machines.

Quick response, High reliability

Changeover response time is very quick as the valves are poppet type, there is no over-lap. No hydraulic lock occurs as there is no leakage of pressurised oil from the seat parts.

Easy to reduce shock in your hydraulic system

By selecting proper diameter of orifice for pilot, the open/close timing of the flow passage can be set freely. Therefore, smooth starting and stopping of actuator can be done combined with using shockless type poppet. Noise of ON/OFF and vibration of piping in hydraulic system can be also reduced.

For regenerative circuit

4 position-4 way type, which is to compose regenerative circuit, is available. By adopting regenerative circuit, gaining fast feed speed by using smaller volume pump is possible. Therefore saving electric power of system is possible.

The mounting dimensions are conformed with ISO standard

The valves are interchangeable with our conventional valves in mounting.

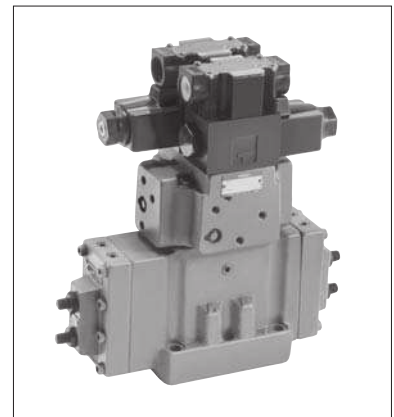
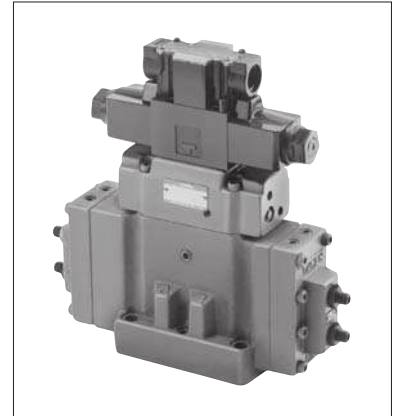

E

Multi Purpose Control Valves

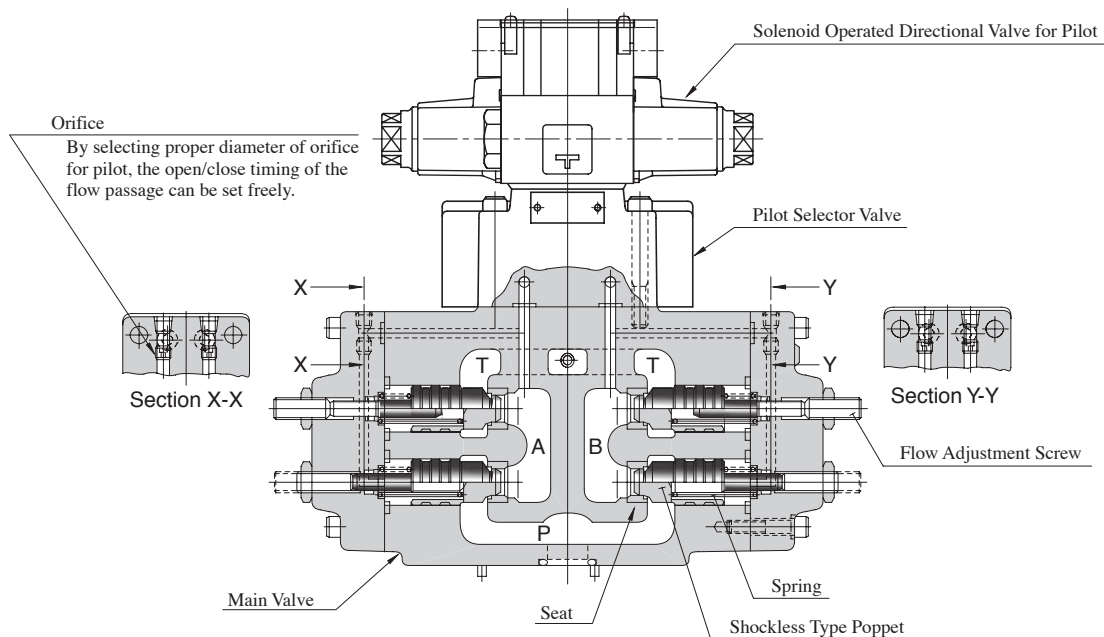

Specifications

Model Numbers	Max. Flow L/min (U.S.GPM)	Max. Operating Pressure MPa (PSI)	Max. Pilot Pressure MPa (PSI)	Max. T-Line Back Pres. MPa (PSI)	Pressure Adj. Range of Counterbalance MPa (PSI)	Ratio of Poppet Area (Seat Area: Annular Area)		Approx. Mass kg (lbs.)
						Direction & Flow Control	Pressure Control	
DSLHG-04-1-*-13*	150 (39.6)	25 (3630)	25 (3630)	16 (2320)	—	1:1	—	15 (33)
DSLHG-04-2-*-13*								15 (33)
DSLHG-04-3-*-13*								19 (42)
DSLHG-04-4-*-13*	150 {100}* (39.6 {26.4})	25 (3630)	25 (3630)	16 (2320)	Refer to Model No. Designation	1:1	24:1	20 (44)
DSLHG-04-5-*-13*								22.5 (50)
DSLHG-06-1-*-13*	300 (79.3)	25 (3630)	25 (3630)	16 (2320)	—	1:1	—	26.5 (59)
DSLHG-06-2-*-13*								26.5 (59)
DSLHG-06-3-*-13*								28 (62)
DSLHG-06-4-*-13*	300 {200}* (79.3 {52.8})	25 (3630)	25 (3630)	16 (2320)	Refer to Model No. Designation	1:1	24:1	31 (68)
DSLHG-06-5-*-13*								34.5 (76)
DSLHG-10-1-*-13*	500 (132)	25 (3630)	25 (3630)	16 (2320)	—	1:1	—	59 (130)
DSLHG-10-2-*-13*								59 (130)
DSLHG-10-3-*-13*								62 (137)
DSLHG-10-4-*-13*	500 {300}* (132 {79.3})	25 (3630)	25 (3630)	16 (2320)	Refer to Model No. Designation	1:1	24:1	63.5 (140)
DSLHG-10-5-*-13*								67 (148)

★ In case of counterbalance function line, maximum flow is limited to the values in brackets.

Solenoid Ratings

Refer to Pilot Valve (DSG-01 Series Solenoid Operated Directional Valve) Solenoid Ratings on [page 345](#).

Model Number Designation

F-	DSLH	G	-04	-4	A	-B		
Special Seals	Series Number	Type of Mounting	Valve Size	Type of Pilot Control	Counterbalance Function	Pressure Adj. Range of Counterbalance MPa (PSI)		
F: For phosphate ester type fluids (Omit if not required)	DSLH: Multi-Purpose Control Valve	G: Sub-plate Mounting	04	1	—	—		
				2				
				3				
			06	4	A : AT Line W : AT & BT Lines	B : * ^{★1} - 7 (* ^{★1} - 1020) H : 6 - 25 (870 - 3630)		
				5				
				1			—	—
				2				
				3				
				10			4	A : AT Line W : AT & BT Lines
			5					
			See page 462 for functions and purpose of use.					

★1. See "Min. Adjustment Pressure", [page 464](#), for information on minimum adjustment pressure.

Sub-plate

Valve Model Numbers	Japanese Standard "JIS"			European Design Standard			N. American Design Standard		
	Sub-plate Model Numbers	Thread Size	Approx. Mass kg (lbs.)	Sub-plate Model Numbers	Thread Size	Approx. Mass kg (lbs.)	Sub-plate Model Numbers	Thread Size	Approx. Mass kg (lbs.)
DSLHG-04	DHGM-04-20	Rc 1/2	4.4 (9.7)	DHGM-04-2080	1/2 BSP.F	4.4 (9.7)	DHGM-04-2090	1/2 NPT	4.4 (9.7)
	DHGM-04X-20	Rc 3/4	4.1 (9.0)	DHGM-04X-2080	3/4 BSP.F	4.1 (9.0)	DHGM-04X-2090	3/4 NPT	4.1 (9.0)
DSLHG-06	DHGM-06-50	Rc 3/4	7.4 (16.3)	DHGM-06-5080	3/4 BSP.F	8.5 (18.7)	DHGM-06-5090	3/4 NPT	7.4 (16.3)
	DHGM-06X-50	Rc 1	7.4 (16.3)	DHGM-06X-5080	1 BSP.F	8.5 (18.7)	DHGM-06X-5090	1 NPT	7.4 (16.3)
DSLHG-10	DHGM-10-40	Rc 1-1/4	21.5 (47.4)	DHGM-10-4080	1-1/4 BSP.F	21.5 (47.4)	DHGM-10-4090	1-1/4 NPT	21.5 (47.4)
	DHGM-10X-40	Rc 1-1/2	21.5 (47.4)	DHGM-10X-4080	1-1/2 BSP.F	21.5 (47.4)	DHGM-10X-4090	1-1/2 NPT	21.5 (47.4)

- Sub-plates are available. Specify the sub-plate model number from the table above. When sub-plates are not used, the mounting surface should have a good machined finish.
- These sub-plates are sharable with those for DSHG Series Solenoid Controlled Pilot Operated Directional Valve. For dimensions, see pages 401 to 403.

Mounting Bolts

Socket head cap screws in the table below are included.

Model Numbers	Socket Head Cap Screw			
	Japanese Standard "JIS" and European Design Standard	N. American Design Standard	Qty.	Tightening Torque Nm (In. lbs.)
DSLHG-04	M6 × 40 Lg.	1/4-20 UNC × 1-1/2 Lg.	2	12-15 (106-133)
	M10 × 45 Lg.	3/8-16 UNC × 1-3/4 Lg.	4	58-72 (513-637)
DSLHG-06	M12 × 60 Lg.	1/2-13 UNC × 2-1/2 Lg.	6	100-123 (885-1089)
DSLHG-10	M20 × 75 Lg.	3/4-10 UNC × 3 Lg.	6	473-585 (4186-5177)

-E	T	-A100	-C	-N	-13	*
Pilot Connection	Drain Connection ^{★2}	Coil Type	Manual Override	Electrical Conduit Connection	Design Number	Design Standards
None: Internal Pilot	None: External Drain	AC: A100 A120 A200 A240	None: Manual Override Pin	None: Terminal Box Type	13	None: Japanese Std. "JIS" 90: N.American Design Std.
		DC: D12 D24 D48			13	
E: External Pilot	T: Internal Drain	R: (AC→DC) R100 R200	C: Push Button & Lock Nut (Options)	N: Plug-in Connector Type	13	None: Japanese Std. "JIS" & European Design Std. 90: N.American Design Std.

★2. In case of lines with counterbalance function (-4 $\frac{A}{W}$, -5 $\frac{A}{W}$), External Drain must be selected for Drain Connection.

The coil type numbers in the shaded column are handled as optional extras. In case these coils are required to be chosen, please confirm the time of delivery with us before ordering.

Function and Purpose of Use

Type of Pilot Control	Model No.	Graphic Symbols	Function			Purpose of Use															
			Directional Control	Flow Control	Pilot Operated Check Valve / Pressure Control																
Type "1"	DSLHG-**-1		 <table border="1"> <tr> <th>Position</th> <th>#1</th> <th>#2</th> <th>#3</th> </tr> <tr> <td>SOL a</td> <td>ON</td> <td>OFF</td> <td>OFF</td> </tr> <tr> <td>SOL b</td> <td>OFF</td> <td>OFF</td> <td>ON</td> </tr> </table>	Position	#1	#2	#3	SOL a	ON	OFF	OFF	SOL b	OFF	OFF	ON			<ul style="list-style-type: none"> Functions as Three Position Four-Way Valve (Spring Centred Model). 			
	Position	#1	#2	#3																	
SOL a	ON	OFF	OFF																		
SOL b	OFF	OFF	ON																		
Type "2"	DSLHG-**-2		 <table border="1"> <tr> <th>Position</th> <th>#1</th> <th>#2</th> <th>#3</th> </tr> <tr> <td>SOL a</td> <td>ON</td> <td>OFF</td> <td>OFF</td> </tr> <tr> <td>SOL b</td> <td>OFF</td> <td>OFF</td> <td>ON</td> </tr> </table>	Position	#1	#2	#3	SOL a	ON	OFF	OFF	SOL b	OFF	OFF	ON	 Both Metre-in and Metre-out are possible	 To get a function of pilot operated check valve, the following conditions should be fulfilled. <ul style="list-style-type: none"> Internal pilot type ("P" port pressure) \geq ("A""B" ports pressure) External pilot type (Pilot pressure) \geq ("A""B" ports pressure) 	<ul style="list-style-type: none"> Functions as Three Position Four-Way Valve (Spring Centred Model) as well as Two Position Valve which uses positions #1 and #3. Effective especially when the actuator has inertia force. 			
	Position	#1	#2	#3																	
SOL a	ON	OFF	OFF																		
SOL b	OFF	OFF	ON																		
Type "3"	DSLHG-**-3		 <table border="1"> <tr> <th>Position</th> <th>#1</th> <th>#2</th> <th>#3</th> <th>#4</th> </tr> <tr> <td>SOL a</td> <td>ON</td> <td>OFF</td> <td>ON</td> <td>OFF</td> </tr> <tr> <td>SOL b</td> <td>OFF</td> <td>OFF</td> <td>ON</td> <td>ON</td> </tr> </table>	Position	#1	#2	#3	#4	SOL a	ON	OFF	ON	OFF	SOL b	OFF	OFF	ON	ON			<ul style="list-style-type: none"> Functions as Four Position Four-Way Valve. Regenerative circuit can be constructed at the Position #3.
	Position	#1	#2	#3	#4																
SOL a	ON	OFF	ON	OFF																	
SOL b	OFF	OFF	ON	ON																	
Type "4"	DSLHG-**-4A		 <table border="1"> <tr> <th>Position</th> <th>#1</th> <th>#2</th> <th>#3</th> </tr> <tr> <td>SOL a</td> <td>ON</td> <td>OFF</td> <td>OFF</td> </tr> <tr> <td>SOL b</td> <td>OFF</td> <td>OFF</td> <td>ON</td> </tr> </table>	Position	#1	#2	#3	SOL a	ON	OFF	OFF	SOL b	OFF	OFF	ON			<ul style="list-style-type: none"> Pressure control function (counterbalance valve) has been added to Type "2" to make this type. 			
	Position	#1	#2	#3																	
SOL a	ON	OFF	OFF																		
SOL b	OFF	OFF	ON																		
	DSLHG-**-4W		 <table border="1"> <tr> <th>Position</th> <th>#1</th> <th>#2</th> <th>#3</th> </tr> <tr> <td>SOL a</td> <td>ON</td> <td>OFF</td> <td>OFF</td> </tr> <tr> <td>SOL b</td> <td>OFF</td> <td>OFF</td> <td>ON</td> </tr> </table>	Position	#1	#2	#3	SOL a	ON	OFF	OFF	SOL b	OFF	OFF	ON			<ul style="list-style-type: none"> Used to control the back pressure of the actuator. 			
Position	#1	#2	#3																		
SOL a	ON	OFF	OFF																		
SOL b	OFF	OFF	ON																		
Type "5"	DSLHG-**-5A		 <table border="1"> <tr> <th>Position</th> <th>#1</th> <th>#2</th> <th>#3</th> <th>#4</th> </tr> <tr> <td>SOL a</td> <td>ON</td> <td>OFF</td> <td>ON</td> <td>OFF</td> </tr> <tr> <td>SOL b</td> <td>OFF</td> <td>OFF</td> <td>ON</td> <td>ON</td> </tr> </table>	Position	#1	#2	#3	#4	SOL a	ON	OFF	ON	OFF	SOL b	OFF	OFF	ON	ON			<ul style="list-style-type: none"> Pressure control function (counterbalance valve) has been added to Type "3" to make this type.
	Position	#1	#2	#3	#4																
SOL a	ON	OFF	ON	OFF																	
SOL b	OFF	OFF	ON	ON																	
	DSLHG-**-5W		 <table border="1"> <tr> <th>Position</th> <th>#1</th> <th>#2</th> <th>#3</th> <th>#4</th> </tr> <tr> <td>SOL a</td> <td>ON</td> <td>OFF</td> <td>ON</td> <td>OFF</td> </tr> <tr> <td>SOL b</td> <td>OFF</td> <td>OFF</td> <td>ON</td> <td>ON</td> </tr> </table>	Position	#1	#2	#3	#4	SOL a	ON	OFF	ON	OFF	SOL b	OFF	OFF	ON	ON			<ul style="list-style-type: none"> Used to control the back pressure of the actuator.
Position	#1	#2	#3	#4																	
SOL a	ON	OFF	ON	OFF																	
SOL b	OFF	OFF	ON	ON																	

Instructions

Pilot Pressure

Pilot pressure of external pilot drain models must always exceed the pressure of the main pressure port "P".

Pilot Drain Port

Avoid connecting the pilot drain port to a line with possible surge pressure.

Drain Connection when with Counterbalance Function

When a valve having counterbalance function is used with internal drain type, the counterbalance pilot valve is subjected to pressure fluctuation and the pressure setting becomes unstable. For this reason, be sure to use external drain type valve.

Flow Adjustment

To perform the flow adjustment, loosen the lock nut, then turn the flow adjustment screw clockwise to decrease the flow. Be sure to re-tighten the lock nut after the adjustment.

Pressure Adjustment

To perform the pressure adjustment, loosen the lock nut, then turn the pressure adjustment screw clockwise to increase the pressure. Be sure to re-tighten the lock nut after the adjustment.

Min. Controlled Flow for Types "2" and "4A" at The Time of Metre-out Control

Minimum controlled flow at the time of metre-out control is limited (this does not happen during metre-in control) as shown in the figure below only in the case of pilot control types "2" (DSLHG- *-2) and "4A" (DSLHG- *-4A).

Min. Controlled Flow for Types "2" and "4A" at The Time of Metre-out Control

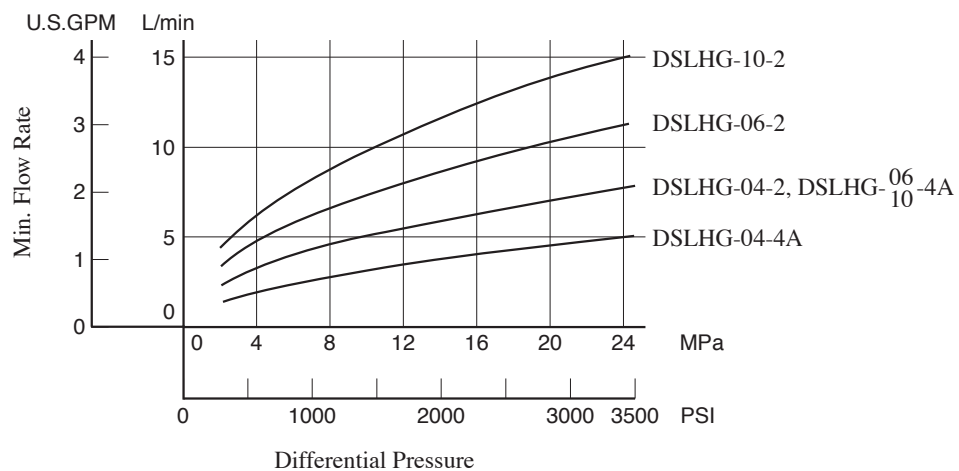

Hydraulic Fluid: Viscosity 35 mm²/s (164 SSU), Specific Gravity 0.850

Pressure Drop

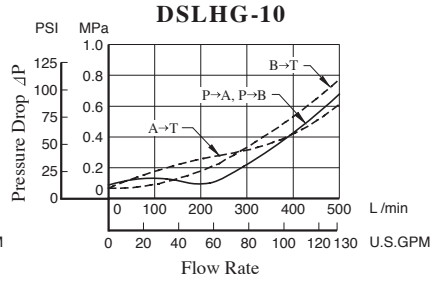
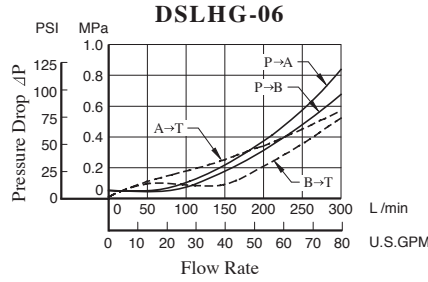
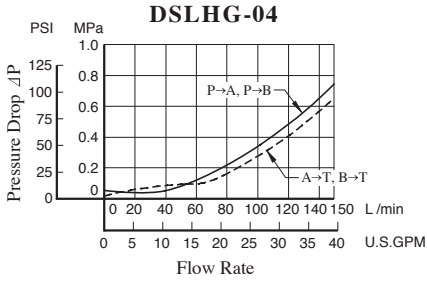

- For any other viscosity, multiply the factors in the table below.

Viscosity	mm ² /s	15	20	30	40	50	60	70	80	90	100
		SSU	77	98	141	186	232	278	324	371	417
	Factor	0.81	0.87	0.96	1.03	1.09	1.14	1.19	1.23	1.27	1.30

- For any other specific gravity (G'), the pressure drop (ΔP') may be obtained from the formula below.

$$\Delta P' = \Delta P (G'/0.850)$$

Flow vs. Adjustment Revolutions

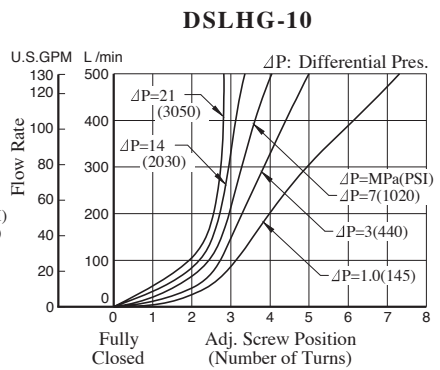
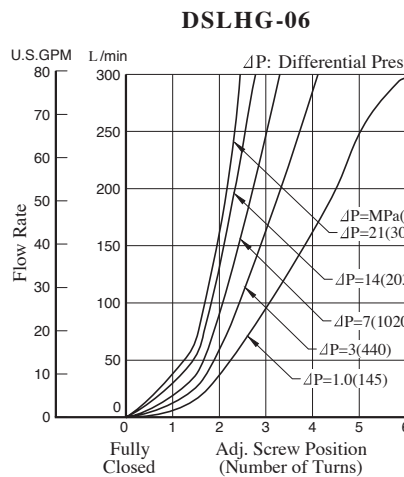
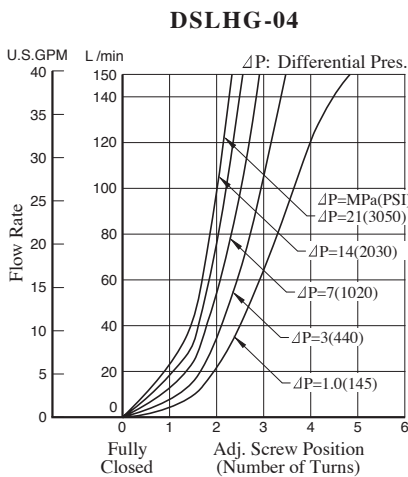

Minimum Adjustment Pressure

Because the minimum adjustment pressure varies with the tank line back pressure, add the tank line back pressure to the value on the following lines.

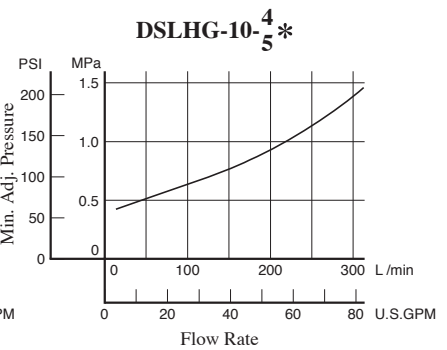
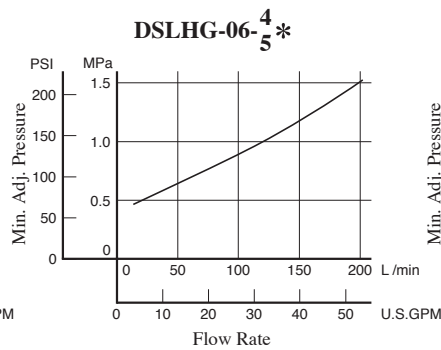
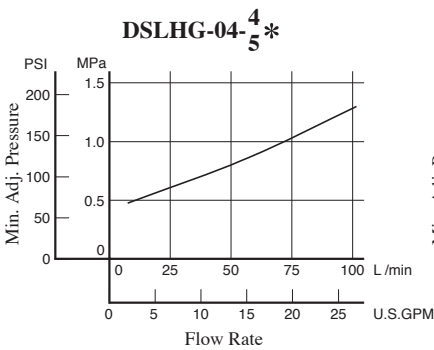

DSLHG-04- $\frac{1}{2}$ -*-13/1390

Terminal Box Type

Mounting Surface:
ISO4401-AD-07-4-A

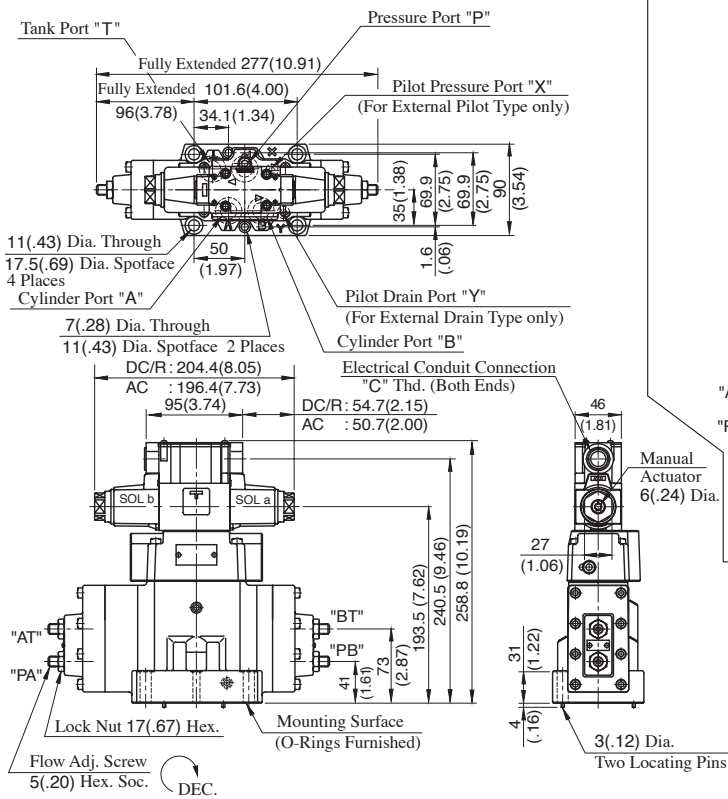

DSLHG-04-3-*-13/1390

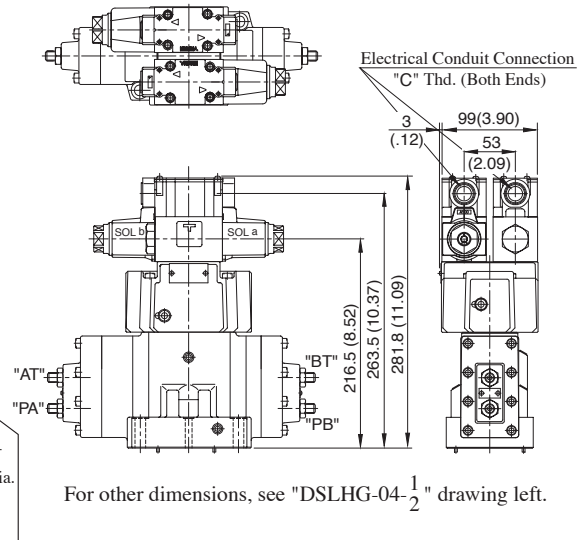

Model Numbers	"C" Thd.
DSLHG-04-*-*-13	G 1/2
DSLHG-04-*-*-1390	1/2 NPT

DIMENSIONS IN MILLIMETRES (INCHES)

DSLHG-04-4W-*-*-13/1390

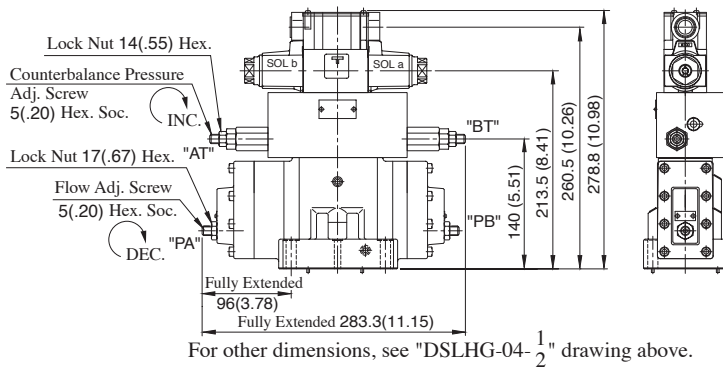

DSLHG-04-4A-*-*-13/1390

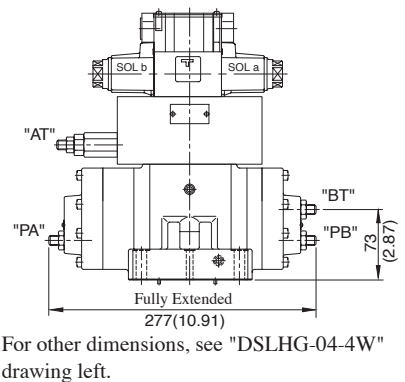

DSLHG-04-5W-*-*-13/1390

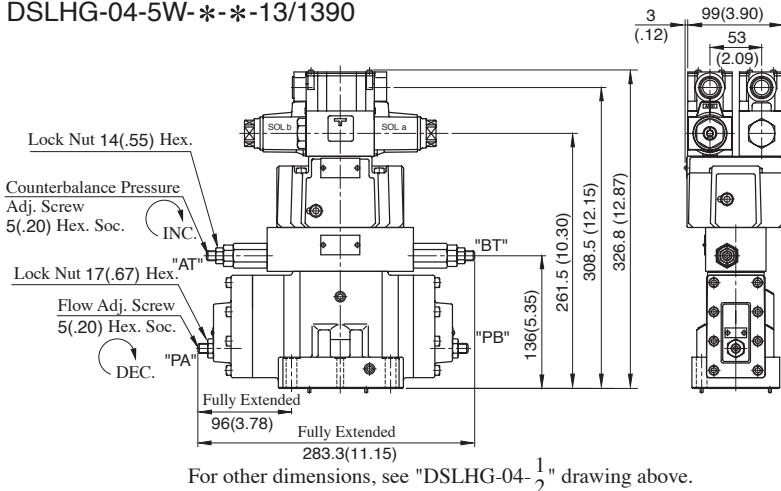

DSLHG-04-5A-*-*-13/1390

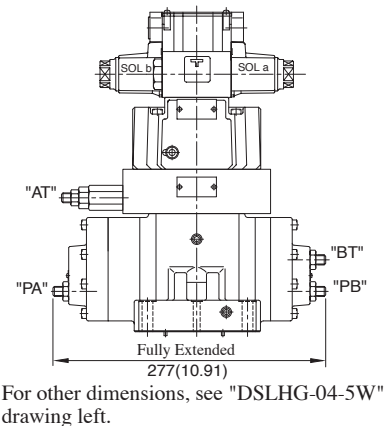

DSLHG-04- $\frac{1}{2}$ -*-N-13/1390

Plug-in Connector Type

Mounting Surface:
ISO4401-AD-07-4-A

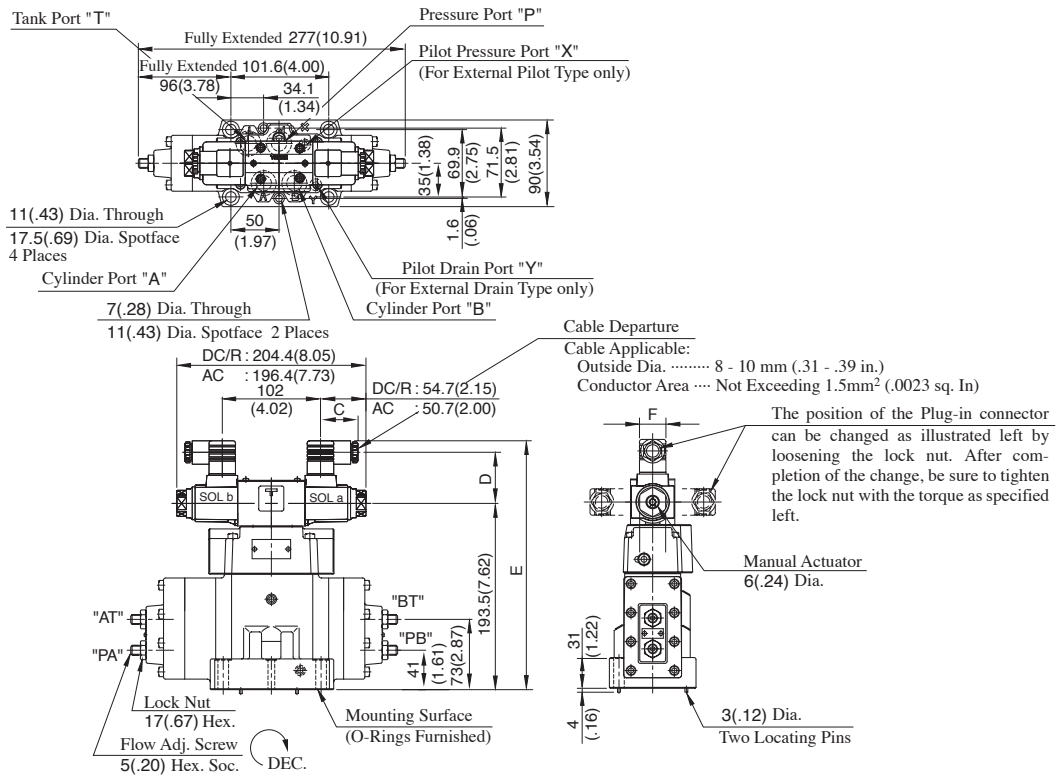

Model Numbers	Dimensions mm (Inches)			
	C	D	E	F
DSLHG-04-*-A*-N	39 (1.54)	53 (2.09)	258.5(10.18)	27.5 (1.08)
DSLHG-04-*-D*-N	39 (1.54)	64 (2.52)	269.5(10.61)	27.5 (1.08)
DSLHG-04-*-R*-N	53 (2.09)	57.2(2.25)	272.5(10.73)	34 (1.34)

DSLHG-04-3-*-N-13/1390

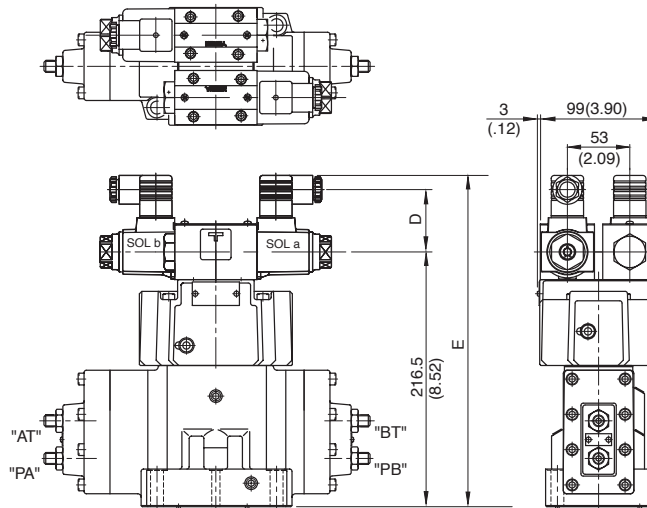

Model Numbers	Dimensions mm (Inches)	
	D	E
DSLHG-04-3-A*-N	53 (2.09)	281.5 (11.08)
DSLHG-04-3-D*-N	64 (2.52)	292.5 (11.52)
DSLHG-04-3-R*-N	57.2 (2.25)	299.5 (11.63)

DIMENSIONS IN
MILLIMETRES (INCHES)

For other dimensions, see "DSLHG-04- $\frac{1}{2}$ -*-N" drawing above.

Plug-in Connector Type

Mounting Surface:
ISO4401-AD-07-4-A

DSLHG-04-4W-*-N-13/1390

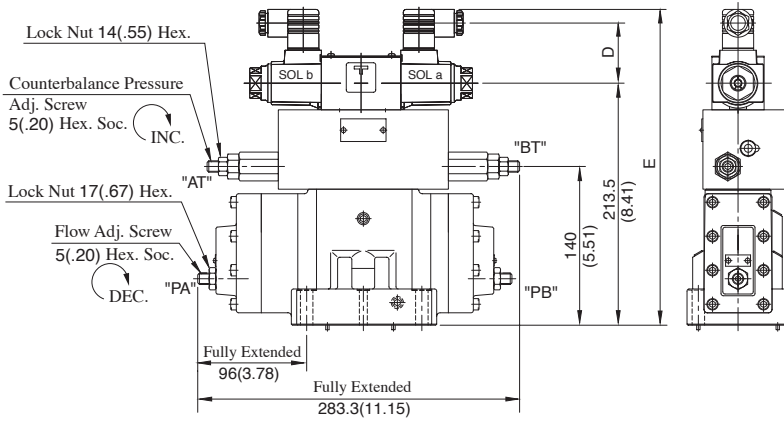

Model Numbers	Dimensions mm (Inches)	
	D	E
DSLHG-04-4W-*-A*-N	53 (2.09)	278.5 (10.96)
DSLHG-04-4W-*-D*-N	64 (2.52)	289.5 (11.40)
DSLHG-04-4W-*-R*-N	57.2 (2.25)	292.5 (11.52)

For other dimensions, see DSLHG-04- $\frac{1}{2}$ -*-N on the [previous page](#).

DSLHG-04-4A-*-N-13/1390

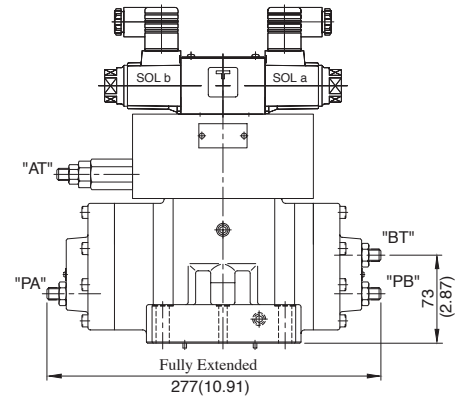

For other dimensions, see
"DSLHG-04-4W-*-N" drawing left.

DSLHG-04-5W-*-N-13/1390

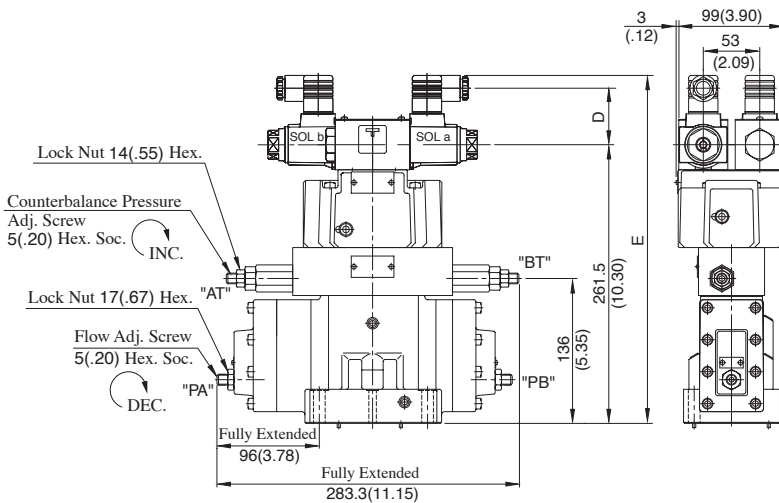

Model Numbers	Dimensions mm (Inches)	
	D	E
DSLHG-04-5W-*-A*-N	53 (2.09)	326.5 (12.85)
DSLHG-04-5W-*-D*-N	64 (2.52)	337.5 (13.28)
DSLHG-04-5W-*-R*-N	57.2 (2.25)	340.5 (13.41)

For other dimensions, see DSLHG-04- $\frac{1}{2}$ -*-N on the [previous page](#).

DSLHG-04-5A-*-N-13/1390

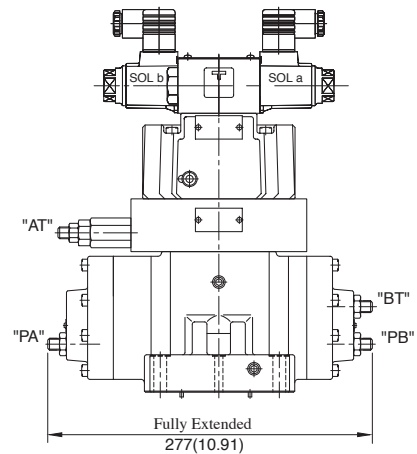

For other dimensions, see
"DSLHG-04-5W-*-N" drawing left.

**DIMENSIONS IN
MILLIMETRES (INCHES)**

Terminal Box Type

Mounting Surface:
ISO4401-AE-08-4-A

DSLHG-06- $\frac{1}{2}$ -*-13/1390

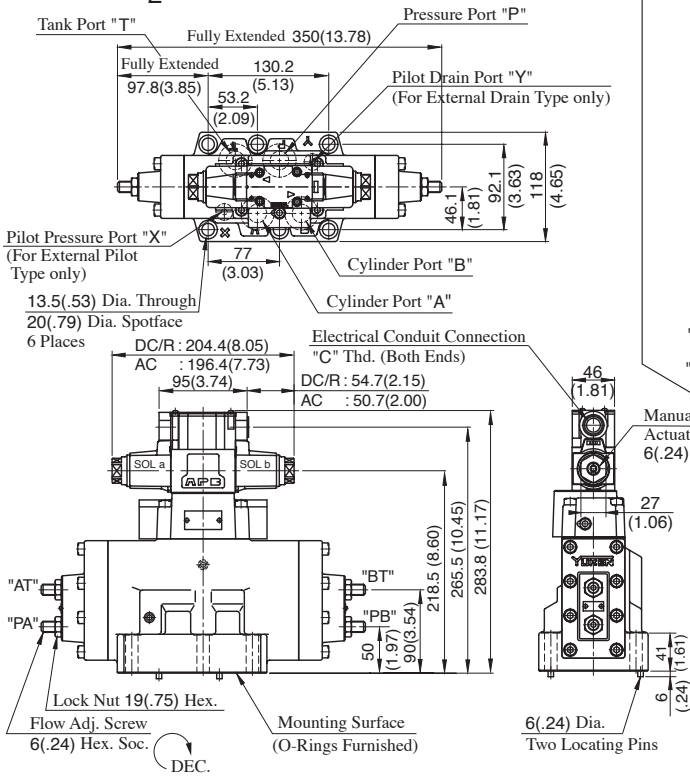

DSLHG-06-3-*-13/1390

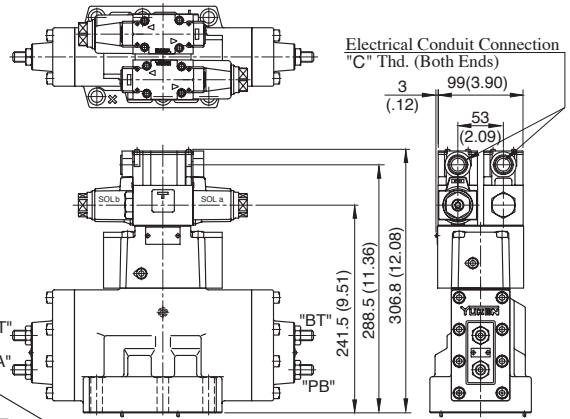

For other dimensions, see "DSLHG-06- $\frac{1}{2}$ " drawing left.

Model Numbers	"C" Thd.
DSLHG-06-*-*-13	G 1/2
DSLHG-06-*-*-1390	1/2 NPT

DIMENSIONS IN MILLIMETRES (INCHES)

DSLHG-06-4W-*-13/1390

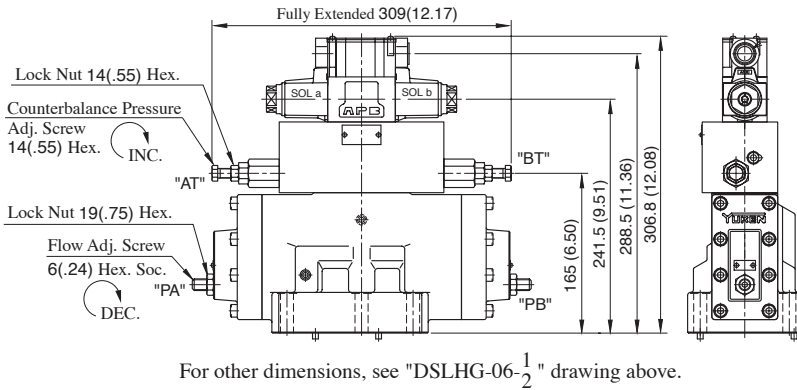

For other dimensions, see "DSLHG-06- $\frac{1}{2}$ " drawing above.

DSLHG-06-4A-*-13/1390

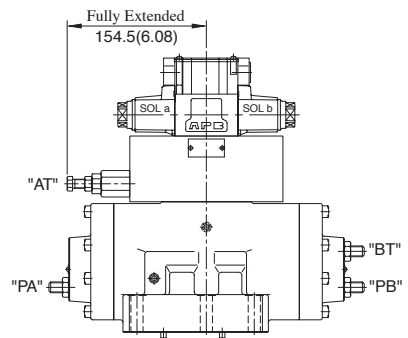

For other dimensions, see "DSLHG-06-4W" drawing left.

DSLHG-06-5W-*-13/1390

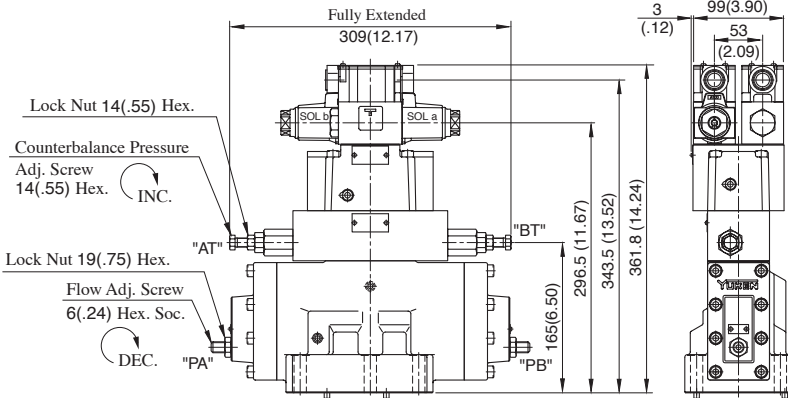

For other dimensions, see "DSLHG-06- $\frac{1}{2}$ " drawing above.

DSLHG-06-5A-*-13/1390

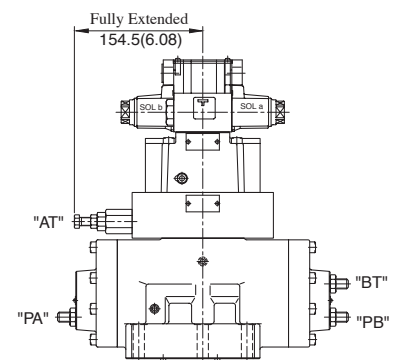

For other dimensions, see "DSLHG-06-5W" drawing left.

DSLHG-06- $\frac{1}{2}$ -*-N-13/1390

Plug-in Connector Type

Mounting Surface:
ISO4401-AE-08-4-A

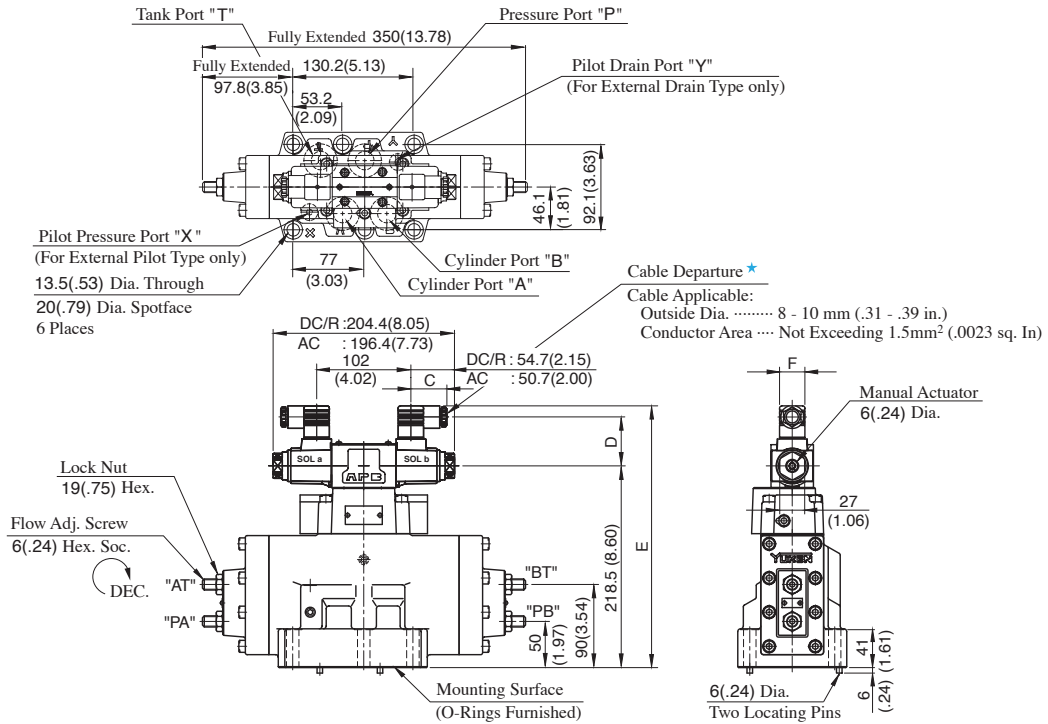

Model Numbers	Dimensions mm (Inches)			
	C	D	E	F
DSLHG-06-*-A*-N	39 (1.54)	53 (2.09)	283.5 (11.16)	27.5 (1.08)
DSLHG-06-*-D*-N	39 (1.54)	64 (2.52)	294.5 (11.59)	27.5 (1.08)
DSLHG-06-*-R*-N	53 (2.09)	57.2 (2.25)	297.5 (11.71)	34 (1.34)

★ Position of cable departure can be changed. For the details, refer to DSLHG-04 valve on page 466.

DSLHG-06-3-*-N-13/1390

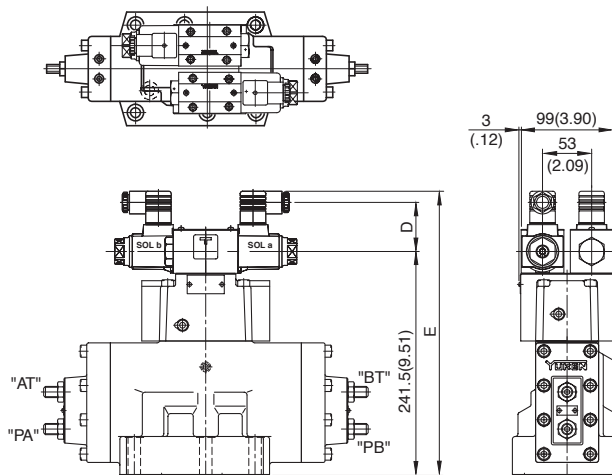

Model Numbers	Dimensions mm (Inches)	
	D	E
DSLHG-06-3-A*-N	53 (2.09)	306.5 (12.07)
DSLHG-06-3-D*-N	64 (2.52)	317.5 (12.50)
DSLHG-06-3-R*-N	57.2 (2.25)	320.5 (12.62)

DIMENSIONS IN
MILLIMETRES (INCHES)

For other dimensions, see "DSLHG-06- $\frac{1}{2}$ -*-N" drawing above.

Plug-in Connector Type

Mounting Surface:
ISO4401-AE-08-4-A

DSLHG-06-4W-* -N-13/1390

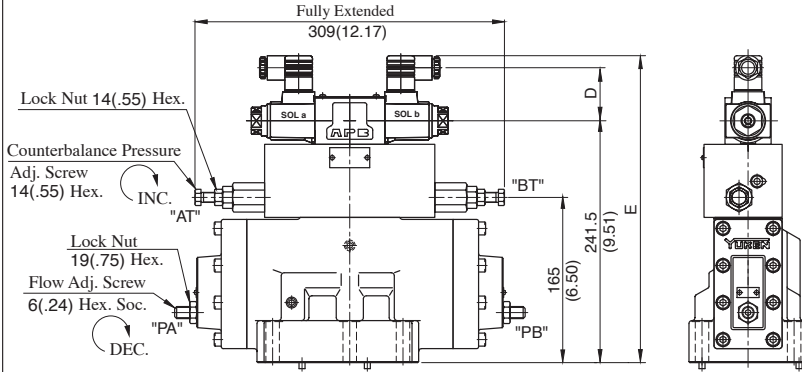

Model Numbers	Dimensions mm (Inches)	
	D	E
DSLHG-06-4W-A*-N	53 (2.09)	306.5 (12.07)
DSLHG-06-4W-D*-N	64 (2.52)	317.5 (12.50)
DSLHG-06-4W-R*-N	57.2 (2.25)	320.5 (12.62)

For other dimensions, see DSLHG-06- $\frac{1}{2}$ -*-N on the [previous page](#).

DSLHG-06-4A-* -N-13/1390

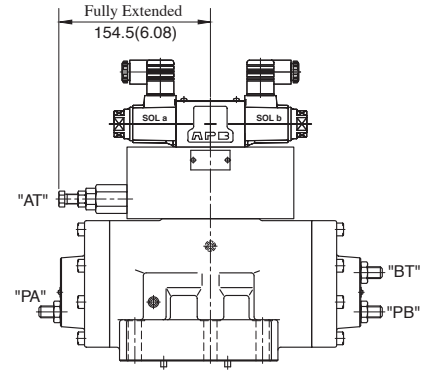

For other dimensions, see "DSLHG-06-4W-* -N" drawing left.

DSLHG-06-5W-* -N-13/1390

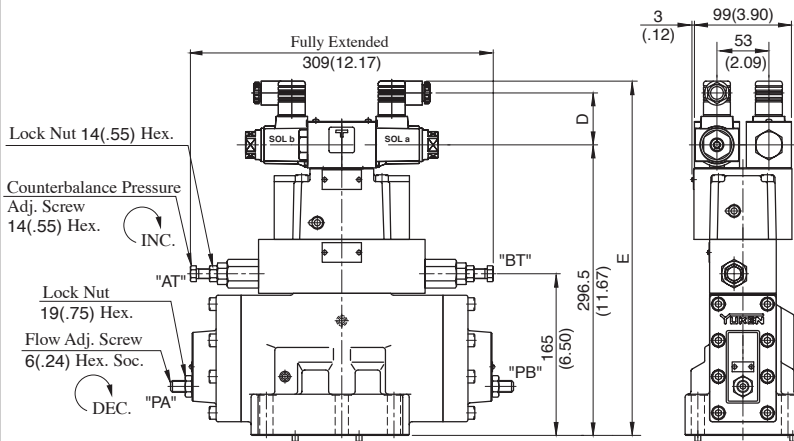

Model Numbers	Dimensions mm (Inches)	
	D	E
DSLHG-06-5W-A*-N	53 (2.09)	361.5 (14.23)
DSLHG-06-5W-D*-N	64 (2.52)	372.5 (14.67)
DSLHG-06-5W-R*-N	57.2 (2.25)	375.5 (14.78)

For other dimensions, see DSLHG-06- $\frac{1}{2}$ -*-N on the [previous page](#).

DSLHG-06-5A-* -N-13/1390

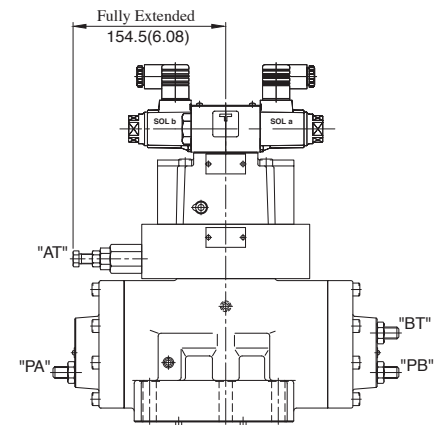

For other dimensions, see "DSLHG-06-5W-* -N" drawing left.

**DIMENSIONS IN
MILLIMETRES (INCHES)**

Terminal Box Type

Mounting Surface:
ISO 4401-AF-10-4-A

DSLHG-10- $\frac{1}{2}$ -*-13/1390

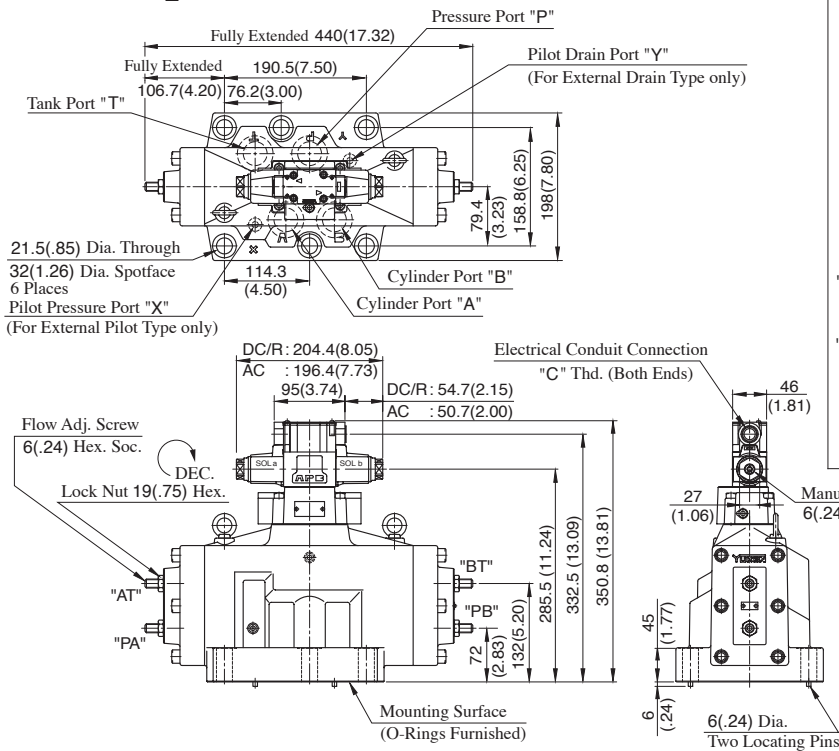

DSLHG-10-3-*-13/1390

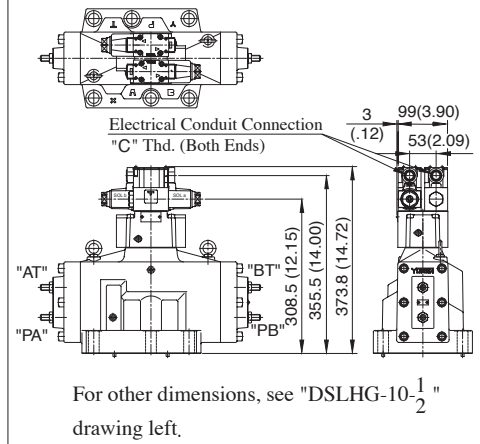

Model Numbers	"C" Thd.
DSLHG-10-*-13	G 1/2
DSLHG-10-*-1390	1/2 NPT

DIMENSIONS IN
MILLIMETRES (INCHES)

DSLHG-10-4W-*-13/1390

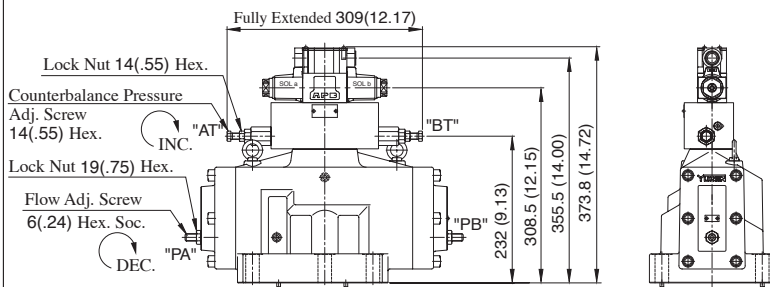

For other dimensions, see "DSLHG-10- $\frac{1}{2}$ " drawing above.

DSLHG-10-4A-*-13/1390

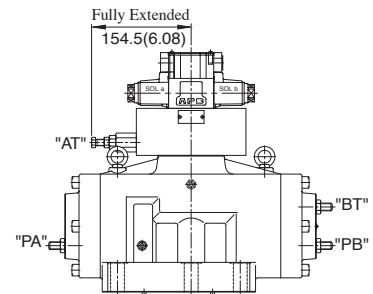

For other dimensions, see "DSLHG-10-4W"
drawing left.

DSLHG-10-5W-*-13/1390

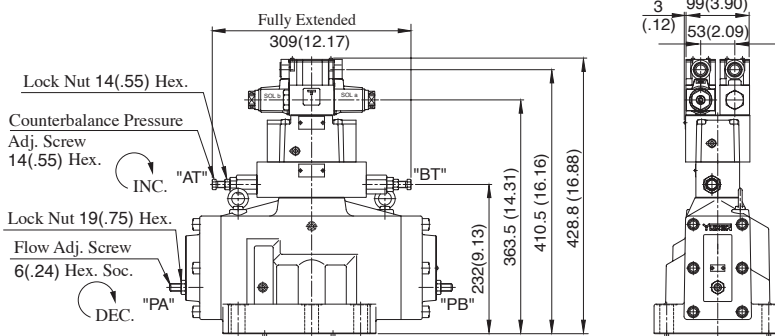

For other dimensions, see "DSLHG-10- $\frac{1}{2}$ " drawing above.

DSLHG-10-5A-*-13/1390

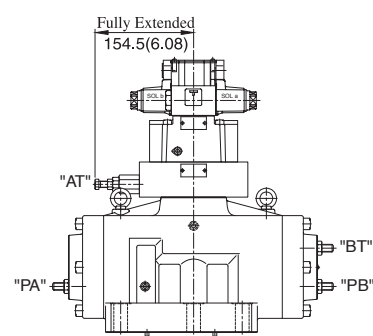

For other dimensions, see "DSLHG-10-5W"
drawing left.

Plug-in Connector Type

Mounting Surface:
ISO 4401-AF-10-4-A

DSLHG-10- $\frac{1}{2}$ -*-N-13/1390

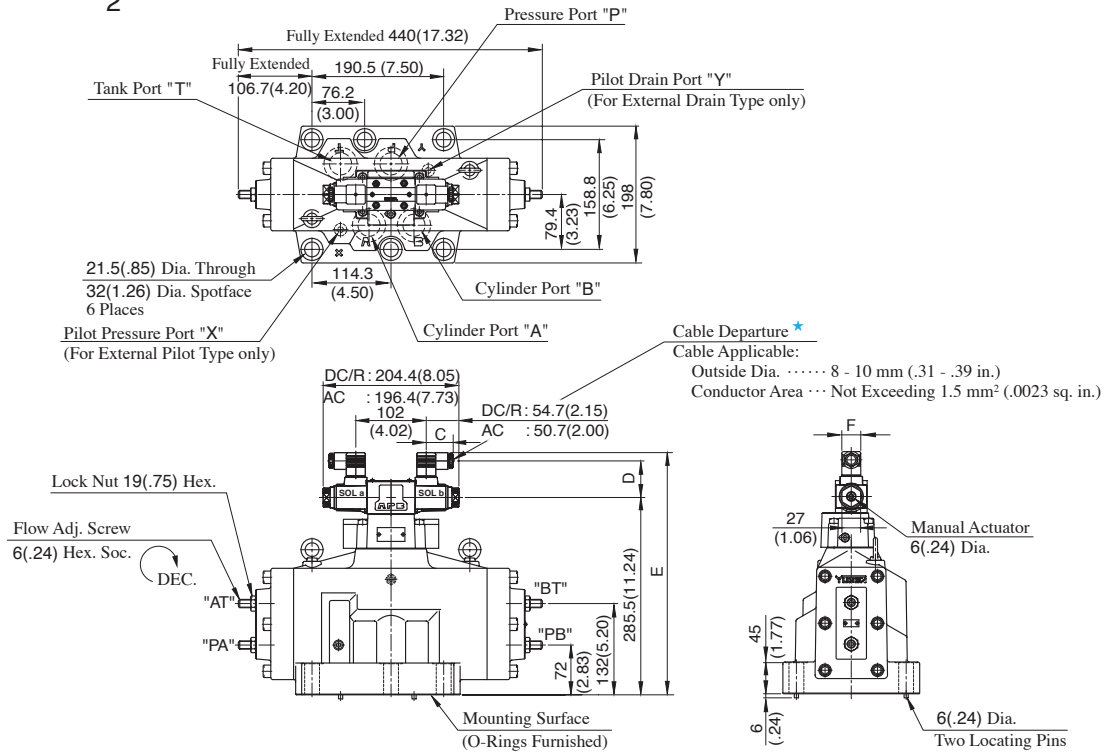

Model Numbers	Dimensions mm (Inches)			
	C	D	E	F
DSLHG-10-*-A*-N	39 (1.54)	53 (2.09)	350.5 (13.80)	27.5 (1.08)
DSLHG-10-*-D*-N	39 (1.54)	64 (2.52)	361.5 (14.23)	27.5 (1.08)
DSLHG-10-*-R*-N	53 (2.09)	57.2(2.25)	364.5 (14.35)	34 (1.34)

★ Position of cable departure can be changed. For the details, refer to DSLHG-04 valve on page 466.

DSLHG-10-3-*-N-13/1390

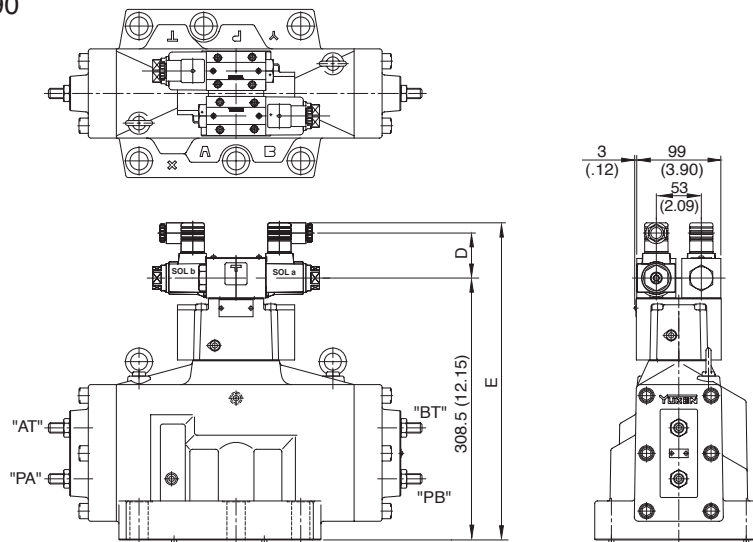

Model Numbers	Dimensions mm (Inches)	
	D	E
DSLHG-10-3-A*-N	53 (2.09)	373.5 (14.70)
DSLHG-10-3-D*-N	64 (2.52)	384.5 (15.14)
DSLHG-10-3-R*-N	57.2 (2.25)	387.5 (15.26)

**DIMENSIONS IN
MILLIMETRES (INCHES)**

For other dimensions, see "DSLHG-10- $\frac{1}{2}$ -*-N" drawing above.

Plug-in Connector Type

Mounting Surface:
ISO 4401-AF-10-4-A

DSLHG-10-4W-*-N-13/1390

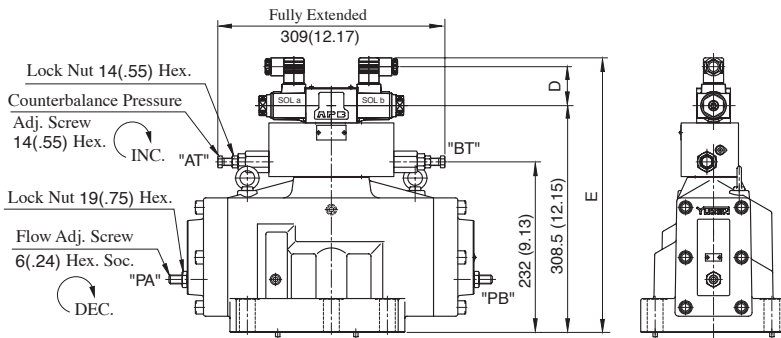

Model Numbers	Dimensions mm (Inches)	
	D	E
DSLHG-10-4W-A*-N	53 (2.09)	373.5 (14.70)
DSLHG-10-4W-D*-N	64 (2.52)	384.5 (15.14)
DSLHG-10-4W-R*-N	57.2 (2.25)	387.5 (15.26)

For other dimensions, see DSLHG-10- $\frac{1}{2}$ -*-N on the [previous page](#).

DSLHG-10-4A-*-N-13/1390

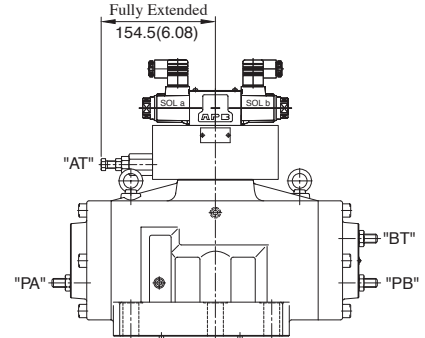

For other dimensions, see
"DSLHG-10-4W-*-N" drawing left.

DSLHG-10-5W-*-N-13/1390

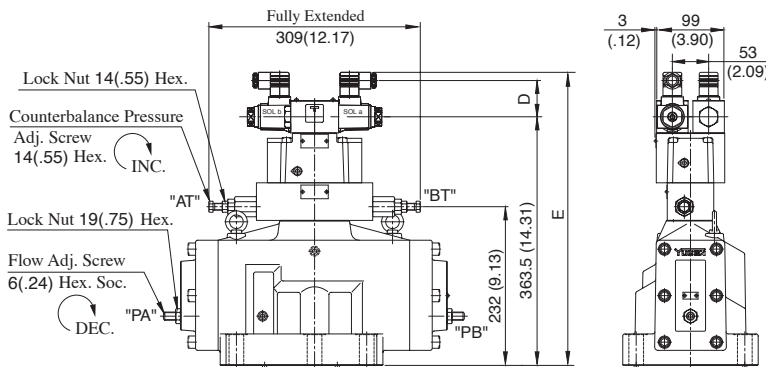

Model Numbers	Dimensions mm (Inches)	
	D	E
DSLHG-10-5W-A*-N	53 (2.09)	428.5 (16.87)
DSLHG-10-5W-D*-N	64 (2.52)	439.5 (17.30)
DSLHG-10-5W-R*-N	57.2 (2.25)	442.5 (17.42)

For other dimensions, see DSLHG-10- $\frac{1}{2}$ -*-N on the [previous page](#).

DSLHG-10-5A- *-N-13/1390

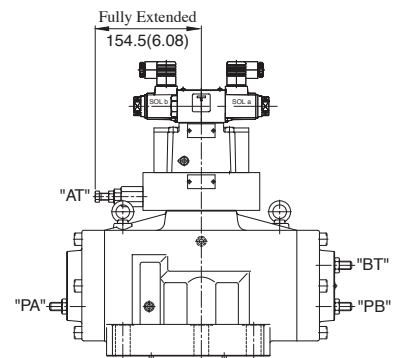

For other dimensions, see
"DSLHG-10-5W-*-N" drawing left.

**DIMENSIONS IN
MILLIMETRES (INCHES)**

E

Multi Purpose Control Valves

■ List of Seals for Main Valve, Pilot Selector Valve and Orifice

DSLHG-04/06/10- $\frac{1}{2}$ -*-13/1390

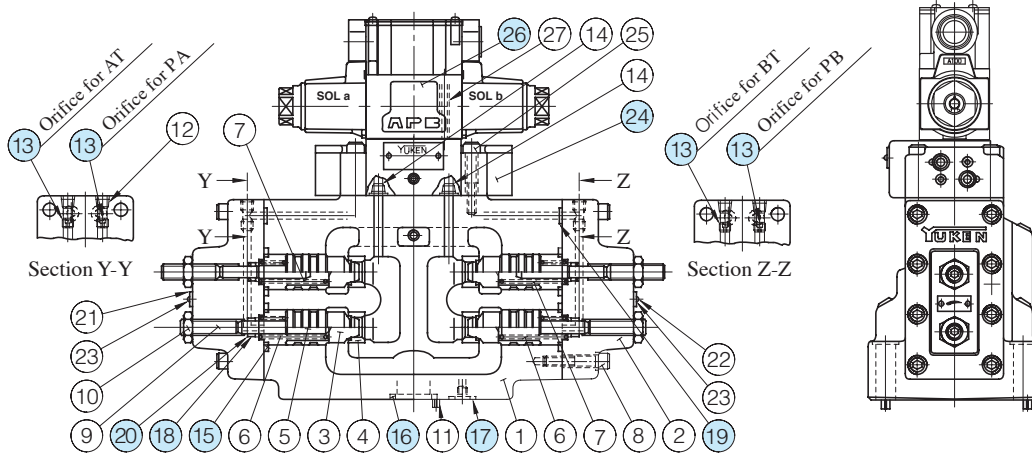

DSLHG-04/06/10-3-*-13/1390

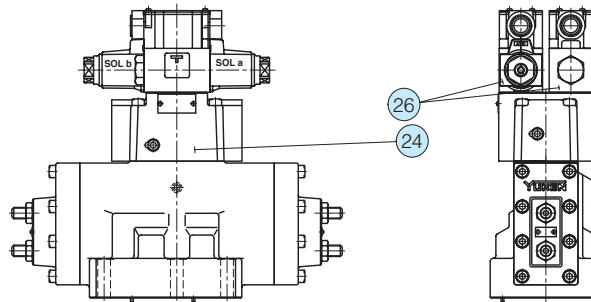

Note) Main valve is same as above drawings.

● List of Seals for Main Valves

Item	Name of Parts	Part Numbers			Qty.
		DSLHG-04	DSLHG-06	DSLHG-10	
15	O-Ring	SO-NB-P22	SO-NB-G30	SO-NB-G40	4
16	O-Ring	SO-NB-P22	SO-NB-P30	SO-NB-P42	4
17	O-Ring	SO-NB-P9	SO-NB-P14	SO-NB-P14	2
18	O-Ring	SO-NA-P8	SO-NA-P10	SO-NA-P16	4
19	O-Ring	SO-NB-P8	SO-NB-P9	SO-NB-P11	4
20	Back Up Ring	SO-BB-P8	SO-BB-P10	SO-BB-P16	4

Note: When ordering the seals, please specify the seal kit number listed on page 478.

● Item 13 Orifice

The timing of flow path opening/closing can be adjusted as required by selecting the appropriate pilot orifice diameter. When the diameter of the orifice is to be changed, another orifice should be ordered. Standard built-in orifice diameters and selectable orifice diameters are listed in the table below.

Orifice Type	TP-OPT-1/16 x d			Max. Dia. at Pressure over 20 MPa(2900 PSI)
	Orifice Diameter "d" mm			
	Standard Built-in	Selectable		
DSLHG-04	1.0	0.5, 0.6, 0.8, 1.0	1.2	
DSLHG-06	1.2	1.2, 1.4, 1.6, 1.8		
DSLHG-10	1.4	2.0, 2.5	1.4	

● Item 24 Pilot Selector Valve List

Multi-Purpose Control Valve Model Numbers	24 Pilot Selector Valve Model Numbers
DSLHG-04-1	CG-04-1-10
DSLHG-04-2	CG-04-2-10
DSLHG-04-3	CG-04-3-10
DSLHG-06-1	CG-06-1-10
DSLHG-06-2	CG-06-2-10
DSLHG-06-3	CG-06-3-10
DSLHG-10-1	CG-06-1-10
DSLHG-10-2	CG-06-2-10
DSLHG-10-3	CG-06-3-10

Note: For details of Pilot Selector Valve, see page 476.

● Pilot Valve

Refer to page 478 for Pilot Valve Model Numbers.

List of Seals for Main Valves and Pilot Selector Valve

DSLHG-04/06/10-4W-*-12/1290

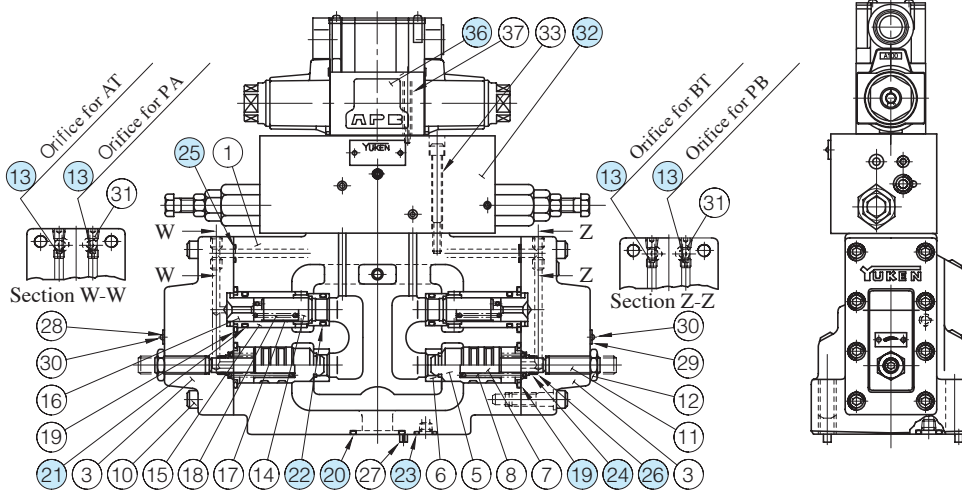

DSLHG-04/06/10-4A
5A-*-12/1290

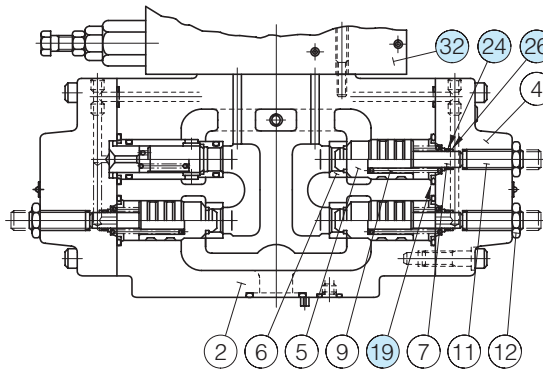

DSLHG-04/06/10-5W-*-12/1290

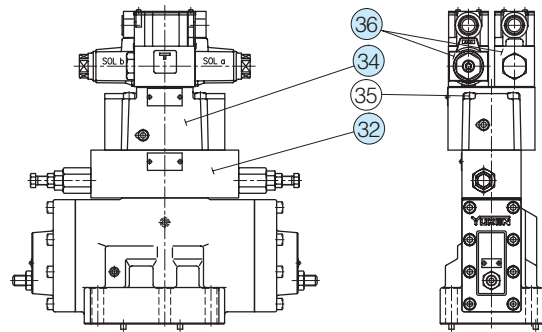

Note) Main valve is the same as above drawings.

List of Seals for Main Valves

Item	Name of Parts	Part Numbers			Qty.
		DSLHG-04	DSLHG-06	DSLHG-10	
19	O-Ring	SO-NB-P22	SO-NB-G30	SO-NB-G40	4
20	O-Ring	SO-NB-P22	SO-NB-P30	SO-NB-P42	4
21	O-Ring	SO-NB-P16	SO-NB-P22	SO-NB-P30	2(1)
22	O-Ring	SO-NB-P14	SO-NB-P20	SO-NB-A122	2(1)
23	O-Ring	SO-NB-P9	SO-NB-P14	SO-NB-P14	2
24	O-Ring	SO-NA-P8	SO-NA-P10	SO-NA-P16	2(3)
25	O-Ring	SO-NB-P8	SO-NB-P9	SO-NB-P11	4
26	Back Up Ring	SO-BB-P8	SO-BB-P10	SO-BB-P16	2(3)

Note 1: The figures in () indicate the quantity of seals used for 4A and 5A.

Note 2: When ordering the seals, please specify the seal kit number listed on page 478.

Pilot Valve

Refer to page 478 for Pilot Valve Model Numbers.

Pilot Selector Valve List

Multi-Purpose Control Valve Model Numbers	Pilot Selector Valve Model Numbers	
	Item (32)	Item (34)
DSLHG-04-4A-■	CG-04-4A-■-10	—
DSLHG-04-4W-■	CG-04-4W-■-10	—
DSLHG-04-5A-■	CG-04-5A-■-10	CG-04-3-10
DSLHG-04-5W-■	CG-04-5W-■-10	
DSLHG-06-4A	CG-06-4A-10	—
DSLHG-06-4W	CG-06-4W-10	—
DSLHG-06-5A	CG-06-5A-10	CG-06-3-10
DSLHG-06-5W	CG-06-5W-10	
DSLHG-10-4A	CG-06-4A-10	—
DSLHG-10-4W	CG-06-4W-10	—
DSLHG-10-5A	CG-06-5A-10	CG-06-3-10
DSLHG-10-5W	CG-06-5W-10	

Note: Fill "B" or "H" representing the pressure adjustment range in section marked with ■.

See page 477 for the details of the pilot selector valves.

● See the previous page for Item (13) Orifice.

■ List of Seals (Pilot Selector Valves)

CG-04/06-1-10

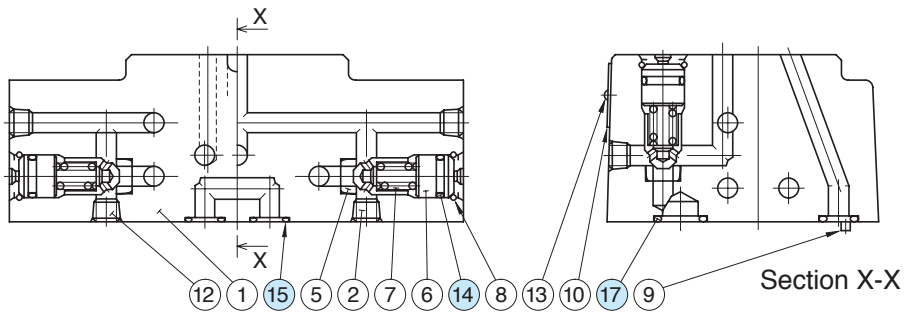

CG-04/06-2-10

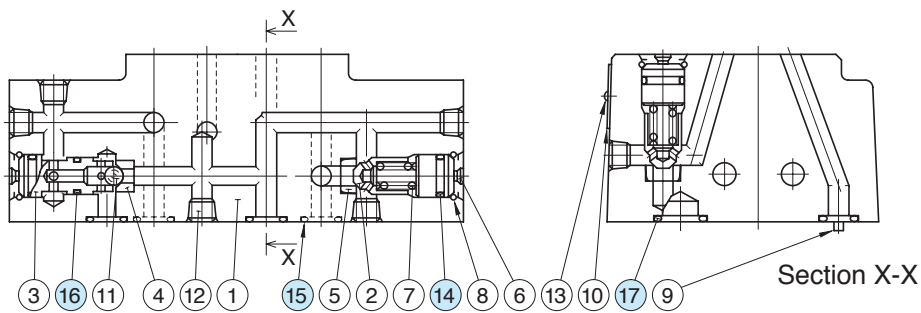

CG-04/06-3-10

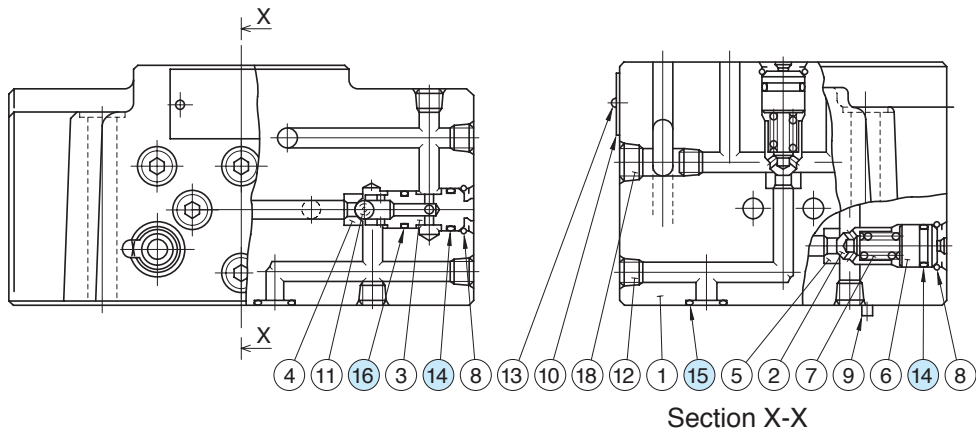

● List of Seals

Item	Name of Parts	CG-04					CG-06			
		Part Numbers	Quantity			Part Numbers	Quantity			
			CG-04-1	CG-04-2	CG-04-3		CG-06-1	CG-06-2	CG-06-3	
14	O-Ring	SO-NB-P10	3	5	5	SO-NB-P10	3	5	5	
15	O-Ring	SO-NB-P8	7	7	8	SO-NB-P9	7	7	8	
16	O-Ring	SO-NB-P8	—	2	2	SO-NB-P8	—	2	2	
17	O-Ring	SO-NB-P8	1	1	—	SO-NB-A014	1	1	—	

Note: When ordering the o-rings, please specify the seal kit number listed in [page 478](#).

List of Seals (Pilot Selector Valves)

CG-04/06-4W-10

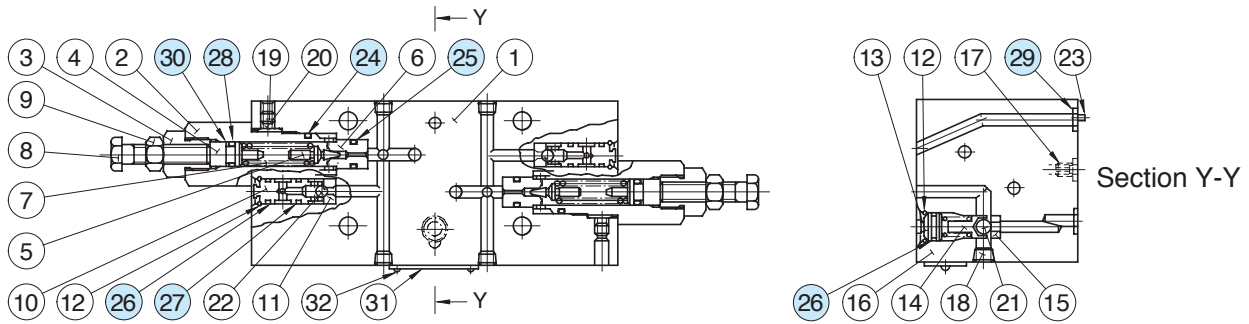

CG-04/06-4A-10

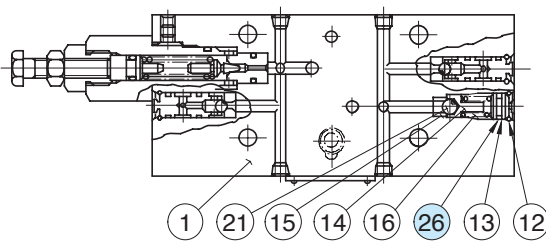

CG-04/06-5A-10

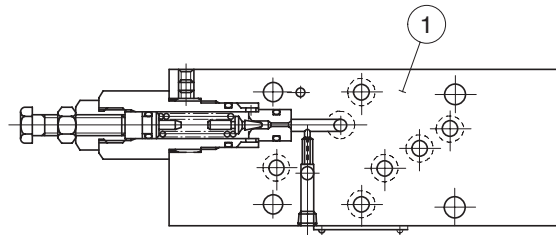

CG-04/06-5W-10

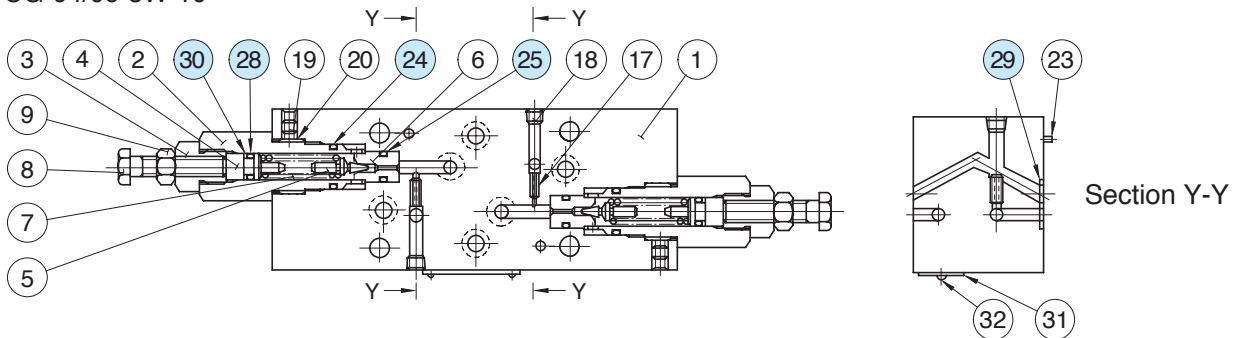

List of Seals

Item	Name of Parts	CG-04				CG-06					
		Part Numbers	Quantity				Part Numbers	Quantity			
			-4W-	-4A-	-5W-	-5A-		-4W-	-4A-	-5W-	-5A-
24	O-Ring	SO-NB-P12	2	1	2	1	SO-NB-P16	2	1	2	1
25	O-Ring	SO-NB-P9	2	1	2	1	SO-NB-P11	2	1	2	1
26	O-Ring	SO-NB-P10	3	4	—	—	SO-NB-P10	3	4	—	—
27	O-Ring	SO-NB-P8	2	2	—	—	SO-NB-P8	2	2	—	—
28	O-Ring	SO-NA-P6	2	1	2	1	SO-NA-P9	2	1	2	1
29	O-Ring	SO-NB-P8	8	8	8	8	SO-NB-P9	8	8	8	8
30	Back Up Ring	SO-BB-P6	2	1	2	1	SO-BB-P9	2	1	2	1

Note: When ordering the seals, please specify the seal kit number listed in [page 478](#).

List of Seal Kits and Pilot Valves

Model Numbers	Pilot Valve Model Numbers	Seal Kit Numbers		
		Complete Kit	For Pilot Selector Valves	For Pilot Valves
DSLHG-04-1-★-▲-13 DSLHG-04-1-★-▲-1390	DSG-01-3C9-★-▲-70 DSG-01-3C9-★-▲-7090	KS-DSLHG-04-1-▲-13	KS-CG-04-1-10	KS-DSG-01-▲-70 (1 Set Req'd)
DSLHG-04-2-★-▲-13 DSLHG-04-2-★-▲-1390	DSG-01-3C9-★-▲-70 DSG-01-3C9-★-▲-7090	KS-DSLHG-04-2-▲-13	KS-CG-04-2-10	
DSLHG-04-3-★-▲-13 DSLHG-04-3-★-▲-1390	DSG-01-2B2-★-▲-70 DSG-01-2B2-★-▲-7090	KS-DSLHG-04-3-▲-13		KS-DSG-01-▲-70 (2 Set Req'd)
DSLHG-04-4A-★-▲-13 DSLHG-04-4A-★-▲-1390	DSG-01-3C9-★-▲-70 DSG-01-3C9-★-▲-7090	KS-DSLHG-04-4A-▲-13	KS-CG-04-4A-10	KS-DSG-01-▲-70 (1 Set Req'd)
DSLHG-04-4W-★-▲-13 DSLHG-04-4W-★-▲-1390	DSG-01-3C9-★-▲-70 DSG-01-3C9-★-▲-7090	KS-DSLHG-04-4W-▲-13	KS-CG-04-4W-10	
DSLHG-04-5A-★-▲-13 DSLHG-04-5A-★-▲-1390	DSG-01-2B2-★-▲-70 DSG-01-2B2-★-▲-7090	KS-DSLHG-04-5A-▲-13	KS-CG-04-5A-10	KS-DSG-01-▲-70 (2 Set Req'd)
DSLHG-04-5W-★-▲-13 DSLHG-04-5W-★-▲-1390	DSG-01-2B2-★-▲-70 DSG-01-2B2-★-▲-7090	KS-DSLHG-04-5W-▲-13	KS-CG-04-5W-10	
DSLHG-06-1-★-▲-13 DSLHG-06-1-★-▲-1390	DSG-01-3C9-★-▲-70 DSG-01-3C9-★-▲-7090	KS-DSLHG-06-1-▲-13	KS-CG-06-1-10	KS-DSG-01-▲-70 (1 Set Req'd)
DSLHG-06-2-★-▲-13 DSLHG-06-2-★-▲-1390	DSG-01-3C9-★-▲-70 DSG-01-3C9-★-▲-7090	KS-DSLHG-06-2-▲-13	KS-CG-06-2-10	
DSLHG-06-3-★-▲-13 DSLHG-06-3-★-▲-1390	DSG-01-2B2-★-▲-70 DSG-01-2B2-★-▲-7090	KS-DSLHG-06-3-▲-13	KS-CG-06-3-10	KS-DSG-01-▲-70 (2 Set Req'd)
DSLHG-06-4A-★-▲-13 DSLHG-06-4A-★-▲-1390	DSG-01-3C9-★-▲-70 DSG-01-3C9-★-▲-7090	KS-DSLHG-06-4A-▲-13	KS-CG-06-4A-10	KS-DSG-01-▲-70 (1 Set Req'd)
DSLHG-06-4W-★-▲-13 DSLHG-06-4W-★-▲-1390	DSG-01-3C9-★-▲-70 DSG-01-3C9-★-▲-7090	KS-DSLHG-06-4W-▲-13	KS-CG-06-4W-10	
DSLHG-06-5A-★-▲-13 DSLHG-06-5A-★-▲-1390	DSG-01-2B2-★-▲-70 DSG-01-2B2-★-▲-7090	KS-DSLHG-06-5A-▲-13	KS-CG-06-5A-10	KS-DSG-01-▲-70 (2 Set Req'd)
DSLHG-06-5W-★-▲-13 DSLHG-06-5W-★-▲-1390	DSG-01-2B2-★-▲-70 DSG-01-2B2-★-▲-7090	KS-DSLHG-06-5W-▲-13	KS-CG-06-5W-10	
DSLHG-10-1-★-▲-13 DSLHG-10-1-★-▲-1390	DSG-01-3C9-★-▲-70 DSG-01-3C9-★-▲-7090	KS-DSLHG-10-1-▲-13	KS-CG-06-1-10	KS-DSG-01-▲-70 (1 Set Req'd)
DSLHG-10-2-★-▲-13 DSLHG-10-2-★-▲-1390	DSG-01-3C9-★-▲-70 DSG-01-3C9-★-▲-7090	KS-DSLHG-10-2-▲-13	KS-CG-06-2-10	
DSLHG-10-3-★-▲-13 DSLHG-10-3-★-▲-1390	DSG-01-2B2-★-▲-70 DSG-01-2B2-★-▲-7090	KS-DSLHG-10-3-▲-13	KS-CG-06-3-10	KS-DSG-01-▲-70 (2 Set Req'd)
DSLHG-10-4A-★-▲-13 DSLHG-10-4A-★-▲-1390	DSG-01-3C9-★-▲-70 DSG-01-3C9-★-▲-7090	KS-DSLHG-10-4A-▲-13	KS-CG-06-4A-10	KS-DSG-01-▲-70 (1 Set Req'd)
DSLHG-10-4W-★-▲-13 DSLHG-10-4W-★-▲-1390	DSG-01-3C9-★-▲-70 DSG-01-3C9-★-▲-7090	KS-DSLHG-10-4W-▲-13	KS-CG-06-4W-10	
DSLHG-10-5A-★-▲-13 DSLHG-10-5A-★-▲-1390	DSG-01-2B2-★-▲-70 DSG-01-2B2-★-▲-7090	KS-DSLHG-10-5A-▲-13	KS-CG-06-5A-10	KS-DSG-01-▲-70 (2 Set Req'd)
DSLHG-10-5W-★-▲-13 DSLHG-10-5W-★-▲-1390	DSG-01-2B2-★-▲-70 DSG-01-2B2-★-▲-7090	KS-DSLHG-10-5W-▲-13	KS-CG-06-5W-10	

Note 1: Fill coil type (a symbol representing current/voltage) in section marked ★. Likewise, in section marked ▲, fill a symbol representing the type of electrical conduit connection (None: Terminal Box Type, N: Plug-in Connector Type).

2: A complete seal kit is composed of seal kit for pilot selector valve, seal kit for pilot valve and seal for main valve.

See pages 474 and 475 for information on the seals for main valve.

3: See page 344 for the detailed information on the pilot valves.

How to Change Pilot & Drain Connection

Pilot Connection and Drain Connection can be changed easily with a disconnection/connection of pilot plug. The following drawings give illustrations of External Pilot-External Drain Type, When changing to Internal Pilot-Internal Drain Type, the following procedure may be followed.

External Pilot → Internal Pilot (See Section E-E)

- 1) Remove pipe plug ①.
- 2) Remove pipe plug ②.
- 3) Wind a sealing tape around the pipe plug ①, then fit the plug into the port.

External Drain → Internal Drain (See Section D-D)

- 1) Remove pipe plug ③.
- 2) Remove pipe plug ④.
- 3) Wind a sealing tape around the pipe plug ③, then fit the plug into the port.
- 4) In case of DSLHG-04, fit the plug into the port "Y" on the sub-plate. In case of DSLHG-06/10, wind a sealing tape around the plug ④ and then thread it into the port "Y".

DSLHG-04

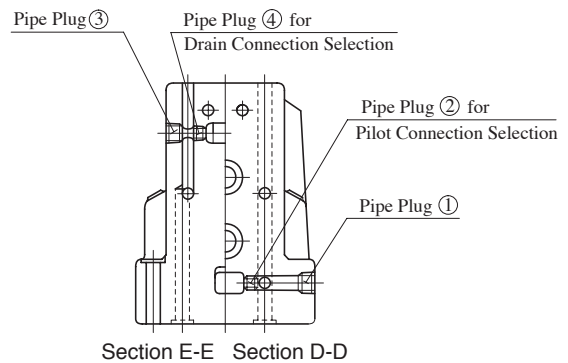
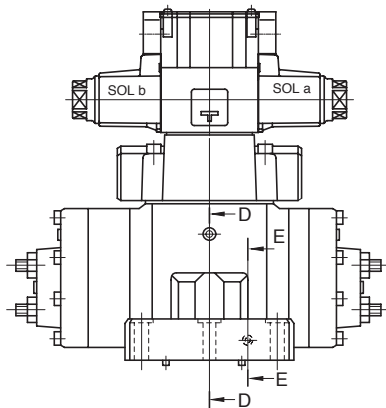

DSLHG-06/10

