

VARIABLE DISPLACEMENT PISTON PUMPS
HSP SERIES
VERSION 3 I

Single Piston Pumps
Thru-Drive Piston Pumps



Pumps and spare parts are interchangeable to **Rexroth** A10VSO design

HYDRAULIC PUMP

HSP-10VO

TYPE CODE FOR STANDARD PROGRAM

HSP-10V	O	45	DFLR /	31	R	-	V	P	A	12	N00	24DC(HO)
1	2	3	4	5	6	7	8	9	10	11	12	13

Version

1	Standard version (without symbol)	18	28	45	71	100	140
---	-----------------------------------	----	----	----	----	-----	-----

Axial piston unit

2	Swashplate design, variable, nominal pressure 4000 psi(280 bar), maximum pressure 5100 psi(350 bar)	HSP-10V
---	---	---------

Operation mode

3	Pump, open circuit	O
---	--------------------	---

Size (NG)

4	Geometric displacement, see table of values on pages 6 and 7	18	28	45	71	100	140
---	--	----	----	----	----	-----	-----

Control device

5	Pressure control	■	■	■	■	■	■	DR	※
	Pressure remote control	■	■	■	■	■	■	DRG	
	with flow control, hydraulic								
	X-T open	■	■	■	■	■	■	DFR	※
	X-T closed	■	■	■	■	■	■	DFR1	※
	with pressure electrical on-off								
	N.O	■	■	■	■	■	■	HO ¹⁾	
	N.C	■	■	■	■	■	■	HC ¹⁾	
	with proportional pressure control	■	■	■	■	■	■	ERHZ12	
			■	■	■	■	■	ERHZ24	
Pressure, flow and power control	-	■	■	■	■	■	DFLR	※	

Direction of rotation

7	Viewed on drive shaft	clockwise 	R
		counter clockwise L 	L

Seals

8	FKM (VITON)	V
	NBR	P

1)The following must be taken into account during project planning:

Excessive current levels (I >1200 mA with 12 V or I > 600 mA with 24 V) to the **ERHZ** solenoid can result in undesired increase of pressure which can lead to pump or system damage:

- Use I_{max} current limiter solenoids.

- A sandwich plate pressure reducing valve can be used to protect the pump in the event of overflow.

An accessory kit with pressure reducing sandwich plate can be ordered

■ = available - = on request ※ = standard type

¹⁾ To complete with mechanical compensator code (es. DFRHO, DFR1HO, DRGHO)

HYDRAULIC PUMP

HSP-10VO

TYPE CODE FOR STANDARD PROGRAM

1	HSP-10V	3	O	4	45	5	DFLR /	6	31	7	R	-	8	V	9	P	10	A	11	12	12	N00	13	24DC(HO)
---	---------	---	---	---	----	---	--------	---	----	---	---	---	---	---	---	---	----	---	----	----	----	-----	----	----------

Version

		18	28	45	71	100	140		
9	Splined shaft ANSI B92.1a	standard shaft	■	■	■	■	■	S	
		similar to shaft "S" however for higher input torque	■	■	■	■	-	-	R
		reduced diameter, not for through drive	■	-	-	-	■	-	U
	Parallel keyed shaft Not for through drive	Metric DIN 6885	■	■	■	■	■	■	P
		SAE ISO 3019-1	■	■	■	■	■	■	K
		-	-	-	-	-	-	W	

Note: Same splined shaft for SAE/Metric

Mounting flange 18 28

		18	28	45	71	100	140		
10	ISO 3019-2 (Metric)	2-hole	■	■	■	■	■	-	A
		4-hole	-	-	-	-	-	■	B
	ISO 3019-1 (SAE)	2-hole	■	■	■	■	■	-	C ³⁾
		4-hole	-	-	-	-	-	■	D ³⁾

Service line port

		18	28	45	71	100	140	
11	SAE flange ports on opposite side,metric-fastening thread	■	■	■	■	■	■	12/(42)
	SAE flange ports on opposite side,UNC fastening thread	■	■	■	■	■	■	62 ¹⁾ /(92 ¹⁾)
	Rear ports, metric mounting screws		■	■	■	-	-	11
	Rear ports, UNC mounting screws		■	■	■	■	-	61

Through drive

		18	28	45	71	100	140		
without through drive		■	■	■	■	■	■	N00	
12	Flange ISO 3019-1 Diameter	coupling for splined shaft ¹⁾ diameter							
	82-2 (A)	5/8 in	9T	16/32DP	■	■	■	■	K01
		3/4 in	11T	16/32DP	■	■	■	■	K52
	101-2 (B)	7/8 in	13T	16/32DP	-	■	■	■	K68
		1 in	15T	16/32DP	-	-	■	■	K04
	127-2 (C)	1 1/4 in	14T	12/24DP	-	-	-	■	K07
		1 1/2 in	17T	12/24DP	-	-	-	■	K24
	Ø 63 , Metric 4 hole	key shaft	Ø 25	-	■	■	■	■	K57
	Flange ISO 3019-2 Diameter								
	80 , 2-hole	3/4 in	11T	16/32DP	■	■	■	■	KB2
	100 , 2-hole	7/8 in	13T	16/32DP	-	■	■	■	KB3
		1 in	15T	16/32DP	-	-	■	■	KB4
125 , 2-hole	1 1/4 in	14T	12/24DP	-	-	-	■	KB5	
	1 1/2 in	17T	12/24DP	-	-	-	■	KB6	
180 , 4-hole	1 3/4 in	13T	8/16DP	-	-	-	■	KB7	

※

Connectors

13	Voltage	■	■	■	■	■	■	24DC
		■	■	■	■	■	■	12DC
		■	■	■	■	■	■	110AC
		■	■	■	■	■	■	230AC
		■	■	■	■	■	■	other Ve/O

HYDRAULIC PUMP

HSP-10VO

TECHNICAL DATA

Hydraulic fluid

When using environmentally acceptable hydraulic fluids, the limitations regarding technical data and seals must be observed. Please contact us. When ordering, indicate the hydraulic fluid that is to be used.

Operating viscosity range

For optimum efficiency and service life we recommend that the operating viscosity (at operating temperature) be selected in the range.

$$V_{opt} = \text{opt. operating viscosity } 80 - 170 \text{ SUS (16 ... 36 mm}^2\text{/s)}$$

referred to reservoir temperature (open circuit).

Limits of viscosity range

For critical operating conditions the following values apply:

$$n_{min} = 60 \text{ SUS (10 mm}^2\text{/s)}$$

short-term ($t \leq 1 \text{ min}$)

at max perm. case drain temp. of 195°F (90 °C).

Please also ensure that the max. case drain temperature of 195 °F (90 °C) is not exceeded in localized areas (for instance, in the bearing area). The fluid temperature in the bearing area is approx. 7 °F (5 K) higher than the average case drain temperature

$$n_{max} = 4640 \text{ SUS (1000 mm}^2\text{/s)}$$

short-term ($t \leq 1 \text{ min}$)

on cold start

($p \leq 435 \text{ psi (30 bar), } n \leq 1000 \text{ rpm, } t_{min} = -13^\circ\text{F (-25 } ^\circ\text{C)}$).

Depending on the installation situation, special measures are necessary at temperatures between -40 °C and -25 °C). Please contact us.

Selection diagram

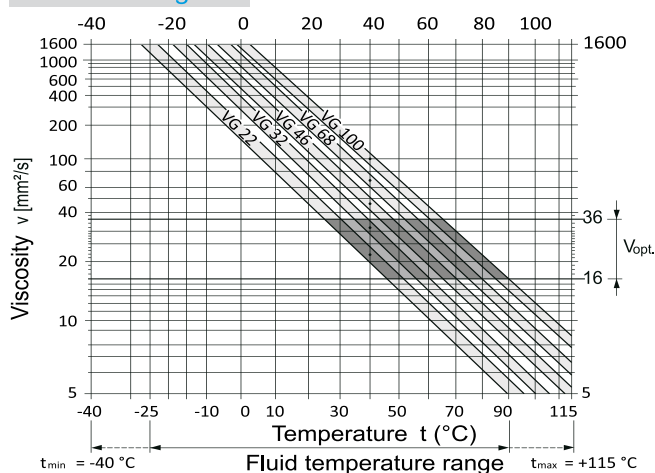

Notes on the choice of hydraulic fluid

In order to select the correct hydraulic fluid, it is necessary to know the operating temperature in the reservoir (open circuit) in relation to the ambient temperature.

The hydraulic fluid should be selected so that within the operating temperature range, the viscosity lies within the optimum range (v_{opt}), see shaded section of the selection diagram. We recommend to select the higher viscosity grade in each case.

Example: at an ambient temperature of X °F (°C) the operating temperature is 140 °F (60 °C). In the optimum operating viscosity range (v_{opt} ; shaded area) this corresponds to viscosity grades VG 46 resp. VG 68; VG 68 should be selected.

Filtration of the hydraulic fluid

The finer the filtration the better the cleanliness level of the hydraulic fluid and the longer the service life of the axial piston unit. In order to guarantee the functional reliability of the axial piston unit it is necessary to carry out a gravimetric evaluation of the hydraulic fluid to determine the particle contamination and the cleanliness level according to ISO 4406. A cleanliness level of at least 20/18/15 must be maintained. At very high hydraulic fluid temperatures (195 °F (90 °C) to maximum 239 °F (115 °C)), a cleanliness level of at least 19/17/14 according to ISO 4406 is necessary. If the above cleanliness levels cannot be maintained, please contact us.

Important

The case drain temperature is influenced by pressure and input speed and is always higher than the reservoir temperature. However, at no point in the component may the temperature exceed 195 °F (90 °C). The temperature difference specified on the left is to be taken into account when determining the viscosity in the bearing.

If the above conditions cannot be met, due to extreme operating parameters please contact us.

HYDRAULIC PUMP

HSP-10VO

TECHNICAL DATA

Operating pressure range

- Pressure at service line port B
- Nominal pressure p_{nom} ____ 4000 psi (280 bar) absolute
- Maximum pressure p_{max} ____ 5100 psi (350 bar) absolute
 Single operating period _____ 2.5 ms
 Total operating period _____ 300 h
- Min. pressure (high-pressure side) _ 145 psi (10 bar) absolute¹⁾
- Rate of pressure change RA_{max} _ 232060 psi (16000 bar/s)

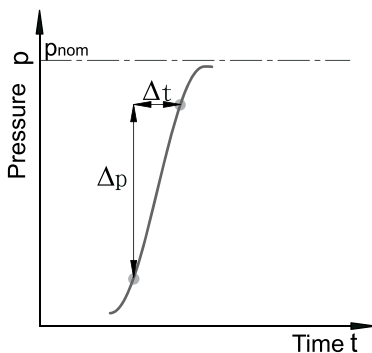

Pressure at suction port S (inlet)

Minimum pressure PS_{min} ____ 12 psi (0.8 bar) absolute
 Maximum pressure PS_{max} _ 145 psi (10 bar)¹⁾ absolute

Note

Please contact us for values for other hydraulic fluids.

Case drain pressure

Maximum permissible case drain pressure (at port L · L1) :
 Maximum 7 psi (0.5 bar) higher than the inlet pressure at port S, however not higher than 30 psi (2 bar) absolute.

$PL_{max\ abs}$ _____ 2 bar absolute¹⁾

¹⁾ Other values on request

Definition

■ Nominal pressure p_{nom}

The nominal pressure corresponds to the maximum design pressure.

■ Maximum pressure p_{max}

The maximum pressure corresponds to the maximum operating pressure within the single operating period. The total of the single operating periods must not exceed the total operating period.

■ Minimum pressure (high-pressure side)

Minimum pressure in the high-pressure side (port B) that is required in order to prevent damage to the axial piston unit. The minimum pressure depends on the speed and displacement of the axial piston unit.

■ Rate of pressure change RA

Maximum permissible pressure build-up and pressure reduction speed with a pressure change over the entire pressure range.

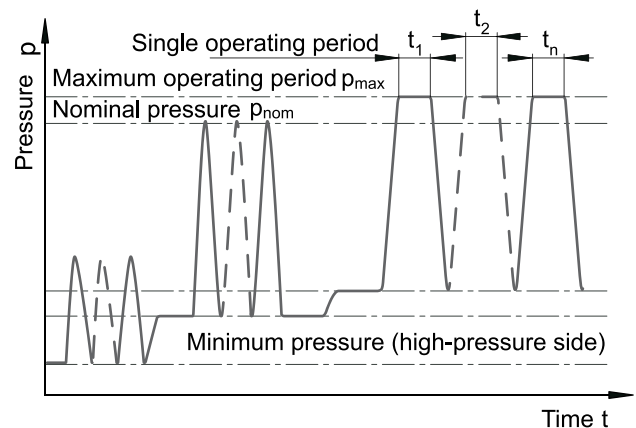

Total operating period = $t_1 + t_2 + \dots + t_n$

HYDRAULIC PUMP

HSP-10VO

TECHNICAL DATA - STANDARD UNIT

Table of values (theoretical values, without efficiencies and tolerances: values rounded)

Size	NG	18	28	45	71	100	140		
Geometrical displacement per revolution	$V_g \text{ max}$ in ³ (cm ³)	1.10(18)	1.71(28)	2.75(45)	4.33(71)	6.10(100)	8.54(140)		
Speed ¹⁾	maximum at $V_g \text{ max}$	n_{nom} rpm	3300	3000	2600	2200	2000	1800	
	maximum at $V_g < V_g \text{ max}$	$n_{\text{max perm}}$ rpm	3900	3600	3100	2600	2400	2100	
Flow n_{nom} and $V_g \text{ max}$	$q_v \text{ max}$	gpm (l/min)	15.7 (59)	22 (84)	31 (117)	41 (156)	53 (200)	67 (252)	
	$n_E = 1800 \text{ rpm}$ and $V_g \text{ max}$	$q_{vE \text{ max}}$	gpm (l/min)	7.2 (32)	13.3 (59)	21.4 (81)	33.8 (128)	47.6 (180)	67 (252)
Power at $\Delta p = 4000 \text{ psi}$ (280 bar) at n_{nom} and $V_g \text{ max}$	P_{max}	HP (kW)	36 (28)	51 (39)	72 (55)	96 (73)	124 (93)	156 (118)	
	$n_E = 1500 \text{ rpm}$ and $V_g \text{ max}$	$P_{E \text{ max}}$	HP (kW)	19 (15)	31 (24)	50 (38)	91 (69)	111 (84)	156 (118)
Torque $V_g \text{ max}$ and	$\Delta p = 4000 \text{ psi}$ (280 bar)	T_{max}	lb-ft (Nm)	58 (80)	91 (125)	146 (200)	230 (316)	324 (445)	453 (623)
	$\Delta p = 1450 \text{ psi}$ (100 bar)	T	lb-ft (Nm)	14.6 (30)	33 (45)	53 (72)	83 (113)	117 (159)	164 (223)
Rotary stiffness, drive shaf	S	C	lb-ft/rad (Nm/rad)	8082 (11087)	16400 (22317)	27560 (37500)	53018 (71884)	89348 (121142)	125042 (169537)
	R	C	lb-ft/rad (Nm/rad)	10870 (14850)	19400 (26360)	30240 (41025)	56456 (76545)	— (—)	— (—)
	P	C	lb-ft/rad (Nm/rad)	— (13158)	— (25656)	— (41232)	— (80627)	— (132335)	— (188406)
	U	C	lb-ft/rad (Nm/rad)	5946 (8090)	— (—)	— (—)	— (—)	67180 (91093)	— (—)
	K	C	lb-ft/rad (Nm/rad)	9805 (13340)	19712 (26189)	32270 (43905)	60352 (82112)	99448 (135303)	144680 (188406)
Moment of inertial rotary group	J_{TW}	lbs-ft ² (kgm ²)	0.022 (0.00093)	0.0403 (0.0017)	0.0783 (0.0033)	0.1970 (0.0083)	0.3963 (0.0167)	0.5743 (0.0242)	
Angular acceleration, maximum ²⁾	α	rad/s ²	6800	5500	4000	3300	2700	2700	
Filling capacity	V	gal (L)	01.(0.4)	0.2(0.7)	0.26(1.0)	0.4(1.6)	0.6(2.2)	0.8(3.0)	
Weight (without through drive)	m	lbs (kg)	26.5(12)	33(15)	46(21)	73(33)	99(45)	132(60)	

The values are applicable :

- ¹⁾ for an absolute pressure $p_{\text{abs}} = 15 \text{ psi}$ (1 bar) at suction port S
 - within the optimum viscosity range from $\nu_{\text{opt}} = 80$ to 170 SUS (16 to $36 \text{ mm}^2/\text{s}$)
 - for mineral-oil based hydraulic fluid.

- ²⁾ The scope of application lies between the minimum necessary and the maximum permissible drive speeds. Valid for external excitation(e.g. diesel engine 2- to 8-fold rotary frequency, cardan shaft 2-fold rotary frequency). The limiting value is only valid for a single pump. The loading capacity of the connecting parts must be taken into account.

Note

Exceeding the maximum or falling below the minimum permissible values can lead to a loss of function, a reduction in operational life or total destruction of the axial piston unit. We recommend to check the loading through tests or calculation / simulation and comparison with the permissible values.

Determination of size

Flow	$q_v = \frac{V_g \cdot n \cdot \eta_v}{231(1000)}$	[gpm l/min]	$V_g =$ Displacement per revolution in in ³ (cm ³)
Torque	$T = \frac{V_g \cdot \Delta p}{24(20) \cdot p \cdot \eta_{mh}}$	[lb-ft Nm]	$\Delta p =$ Differential pressure in psi (bar)
Power	$P = \frac{2\pi \cdot T \cdot n}{33000(60000)} = \frac{q_v \cdot \Delta p}{1714(600) \cdot \eta_t}$	[HP kW]	$n =$ Speed in rpm (rpm)
			$\eta_v =$ Volumetric efficiency
			$\eta_{mh} =$ Mechanical-hydraulic efficiency
			$\eta_t =$ Total efficiency ($\eta_t = \eta_v \cdot \eta_{mh}$)

HYDRAULIC PUMP

HSP-10VO

TECHNICAL DATA - HIGH SPEED VERSION

Table of values (theoretical values, without efficiencies and tolerances: values rounded)

Size	NG	45	71	100	140		
Geometrical displacement per revolution	$V_{g \max}$ in ³ (cm ³)	2.75(45)	4.33(71)	6.1(100)	8.54(140)		
Speed ¹⁾							
maximum at $V_{g \max}$	n_{nom} rpm	3000	2550	2300	2050		
maximum at $V_g < V_{g \max}$	$n_{\text{max perm}}$ rpm	3300	2800	2500	2200		
Flow n_{nom} and $V_{g \max}$	$Q_{v \max}$ gpm (l/min)	35 (135)	48 (178)	61 (230)	76 (287)		
Power at $\Delta p = 4000$ psi (280 bar) at n_{nom} and $V_{g \max}$	P_{max} HP (kW)	83 (63)	112 (83)	142 (107)	177 (134)		
Torque $V_{g \max}$ and	$\Delta p = 4000$ psi (280 bar) T_{max} lb-ft (Nm)	146 (200)	230 (316)	324 (445)	453 (623)		
	$\Delta p = 1450$ psi (100 bar) T lb-ft (Nm)	53 (72)	83 (113)	117 (159)	164 (223)		
Rotary stiffness, drive shaf	S	C	lb-ft/rad (Nm/rad)	27560 (37500)	53018 (71884)	89348 (121142)	125042 (169537)
	R	C	lb-ft/rad (Nm/rad)	30240 (41025)	56456 (76545)	– (–)	–
	P	C	lb-ft/rad (Nm/rad)	– (41232)	– (80627)	– (132335)	– (188406)
	U	C	lb-ft/rad (Nm/rad)	– (–)	– (–)	67180 (91093)	– (–)
	K	C	lb-ft/rad (Nm/rad)	32270 (43950)	60352 (82112)	99448 (135303)	144680 (188406)
Moment of inertial rotary group	J_{TW} lbs-ft ² (kgm ²)	0.0783 (0.0033)	0.1970 (0.0083)	0.3963 (0.0167)	0.5743 (0.0242)		
Angular acceleration, maximum ²⁾	α rad/s ²	4000	3300	2700	2700		
Filling capacity	V gal (L)	0.26(1.0)	0.4(1.6)	0.6(2.2)	0.8(3.0)		
Weight (without through drive)	m lbs (kg)	46(21)	73(33)	99(45)	132(60)		

The values are applicable :

¹⁾- for an absolute pressure $p_{\text{abs}} = 15$ psi(1 bar) at suction port S

- within the optimum viscosity range from $\nu_{\text{opt}} = 80$ to 170 (16 to 36 mm²/s)
- for mineral-oil based hydraulic fluid.

²⁾ The scope of application lies between the minimum necessary and the maximum permissible drive speeds. Valid for external excitation (e.g. diesel engine 2- to 8-fold rotary frequency, cardan shaft 2-fold rotary frequency) The limiting value is only valid for a single pump. The loading capacity of the connecting parts must be taken into account.

Note

Exceeding the maximum or falling below the minimum permissible values can lead to a loss of function, a reduction in operational service life or total destruction of the axial piston unit. We recommend to check the loading through tests or calculation / simulation and comparison with the permissible values.

Sizes 45, 71, 100 and 140 are optionally available in high-speed version.
External dimensions are not affected by this option.

HYDRAULIC PUMP

HSP-10VO

TECHNICAL DATA

Permissible radial and axial loading on the drive shaft

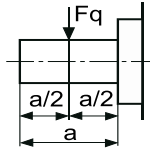
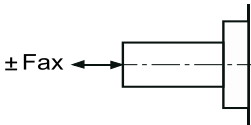
Size	NG	18	28	45	71	100	140	
Radial force maximum at a/2		$F_{q \max}$ lbf (N)	79 (350)	270 (1200)	337 (1500)	427 (1900)	517 (2300)	630 (2800)
Axial force maximum		$\pm F_{ax \max}$ lbf (N)	157 (700)	225 (1000)	337 (1500)	540 (2400)	900 (4000)	1080 (4800)

Permissible input and through-drive torques

Size	NG	18	28	45	71	100	140	
Torque	T_{\max}	lb-ft (Nm)	58(80)	91(125)	146(200)	230(316)	324(445)	453(623)
at $V_g \max$ and $\Delta p = 4000 \text{ psi (280 bar)}^1$								
Input torque for drive shaft, maximum ²⁾	$T_{E \max}$	lb-ft (Nm)	92(124)	146(198)	235(319)	462(626)	814(1104)	1195(1620)
S	\emptyset	in	3/4	7/8	1	1 1/4	1 1/2	1 3/4
R	$T_{E \max}$	lb-ft (Nm)	118(160)	184(250)	295(400)	475(644)	– (–)	– (–)
	\emptyset	in	3/4	7/8	1	1 1/4	–	–
P	$T_{E \max}$	lb-ft (Nm)	– (88)	– (137)	– (200)	– (439)	– (857)	– (1206)
	\emptyset	mm	18	22	25	32	40	45
U	$T_{E \max}$	lb-ft (Nm)	43(59)	– (–)	– (–)	– (–)	439(595)	– (–)
	\emptyset	in	5/8	–	–	–	1 1/4	–
K	$T_{E \max}$	lb-ft (Nm)	77(104)	107(145)	156(212)	319(433)	553(750)	875(1186)
	\emptyset	in	0.7500	0.8750	1.0000	1.2500	1.5000	1.7500
		(mm)	(19.05)	(22.225)	(25.4)	(31.75)	(38.1)	(44.45)
Maximum through-drive torque for drive shaft	$T_{D \max}$	lb-ft (Nm)	80(108)	118(160)	235(319)	363(492)	574(778)	934(1266)
S	$T_{D \max}$	lb-ft (Nm)	88(120)	130(176)	269(365)	404(548)	– (–)	– (–)
R	$T_{D \max}$	lb-ft (Nm)	– (88)	– (137)	– (200)	– (439)	– (778)	– (1206)
P	$T_{D \max}$	lb-ft (Nm)	77(104)	107(145)	156(212)	319(433)	553(750)	875(1186)
K	$T_{D \max}$	lb-ft (Nm)	77(104)	107(145)	156(212)	319(433)	553(750)	875(1186)

¹⁾ Without considering efficiency

²⁾ For drive shafts free of radial load

Distribution of torques

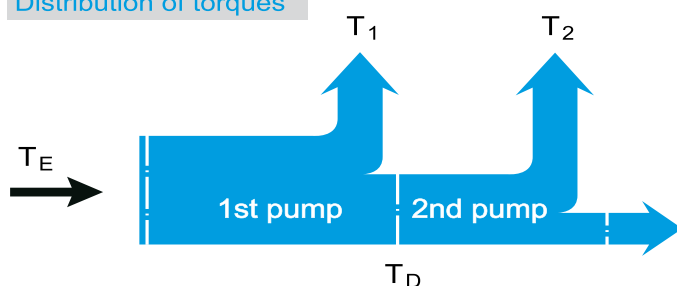

HYDRAULIC PUMP

HSP-10VO

TECHNICAL DATA

Drive power

Working position :

Flow ISO VG 46 DIN 51519 · t = 50 °C

size 18

--- n = 1500 rpm
 — n = 3300 rpm

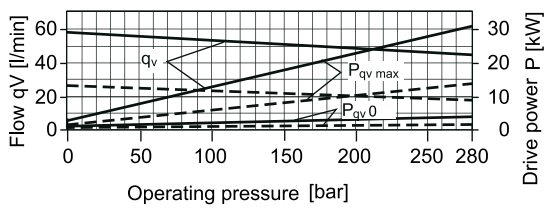

size 28

--- n = 1500 rpm
 — n = 3000 rpm

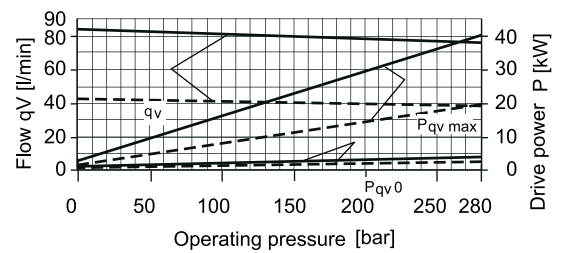

size 45

--- n = 1500 rpm
 — n = 2600 rpm

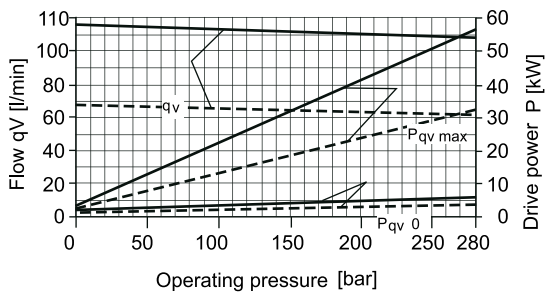

size 71

--- n = 1500 rpm
 — n = 2200 rpm

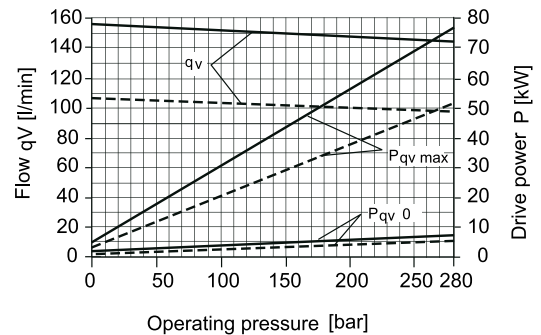

size 100

--- n = 1500 rpm
 — n = 2000 rpm

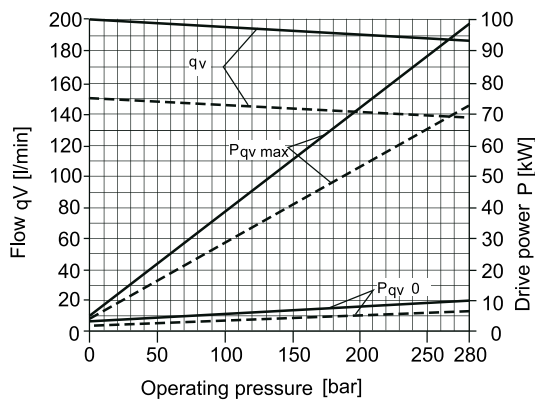

size 140

--- n = 1500 rpm
 — n = 1800 rpm

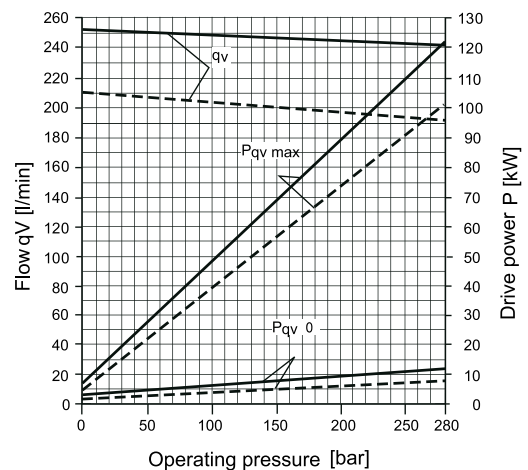

HYDRAULIC PUMP

HSP-10VO

DR - PRESSURE CONTROL

The pressure control limits the maximum pressure at the pump output within the pump control range. The variable pump only supplies as much hydraulic fluid as is required by the consumers. If the operating pressure exceeds the pressure setpoint set at the integrated pressure valve, the pump will adjust towards a smaller displacement and the control deviation will be reduced. The pressure can be set steplessly at the control valve.

Static characteristic

(at $n_1 = 1800 \text{ rpm}$; $t_{\text{fluid}} = 122^\circ\text{F}$ ($50 \text{ }^\circ\text{C}$)

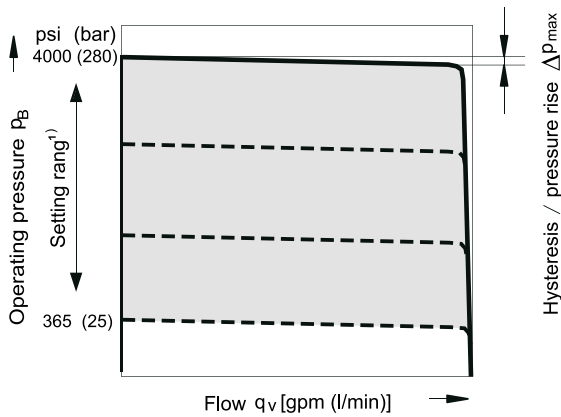

¹⁾In order to prevent damage to the pump and the system, this setting range is the permissible setting range and must not be exceeded. The range of possible settings at the valve are greater.

Circuit diagram, sizes 18 to 100

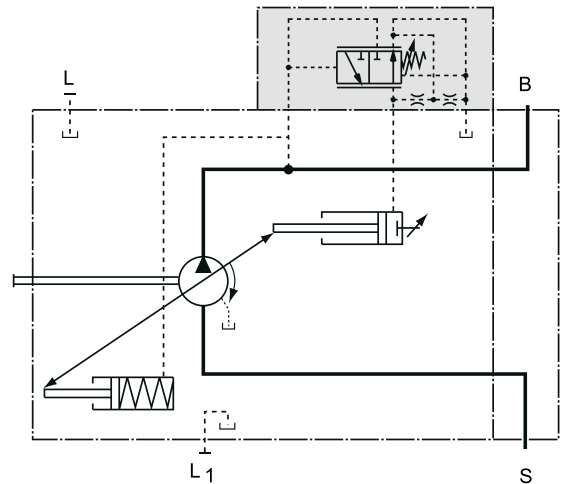

Circuit diagram, size 140

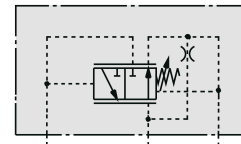

	Port for
B	Service line
S	Suction line
L \ L1	Case drain (L1 plugged)

Control data

Hysteresis and repeatability Δp_{max} approx. 3 bar

Pressure rise, maximum

NG	18	28	45	71	100	140
Δp psi	60	60	90	8	115	175
(bar)	(4)	(4)	(6)	(8)	(10)	(12)

Contr. fluid consum___max. approx. 0.8 gpm (3 l/min)
please following page 8

HYDRAULIC PUMP

HSP-10VO

DRG - PRESSURE CONTROL, REMOTELY OPERATED

A pressure relief valve can be externally piped to port X for remote setting of pressure below the setting of the DR control valve spool. This relief valve is not included in the delivery contents of the DRG control.

The differential pressure at the DRG control valve is set as standard to 290 psi (20 bar). This results in a pilot oil flow to the relief valve of approx. 0.4 gpm (1.5 l/min) at port X. If another setting is required (range from 145 to 320 psi (10-22 bar)) please state in clear text.

The max. length of piping should not exceed 6.6 ft (2m).

Static characteristic

(at $n_1 = 1800 \text{ rpm}$; $t_{\text{fluid}} = 122^\circ\text{F}$ (50 °C))

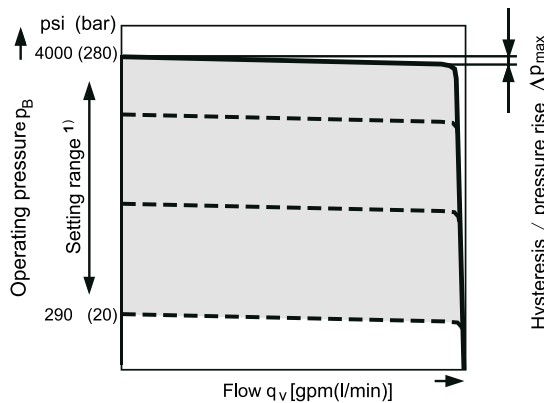

¹⁾ In order to prevent damage to the pump and the system, this setting range is the permissible setting range and must not be exceeded.

The range of possible settings at the valve are greater.

Circuit diagram, sizes 18 to 100

Not included in the delivery contents

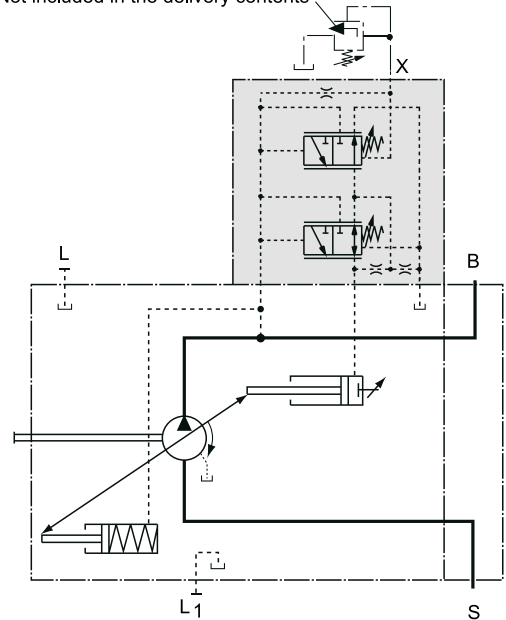

Circuit diagram, size 140

Not included in the delivery contents

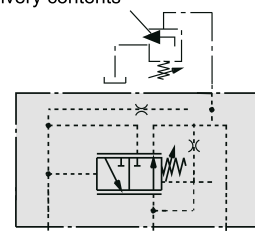

		Port for
B		Service line
S		Suction line
L · L1		Case drain (L1 plugged)
X	NG 18 to 100 without adapter	Pilot pressure
X	NG 140 with adapter	Pilot pressure

Control data

Hysteresis and repeatability Δp_{max} approx. 45 psi (3 bar)

Pressure rise, maximum

NG	18	28	45	71	100	140
Δp psi	60	60	90	115	145	175
(bar)	(4)	(4)	(6)	(8)	(10)	(12)

Contr. fluid consum__max approx. 1.2 gpm (4.5 l/min)
please following page 8

HYDRAULIC PUMP

HSP-10VO

DFR/DFR1 - PRESSURE AND FLOW CONTROL

In addition to the pressure control function, the pump flow may be varied by means of a differential pressure over an adjustable orifice (e.g. directional valve) installed in the service line to the actuator. The pump flow is equal to the actual required flow by the actuator, regardless of changing pressure levels.

The pressure control overrides the flow control function.

Note

The DFR1 version has no connection between X and the reservoir. Unloading the LS-pilot line must be possible in the valve system. Because of the flushing function sufficient unloading of the X-line must also be provided.

Static characteristic

Flow control at $n_1 = 1500 \text{ rpm}$; $t_{\text{fluid}} = 122^\circ\text{F}(50^\circ\text{C})$

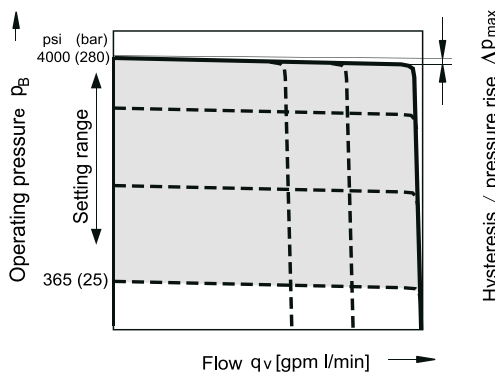

- 1) In order to prevent damage to the pump and the system, this setting range is the permissible setting range and must not be exceeded. The range of possible settings at the valve are greater.

Static characteristic at variable speed

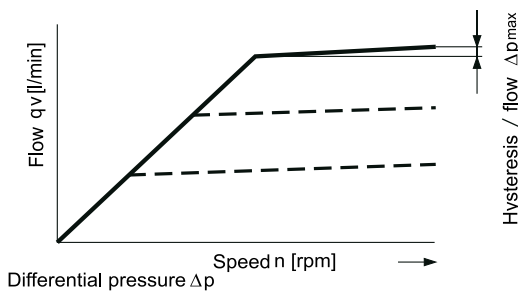

Standard setting : 200 to 320 psi (14 to 22 bar).
 If another setting is required, please state in clear text.
 Relieving the load on port X to the reservoir results in a zero stroke ("standby") pressure which lies about 15 to 30 psi (1 to 2 bar) higher than the differential pressure Δp . System influences are not taken into account.

Circuit diagram, sizes 18 to 100

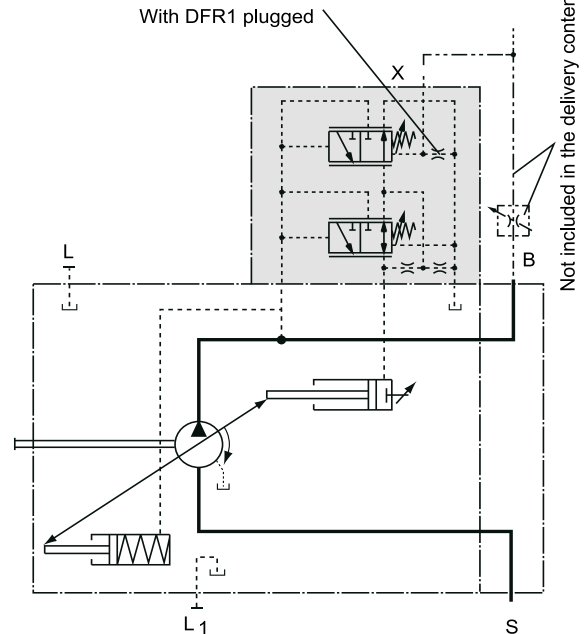

Circuit diagram, size 140

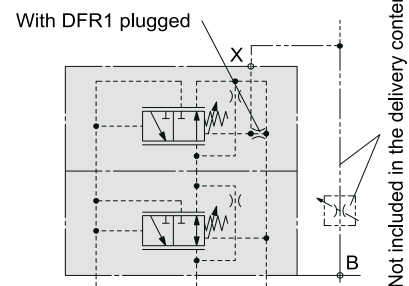

	Port for
B	Service line
S	Suction line
L, L1	Case drain (L1 plugged)
X	Pilot pressure

Control data

Data for pressure control DR, please following page 9
 Maximum flow deviation measured at drive speed $n = 1500 \text{ rpm}$.

NG	18	28	45	71	100	140
$\Delta q_v \text{ max}$	0.24	0.26	0.48	0.75	1.06	1.60
	(0.9)	(1.0)	(1.8)	(2.8)	(4.0)	(6.0)
Contr fluid consum. DFR	__max. approx. 0.8 to 1.2 gpm (3 to 4.5 l/min)					
Contr fluid consum. DFR1	__max. approx. 0.8 gpm (3 l/min)					

please following page 8

HYDRAULIC PUMP

DFLR - PRESSURE, FLOW AND POWER

Execution of the pressure control like, DR / DR(G), please following page 9-10
 Execution of the flow control like DFR, DFR1, please following page 11

In order to achieve a constant drive torque with varying operating pressures, the swivel angle and with it the output flow from the axial piston pump is varied so that the product of flow and pressure remains constant.

Flow control is possible below the power control curve.

Static curves and torque characteristic

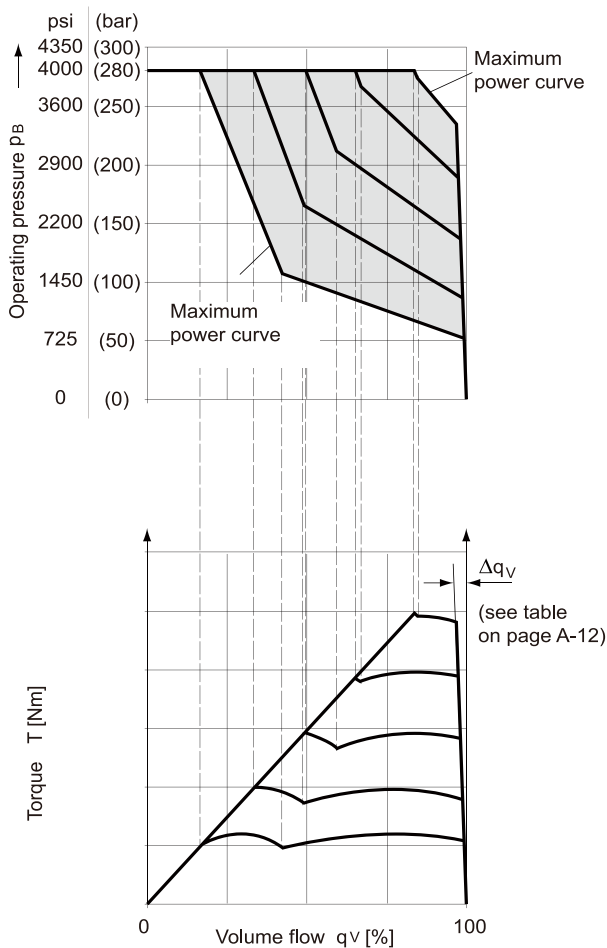

Control data

Beginning of control _____ 735 psi (50 bar)
 Control fluid consumption_max.approx. 1.45 gpm (5.5 l/min)
 please following page 8

	Port for
B	Service line
S	Suction line
L、L1	Case drain (L1 plugged)
X	Pilot pressure

The power characteristic is set in the factory; when ordering, please state in clear text, e.g. 27HP (20 kW) at 1800 rpm

Control data

For pressure control DR data, please following page 9

For flow control DFR / DFR1 data, please following page 11

Circuit diagram, sizes 28 to 100

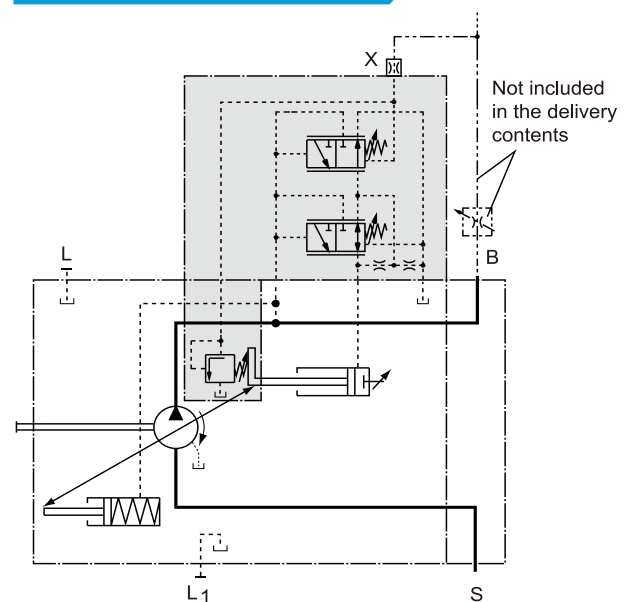

Circuit diagram, size 140

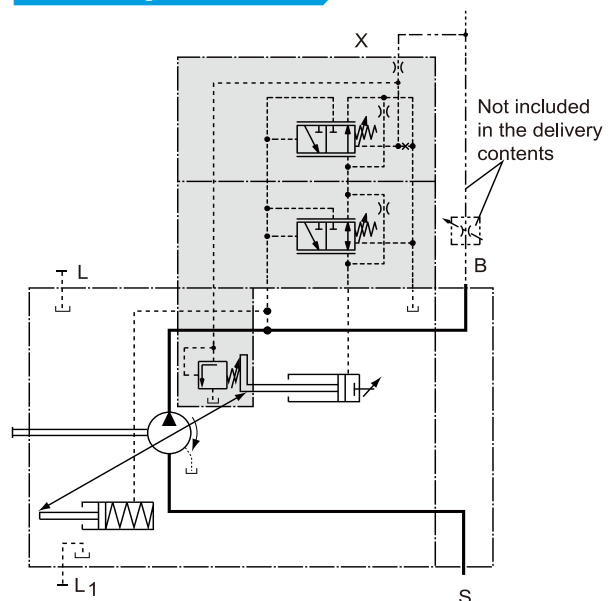

HYDRAULIC PUMP

HSP-10VO

HC/HO - PRESSURE ELECTRICAL ON-OFF

Combined with a mechanical compensator (ex. DFRHO)

The HC/HO has a venting function; when a long unloading time is required and heat generation and noise have to be kept at lowest level

When ordering, state the type of application in clear text.

Static flow-pressure characteristic

(at $n_1 = 1800 \text{ rpm}$; $t_{\text{fluid}} = 122^\circ\text{F}$ (50 °C))

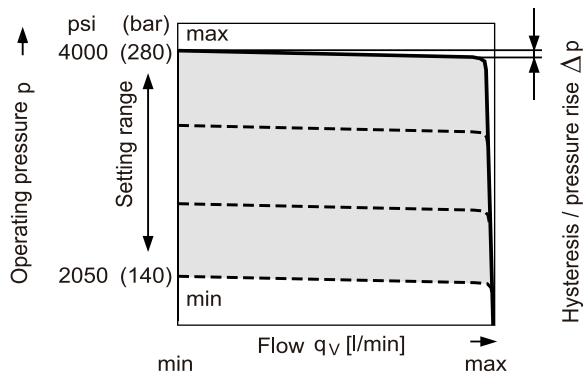

Circuit diagram HC/HO

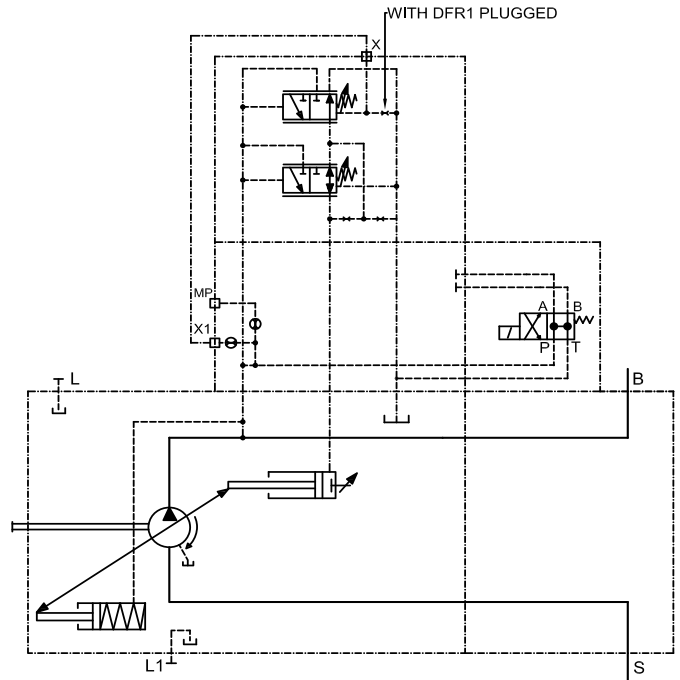

Control data

Stand-by standard setting 290 psi (20 bar), other values on request.

Hysteresis and pressure rise $\Delta p < 60 \text{ psi}$ (4 bar)

Control fluid consumption 0.8 to 1.2 gpm (3 to 4.5 l/min)

	Port for
B	Service line
S	Suction line
L · L1	Case drain (L1 plugged)
X1	Piloting Line
MP	Pressure Test Port

HYDRAULIC PUMP

HSP-10VO

ERHZ - ELECTRO-HYDRAULIC PRESSURE CONTROL

The ERHZ valve is set to a specific pressure by a specified, variable solenoid current.

If there is a change at the consumer (load pressure), the position of the control piston changes.

This causes an increase or decrease in the pump swivel angle (flow) in order to maintain the electrically set pressure level.

The pump thus only delivers as much hydraulic fluid as the consumers can take. The desired pressure level can be set steplessly by varying the solenoid current.

If the solenoid current drops to zero, the pressure is limited to p_{min} (stand-by).

Static current-pressure characteristic ERHZ

(measured at pump in zero stroke – positive characteristic)

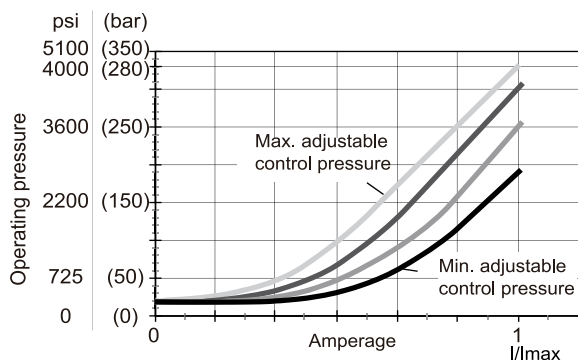

Hysteresis static current-pres. characteristic < 45 psi (3 bar)
Influence of pressure setting on stand-by ± 30 psi (± 2 bar)

Static flow-pressure characteristic

(at $n = 1800$ rpm; $t_{fluid} = 122^\circ F$ ($50^\circ C$))

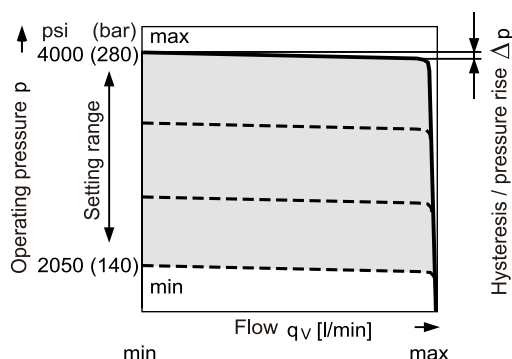

Control data

Standby standard setting 290 psi (20 bar), other values on request.

Hysteresis and pressure increase $\Delta p < 60$ psi (4 bar)
Control fluid consumption 0.8 to 1.2 gpm (3 to 4.5 l/min)

Circuit diagram ERHZ

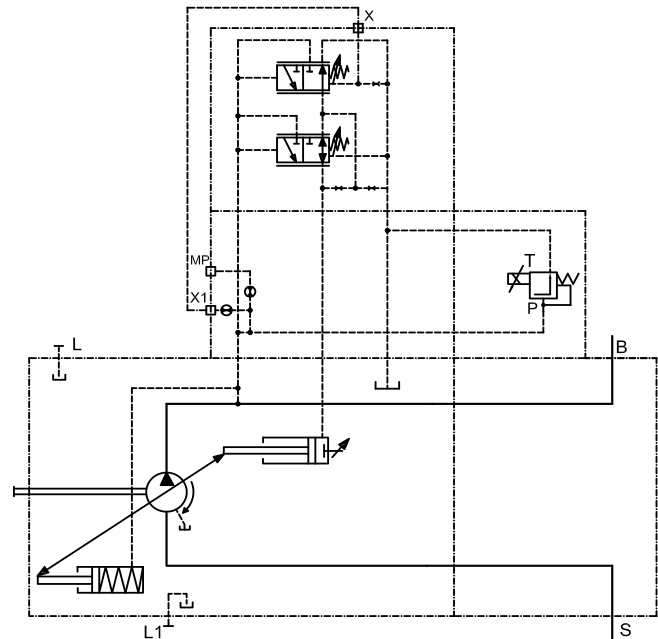

	Port for
B	Service line
S	Suction line
L · L1	Case drain (L1 plugged)

Technical data, solenoid	ERHZ
Voltage	12/24V ($\pm 20\%$)
Control current	
Control begin at $q_{v\ min}$	50 mA
End of control at $q_{v\ max}$	600 mA
Limiting current	0.77 A
Nominal resistance 20°C	22.7 Ω
Dither frequency	100 to 200 Hz
Actuated time	100 %

For type of protection, Please contact us.

Operating temperature range at valve $-4^\circ F$ to $239^\circ F$ ($-20^\circ C$ to $+115^\circ C$)

The following electric controllers and amplifiers are available for controlling the proportional solenoids

- 1) Power outlets for 2 valves, can be actuated separately
- 2) Only 24V nominal voltage

HYDRAULIC PUMP

HSP-10VO

ISO SIZE

DIMENSIONS SIZE 18

DFR, DFR1 – Pressure and flow control, hydraulic

Clockwise rotation

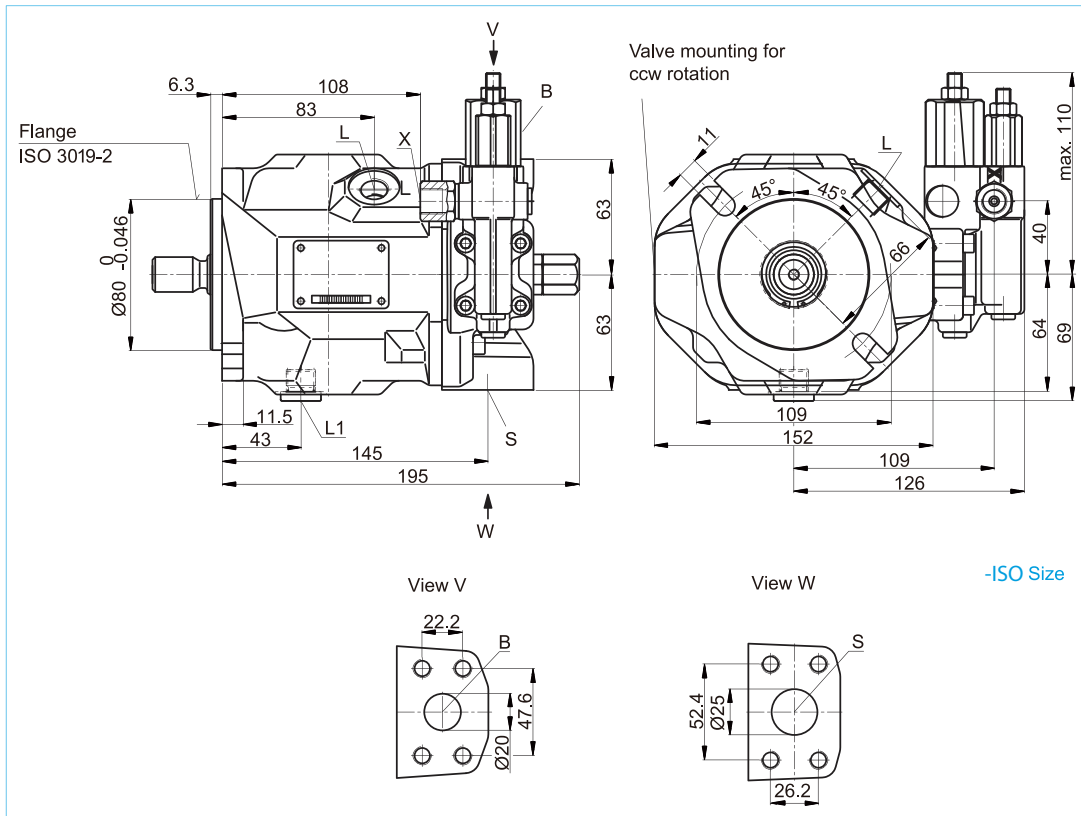

Before finalizing your design request a certified installation drawing. Dimensions in (mm).

Ports

Designation	Port for	Standard	Size ¹⁾	Maximum pressure[psi(bar)] ²⁾	State
B	Service line, fastening thread	SAE J518 ³⁾ DIN 13	3/4 in M10 x 1.5 : 17 (deep)	5100(350)	O
S	Suction line, fastening thread	SAE J518 ³⁾ DIN 13	1 in M10 x 1.5 : 17 (deep)	145(10)	O
L	Case drain fluid	DIN 3852 ⁴⁾	M16 x 1.5 : 12 (deep)	30(2)	O ⁵⁾
L ₁	Case drain fluid	DIN 3852 ⁴⁾	M16 x 1.5 : 12 (deep)	30(2)	X ⁵⁾
X	Pilot pressure	DIN 3852 ⁴⁾	M14 x 1.5 : 12 (deep)	5100(350)	O
X	Pilot press. with DG-control	DIN ISO 228 ⁴⁾	G 1/4 in	5100(350)	O

- 1) For the maximum tightening torques the general instructions on page 51 must be observed.
- 2) Depending on the application, short-term pressure spikes can occur. Keep this in mind when selecting measuring equipment and fittings. Pressure values in bar absolute.
- 3) The dimension follow SAE J518, Metric fastening thread and standard thread are different.
- 4) The spot face can be deeper than as specified in the standard.
- 5) Depending on the installation position, L or L₁ must be connected (the following page 49, please check assembling instruction.)
O = Must be connected (plugged on delivery)
X = Plugged (in normal operation)

HYDRAULIC PUMP

HSP-10VO

SAE SIZE DIMENSIONS SIZE 18

DFR, DFR1 – Pressure and flow control, hydraulic
Clockwise rotation

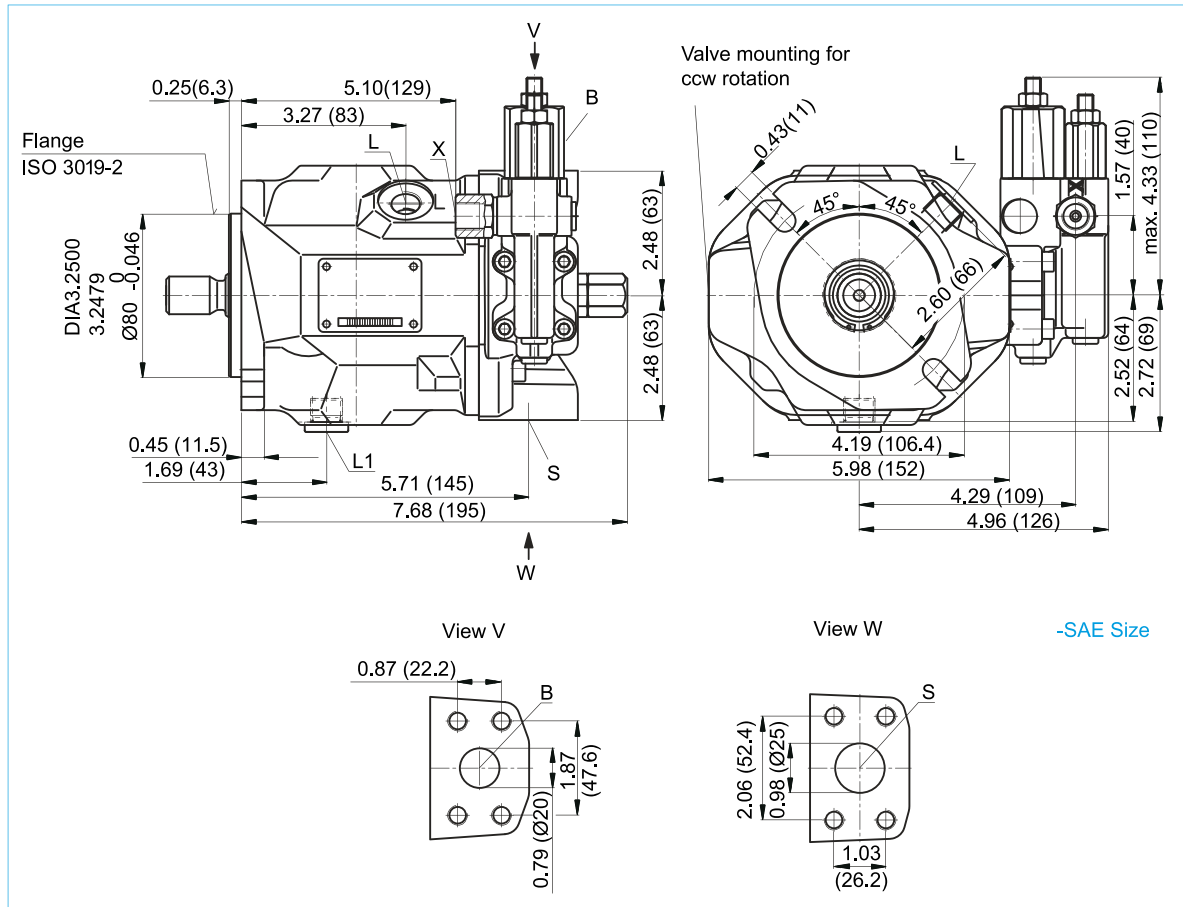

Before finalizing your design request a certified installation drawing.
Dimensions in inches and (mm).

Ports

Designation	Port for	Standard	Size ¹⁾	Maximum pressure [psi(bar)] ²⁾	State
B	Service line, fastening thread	SAE J518 ASME B1.1	3/4 in 3/8-16 UNC-2B; 0.79 (20) deep	5100(350)	O
S	Suction line, fastening thread	SAE J518 ASME B1.1	1 in 3/8-16 UNC-2B; 0.79 (20) deep	145(10)	O
L	Case drain fluid	ISO 11926 ³⁾	9/16-18 UNF-2B; 0.47 (12) deep	30(2)	O ⁴⁾
L1	Case drain fluid	ISO 11926 ³⁾	9/16-18 UNF-2B; 0.47 (12) deep	30(2)	X ⁴⁾
X	Pilot pressure	ISO 11926 ³⁾	7/16-20 UNF-2B; 0.45 (12) deep	5100(350)	O
X	Pilot press. with DG-control	DIN ISO 228 ³⁾	G 1/4 in; 0.47 (12) deep	5100(350)	O

- For the maximum tightening torques the general instructions on page 51 must be observed.
- Depending on the application, short-term pressure spikes can occur. Keep this in mind when selecting measuring equipment and fittings. Pressure values in bar absolute.
- The spot face can be deeper than as specified in the standard.
- Depending on the installation position, L or L1 must be connected (the following page 49, please check assembling instruction.)
O = Must be connected (plugged on delivery)
X = Plugged (in normal operation)

HYDRAULIC PUMP

HSP-10VO

ISO - SAE SIZE DIMENSIONS SIZE 18

Drive shaft

S Splined shaft 3/4 in
11T 16/32DP¹⁾ (SAE J744)

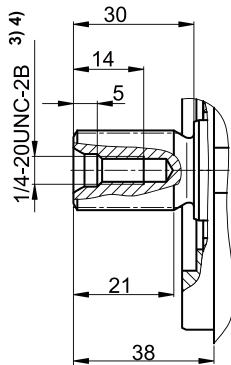

-ISO Size

R Splined shaft 3/4 in
11T 16/32DP¹⁾²⁾ (SAE J744)

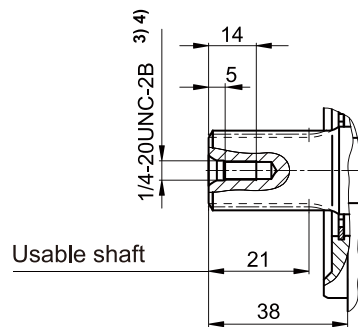

-ISO Size

P Parallel shaft key
DIN 6885 · A6x6x25

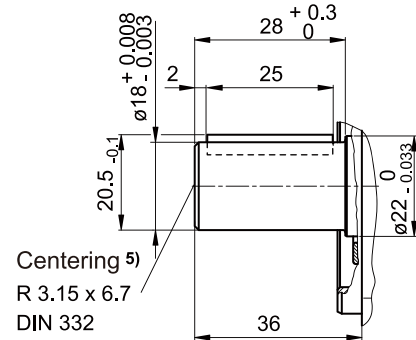

-ISO Size

U Splined shaft 5/8 in
9T 16/32DP¹⁾ (SAE J744)

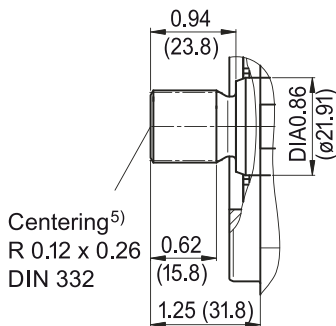

-SAE Size

K Parallel shaft key
ISO 3019-1,19-1

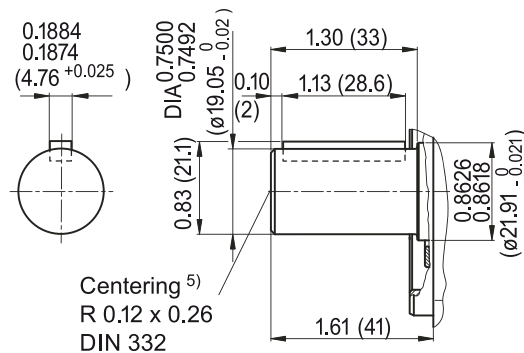

-SAE Size

Before finalizing your design request a certified installation drawing. Dimensions in (mm).

- 1) ANSI B92.1a, 30° pressure angle, flat root, side fit, tolerance class 5
- 2) Splines according to ANSI B92.1a, run out of spline is a deviation from standard
- 3) Thread according to ASME B1.1
- 4) For the maximum tightening torques the general instructions on page 51 must be observed
- 5) Coupling axially secured, e.g. with a clamp coupling or radially mounted clamping screw

HYDRAULIC PUMP

HSP-10VO

ISO SIZE

DIMENSIONS SIZE 18

DR
Pressure control

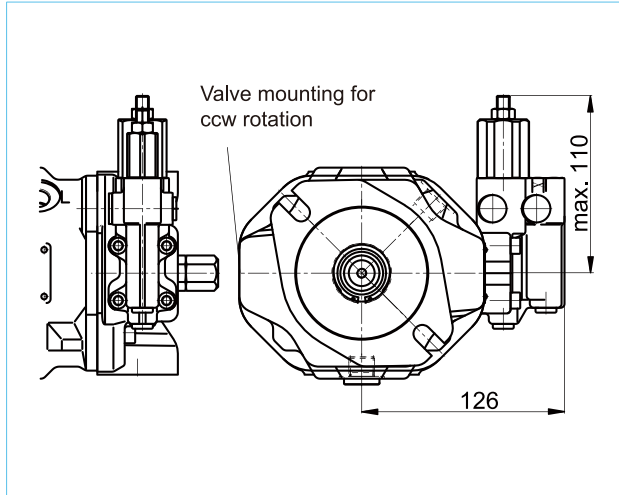

DRG
Pressure control, remotely operated

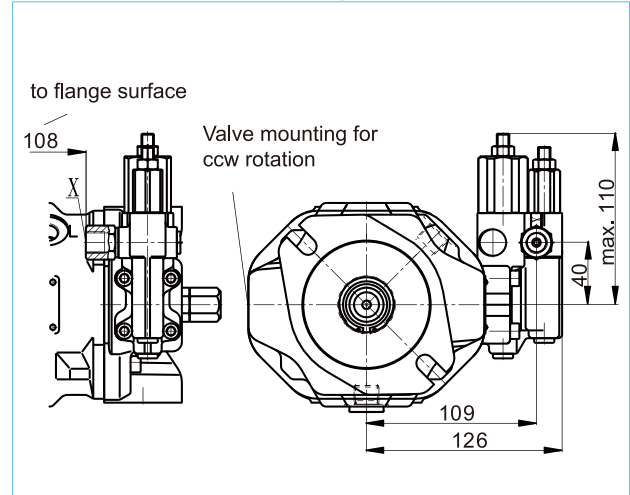

DFR/DFR1
Pressure control, with flow control

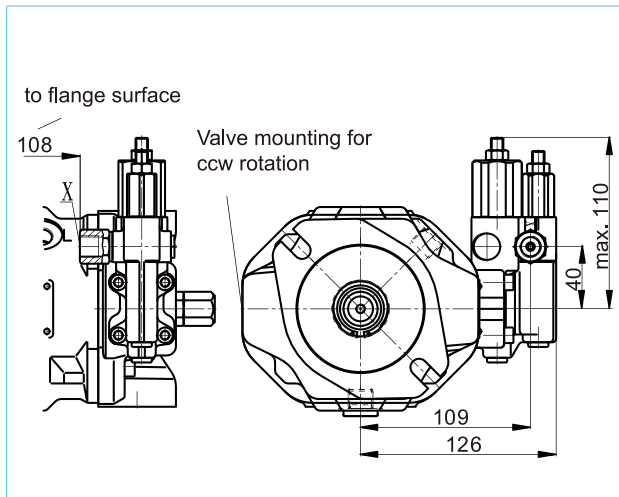

Before finalizing your design request a certified installation drawing.
Dimensions in inches and (mm).

HYDRAULIC PUMP

HSP-10VO

ISO SIZE

DIMENSIONS SIZE 28

DFR/DFR1 – Pressure and flow control, hydraulic

Clockwise rotation

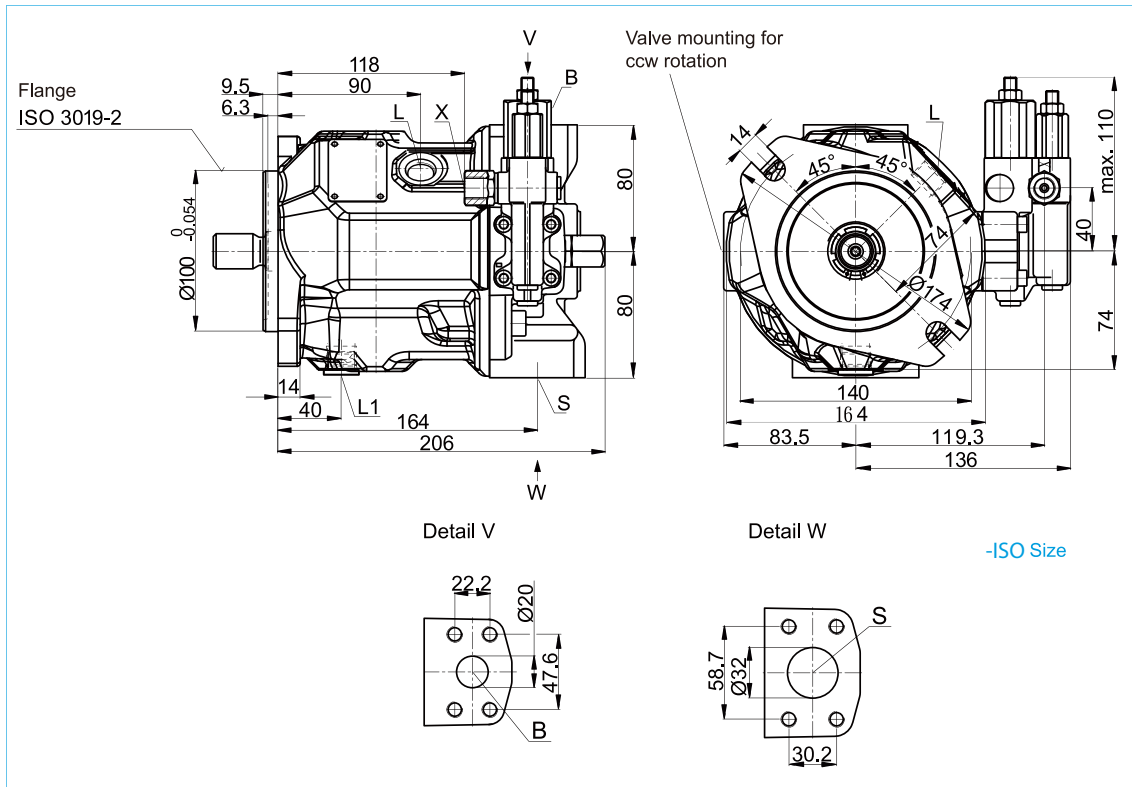

-ISO Size

Before finalizing your design request a certified installation drawing. Dimensions in (mm).

Ports

Designation	Port for	Standard	Size ¹⁾	Maximum pressure[psi(bar)] ²⁾	State
B	Service line, fastening thread	SAE J518 ³⁾ DIN 13	3/4 in M10 x 1.5 : 17 (deep)	5100(350)	O
S	Suction line, fastening thread	SAE J518 ³⁾ DIN 13	1 1/4in M10 x 1.5 : 17 (deep)	145(10)	O
L	Case drain fluid	DIN 3852 ⁴⁾	M18 x 1.5 : 12 (deep)	30(2)	O ⁵⁾
L ₁	Case drain fluid	DIN 3852 ⁴⁾	M18 x 1.5 : 12 (deep)	30(2)	X ⁵⁾
X	Pilot pressure	DIN 3852 ⁴⁾	M14 x 1.5 : 12 (deep)	5100(350)	O
X	Pilot press. with DG-control	DIN ISO 228 ⁴⁾	G 1/4 in : 12 (deep)	5100(350)	O

- 1) For the maximum tightening torques the general instructions on page 51 must be observed.
- 2) Depending on the application, short-term pressure spikes can occur. Keep this in mind when selecting measuring equipment and fittings. Pressure values in bar absolute.
- 3) The dimension follow SAE J518, Metric fastening thread and standard thread are different.
- 4) The spot face can be deeper than as specified in the standard.
- 5) Depending on the installation position, L or L₁ must be connected (the following page 49, please check assembling instruction.)
 O = Must be connected (plugged on delivery)
 X = Plugged (in normal operation)

HYDRAULIC PUMP

HSP-10VO

SAE SIZE DIMENSIONS SIZE 28

DFR/DFR1 – Pressure and flow control, hydraulic
Clockwise rotation

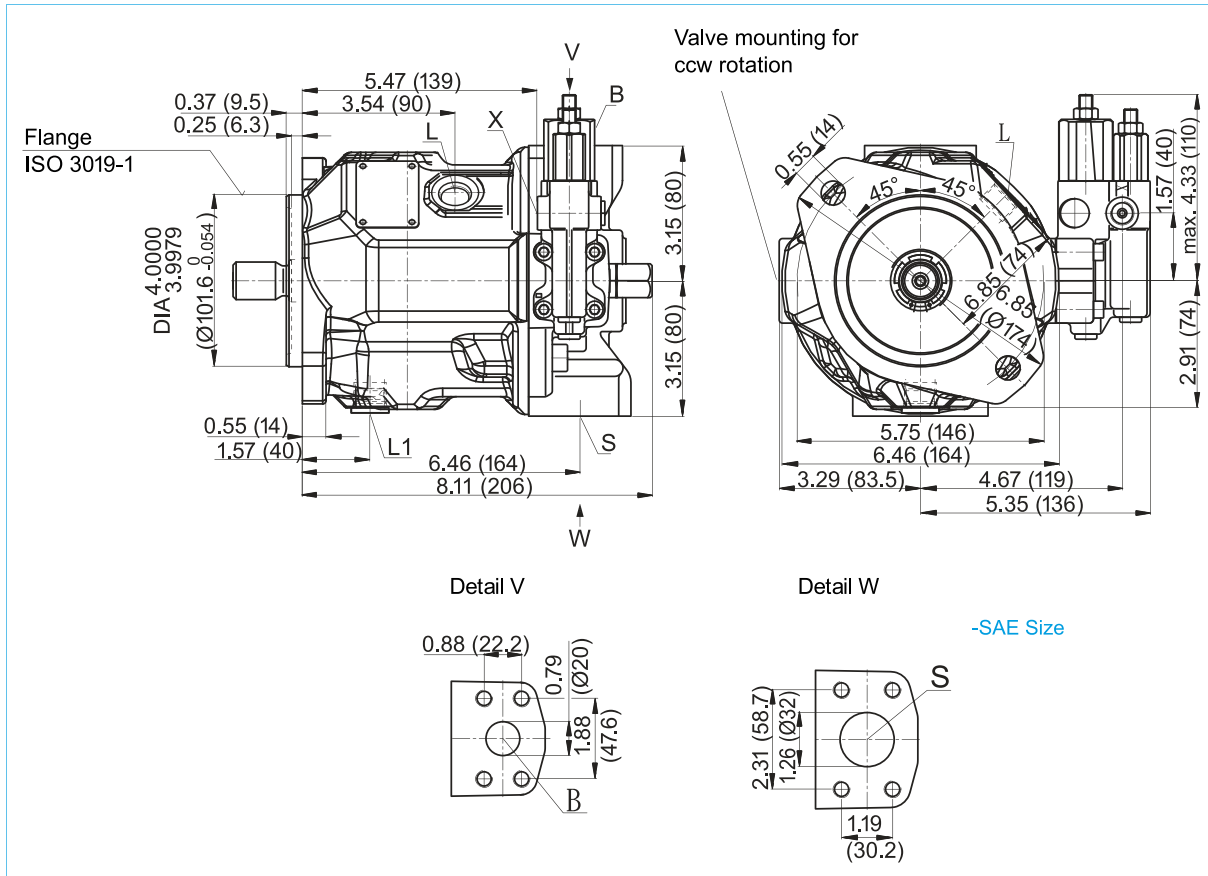

Before finalizing your design request a certified installation drawing.
Dimensions in inches and (mm).

Ports

Designation	Port for	Standard	Size ¹⁾	Maximum pressure[psi(bar)] ²⁾	State
B	Service line, fastening thread	SAE J518 ASME B1.1	3/4 in 3/8-16 UNC-2B; 0.79 (20) deep	5100(350)	O
S	Suction line, fastening thread	SAE J518 ASME B1.1	1 1/4 in 7/16-14 UNC-2B; 0.94 (24) deep	145(10)	O
L	Case drain fluid	ISO 11926 ³⁾	3/4-16 UNF-2B; 0.47 (12) deep	30(2)	O ⁴⁾
L1	Case drain fluid	ISO 11926 ³⁾	3/4-16 UNF-2B; 0.47 (12) deep	30(2)	X ⁴⁾
X	Pilot pressure	ISO 11926 ³⁾	7/16-14 UNC-12B; 0.47 (12) deep	5100(350)	O
X	Pilot press. with DG-control	DIN ISO 228 ³⁾	G 1/4in; 0.47 (12) deep	5100(350)	O

- 1) For the maximum tightening torques the general instructions on page 51 must be observed.
- 2) Depending on the application, short-term pressure spikes can occur. Keep this in mind when selecting measuring equipment and fittings. Pressure values in bar absolute.
- 3) The spot face can be deeper than as specified in the standard.
- 4) Depending on the installation position, L or L1 must be connected (the following page 49, please check assembling instruction.)
O = Must be connected (plugged on delivery)
X = Plugged (in normal operation)

HYDRAULIC PUMP

HSP-10VO

ISO - SAE SIZE DIMENSIONS SIZE 28

Drive shaft

S Splined shaft 7/8 in
13T 16/32DP¹⁾ (SAE J744)

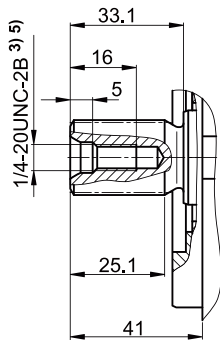

-ISO Size

R Splined shaft 7/8 in
13T 16/32DP¹⁾²⁾ (SAE J744)

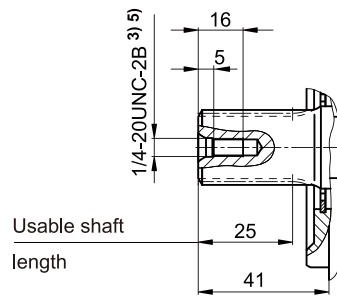

-ISO Size

P Parallel shaft key
DIN 6885 · A6x6x32

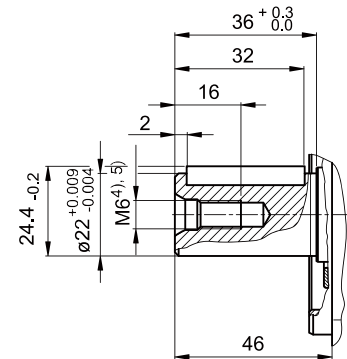

-ISO Size

K Parallel shaft key
ISO 3019-1, 22-1

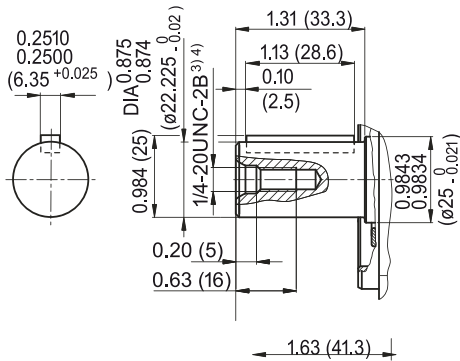

-SAE Size

U Splined Shaft 3/4 in 11T 16/32 DP⁶⁾
SAE J744- 19-4 (A-B)

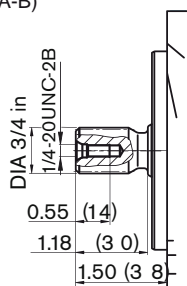

-SAE Size

W Splined Shaft 3/4 in 11T 16/32 DP⁶⁾
SAE J744 - 19-4 (A-B)

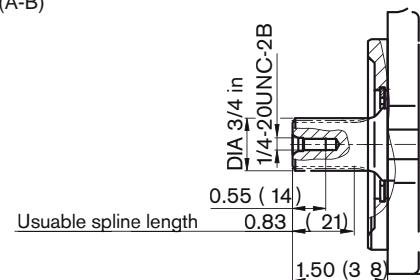

-SAE Size

Before finalizing your design request a certified installation drawing. Dimensions in (mm).

- 1) ANSI B92.1a · 30° pressure angle, flat root, side fit, tolerance class 5
- 2) Splines according to ANSI B92.1a, run out of spline is a deviation from standard
- 3) Thread according to ASME B1.1
- 4) Thread according to DIN 13
- 5) For the maximum tightening torques the general instructions on page 51 must be observed.
- 6) ANSI B92.1a-1976, 30° pressure angle, flat root side fit, flank centering, tolerance class 5

HYDRAULIC PUMP

HSP-10VO

ISO SIZE

DIMENSIONS SIZE 28

DFLR
Pressure, flow and power control

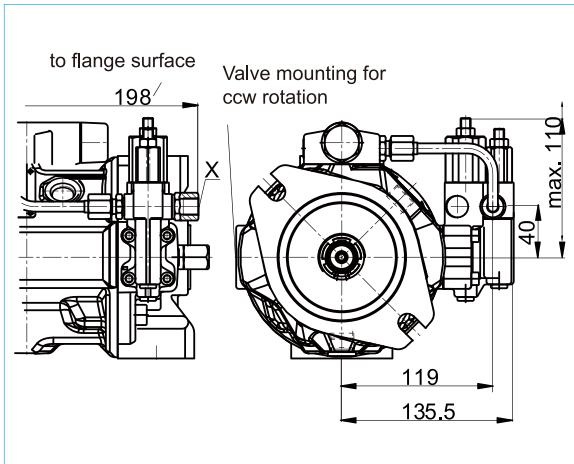

DR
Pressure control

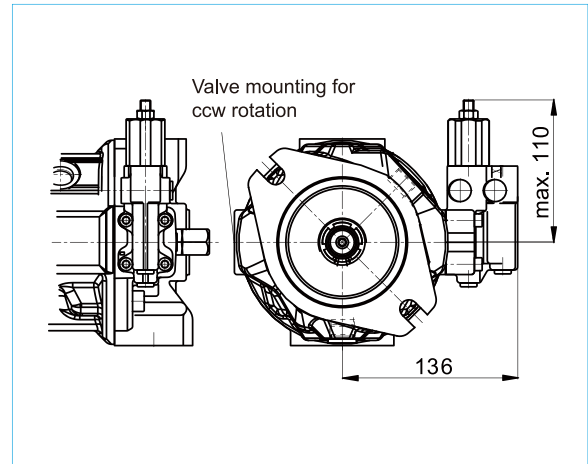

DRG
Pressure control, remotely operated

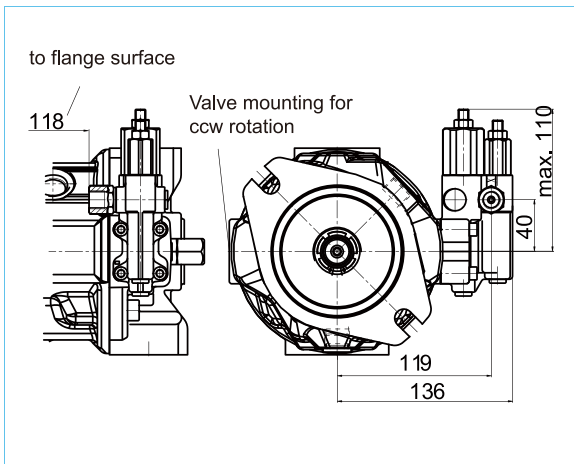

DFR/DFR1
Pressure control, with flow control

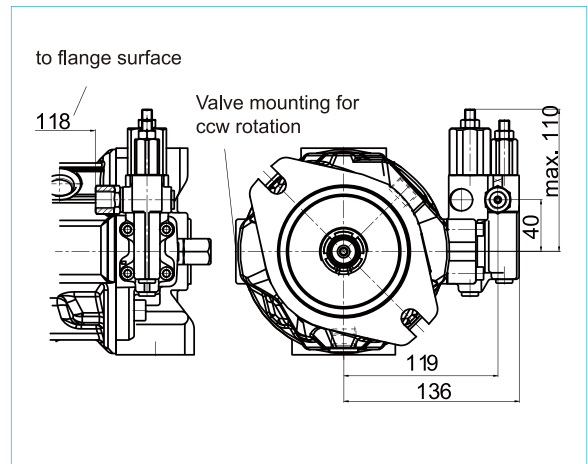

Before finalizing your design request a certified installation drawing. Dimensions in (mm).

HYDRAULIC PUMP

HSP-10VO

ISO SIZE

DIMENSIONS SIZE 45

DFR/DFR1 – Pressure and flow control, hydraulic

Clockwise rotation

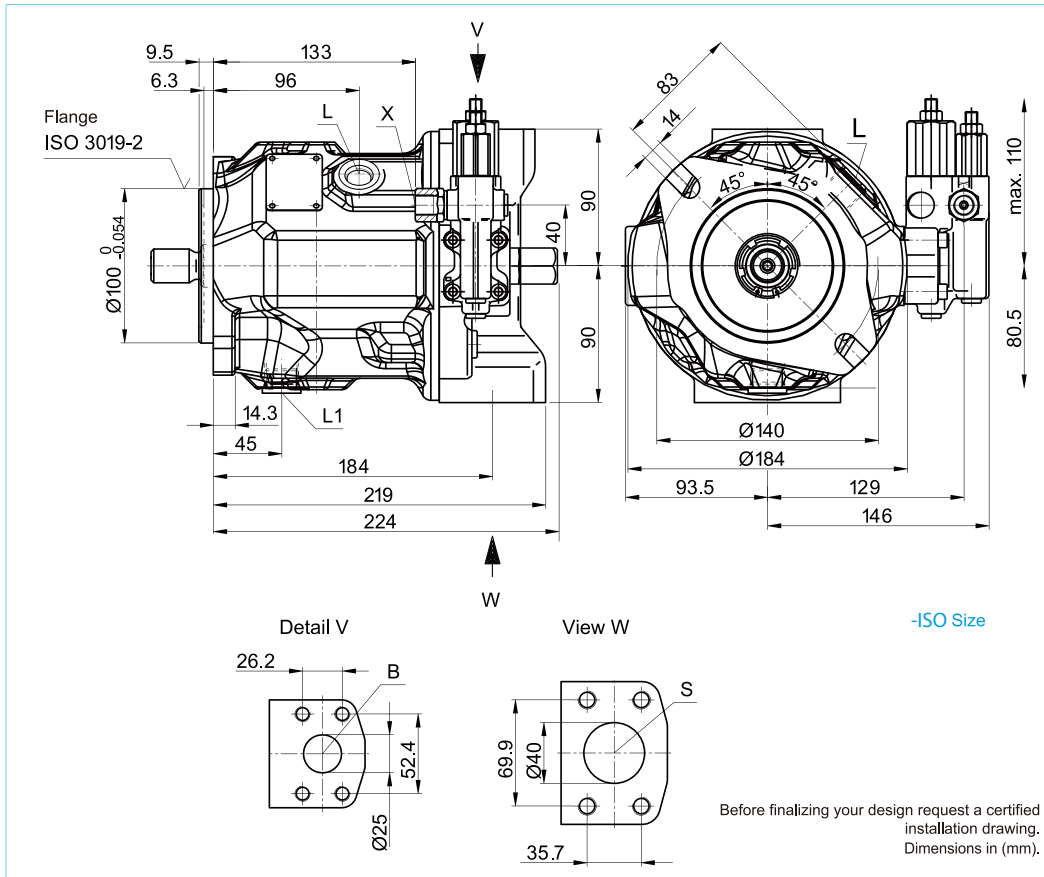

Ports

Designation	Port for	Standard	Size ¹⁾	Maximum pressure[psi(bar)] ²⁾	State
B	Service line, fastening thread	SAE J518 ³⁾ DIN 13	1 in M10 x 1.5 : 17 (deep)	5100(350)	O
S	Suction line, fastening thread	SAE J518 ³⁾ DIN 13	1 1/2in M12 x 1.75 : 20 (deep)	145(10)	O
L	Case drain fluid	DIN 3852 ⁴⁾	M22 x 1.5 : 14 (deep)	30(2)	O ⁵⁾
L ₁	Case drain fluid	DIN 3852 ⁴⁾	M22 x 1.5 : 14 (deep)	30(2)	X ⁵⁾
X	Pilot pressure	DIN 3852 ⁴⁾	M14 x 1.5 : 12 (deep)	5100(350)	O
X	Pilot press. with DG-control	DIN ISO 228 ⁴⁾	G 1/4 in	5100(350)	O

- 1) For the maximum tightening torques the general instructions on page 51 must be observed.
- 2) Depending on the application, short-term pressure spikes can occur. Keep this in mind when selecting measuring equipment and fittings. Pressure values in bar absolute.
- 3) The dimension follow SAE J518, Metric fastening thread and standard thread are different.
- 4) The spot face can be deeper than as specified in the standard
- 5) Depending on the installation position, L or L₁ must be connected (the following page 49, please check assembling instruction.)
O = Must be connected (plugged on delivery)
X = Plugged (in normal operation)

HYDRAULIC PUMP

HSP-10VO

SAE SIZE DIMENSIONS SIZE 45

DFR/DFR1 – Pressure and flow control, hydraulic
Clockwise rotation

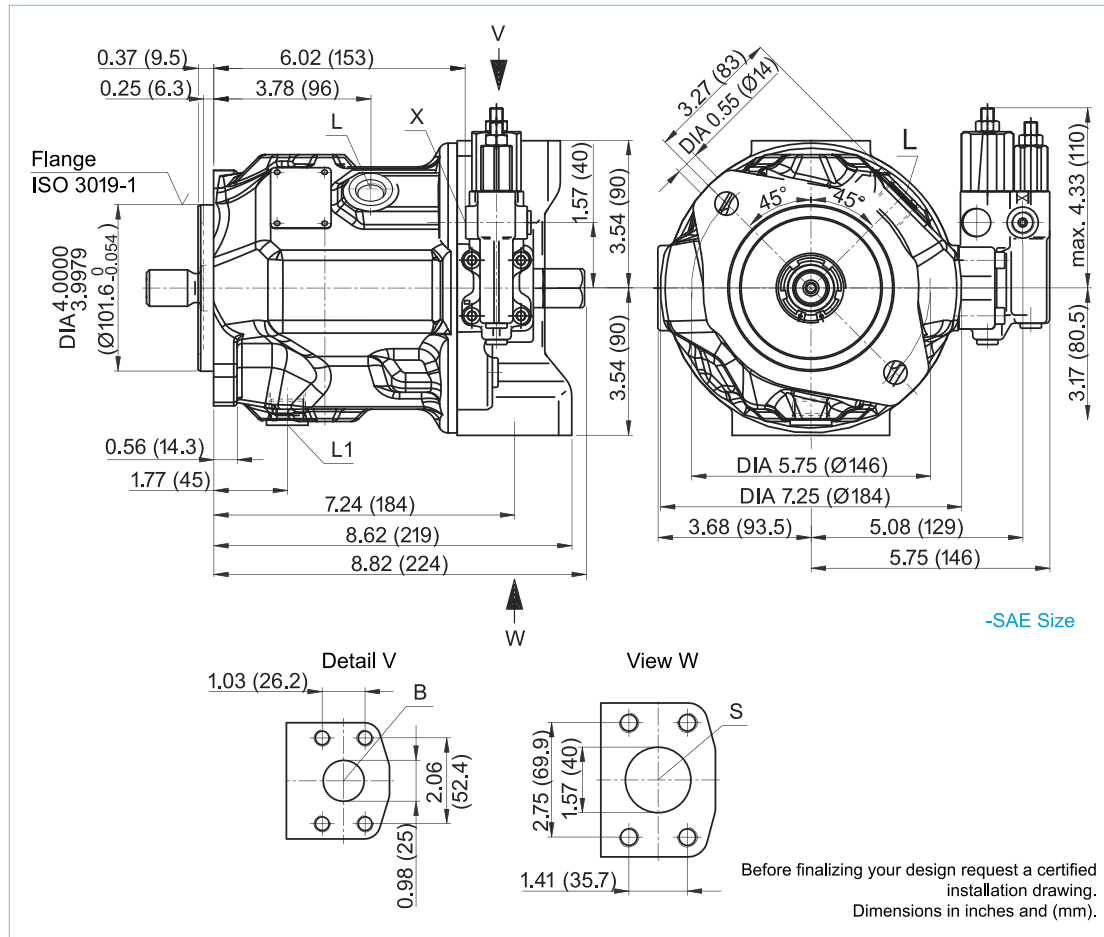

Ports

Designation	Port for	Standard	Size ¹⁾	Maximum pressure[psi(bar)] ²⁾	State
B	Service line, fastening thread	SAE J518 ASME B1.1	1 in 3/8-16 UNC-2B; 0.71 (18) deep	5100(350)	O
S	Suction line, fastening thread	SAE J518 ASME B1.1	1 1/2 in 1/2-13 UNC-2B; 0.87 (22) deep	145(10)	O
L	Case drain fluid	ISO 11926 ³⁾	7/8-14 UNF-2B; 0.55 (14) deep	30(2)	O ⁴⁾
L1	Case drain fluid	ISO 11926 ³⁾	7/8-14 UNF-2B; 0.55 (14) deep	30(2)	X ⁴⁾
X	Pilot pressure	ISO 11926 ³⁾	7/16-20 UNF-2B; 0.45 (12) deep	5100(350)	O
X	Pilot press. with DG-control	DIN ISO 228 ³⁾	G 1/4 in	5100(350)	O

- 1) For the maximum tightening torques the general instructions on page 51 must be observed.
- 2) Depending on the application, short-term pressure spikes can occur. Keep this in mind when selecting measuring equipment and fittings. Pressure values in bar absolute.
- 3) The spot face can be deeper than as specified in the standard.
- 4) Depending on the installation position, L or L1 must be connected (the following page 49, please check assembling instruction.)
O = Must be connected (plugged on delivery)
X = Plugged (in normal operation)

HYDRAULIC PUMP

HSP-10VO

ISO - SAE SIZE DIMENSIONS SIZE 45

Drive shaft

S Splined shaft 1 in
15T 16/32DP¹⁾ (SAE J744)

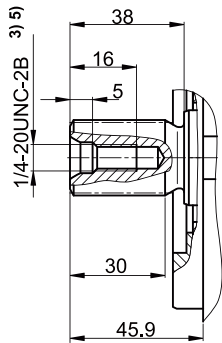

-ISO Size

R Splined shaft 1 in
15T 16/32DP¹⁾²⁾ (SAE J744)

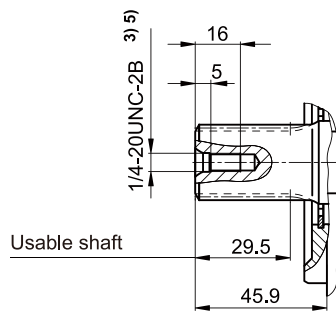

-ISO Size

P Parallel shaft key
DIN 6885 · A8x7x36

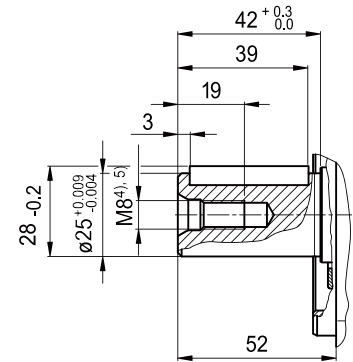

-ISO Size

K Parallel shaft key
ISO 3019-1, 25-1

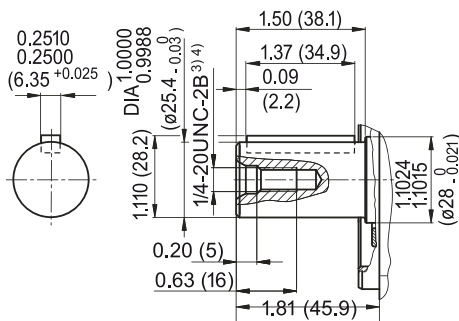

-SAE Size

U Splined shaft 7/8 in 13T 16/32 DP⁶⁾
SAE J744 - 22-4 (B)

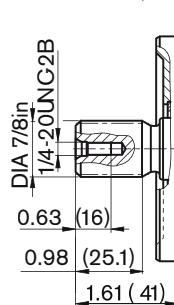

-SAE Size

W Splined shaft 7/8 in 13T 16/32 DP⁶⁾
SAE J744 - 22-4 (B)

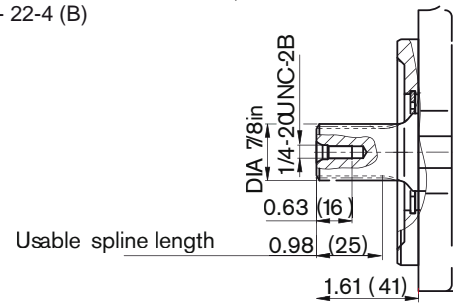

-SAE Size

Before finalizing your design request a certified installation drawing. Dimensions in (mm).

- 1) ANSI B92.1a · 30° pressure angle, flat root, side fit, tolerance class 5
- 2) Splines according to ANSI B92.1a, run out of spline is a deviation from standard
- 3) Thread according to ASME B1.1
- 4) Thread according to DIN 13
- 5) For the maximum tightening torques the general instructions on page 51 must be observed.
- 6) ANSI B92.1a-1976, 30° pressure angle, flat root side fit, flank centering, tolerance class 5

HYDRAULIC PUMP

HSP-10VO

ISO SIZE

DIMENSIONS SIZE 45

DFLR

Pressure, flow and power control

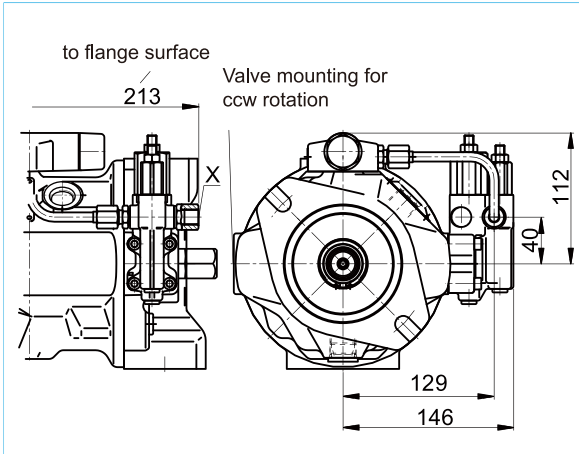

DR

Pressure control

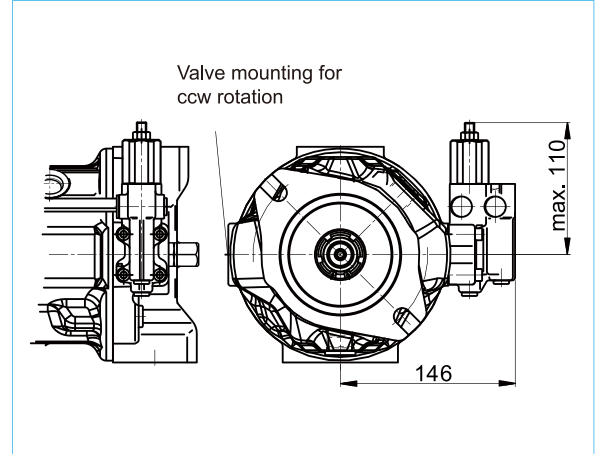

DRG

Pressure control, remotely operated

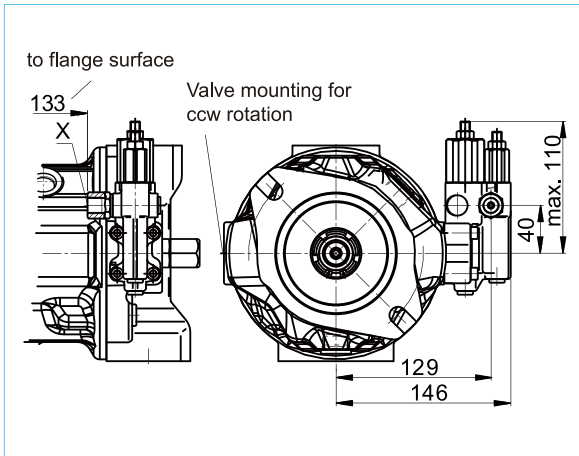

DFR/DFR1

Pressure control, with flow control

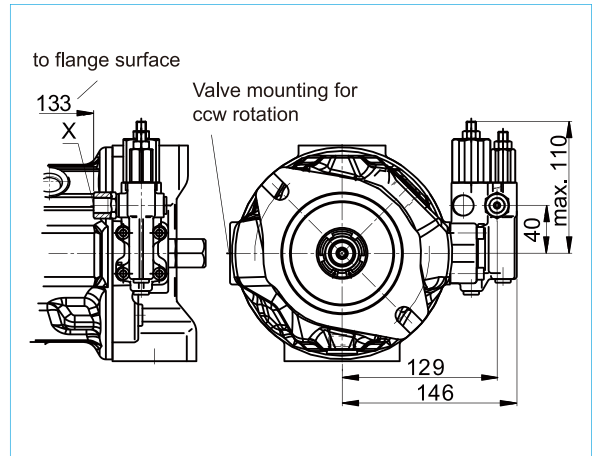

Before finalizing your design request a certified installation drawing. Dimensions in (mm).

HYDRAULIC PUMP

HSP-10VO

ISO SIZE

DIMENSIONS SIZE 7I

DFR/DFR1 – Pressure and flow control, hydraulic

Clockwise rotation

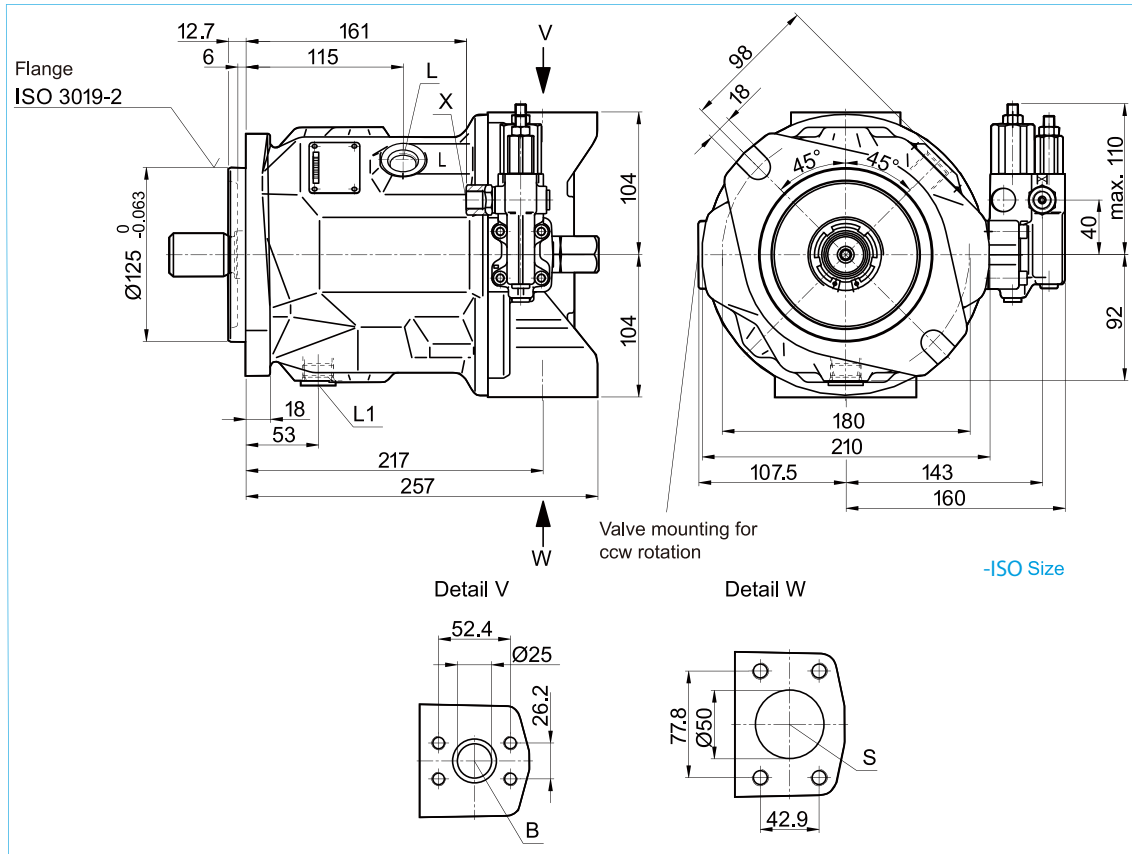

Before finalizing your design request a certified installation drawing. Dimensions in (mm).

Ports

Designation	Port for	Standard	Size ¹⁾	Maximum pressure[psi(bar)] ²⁾	State
B	Service line, fastening thread	SAE J518 ³⁾ DIN 13	1 in M10 x 1.5 : 17 (deep)	500(350)	O
S	Suction line, fastening thread	SAE J518 ³⁾ DIN 13	2 in M12 x 1.75 : 20 (deep)	145(10)	O
L	Case drain fluid	DIN 3852 ⁴⁾	M22 x 1.5 : 14 (deep)	30(2)	O ⁵⁾
L ₁	Case drain fluid	DIN 3852 ⁴⁾	M22 x 1.5 : 14 (deep)	30(2)	X ⁵⁾
X	Pilot pressure	DIN 3852 ⁴⁾	M14 x 1.5 : 12 (deep)	5100(350)	O
X	Pilot press. with DG-control	DIN ISO 228 ⁴⁾	G 1/4 in	5100(350)	O

¹⁾ For the maximum tightening torques the general instructions on page 51 must be observed.

²⁾ Depending on the application, short-term pressure spikes can occur. Keep this in mind when selecting measuring equipment and fittings. Pressure values in bar absolute.

³⁾ The dimension follow SAE J518, Metric fastening thread and standard thread are different.

⁴⁾ The spot face can be deeper than as specified in the standard.

⁵⁾ Depending on the installation position, L or L₁ must be connected (the following page 49, please check assembling instruction.)

O = Must be connected (plugged on delivery)

X = Plugged (in normal operation)

HYDRAULIC PUMP

HSP-10VO

SAE SIZE DIMENSIONS SIZE 7I

DFR/DFR1 – Pressure and flow control, hydraulic

Clockwise rotation

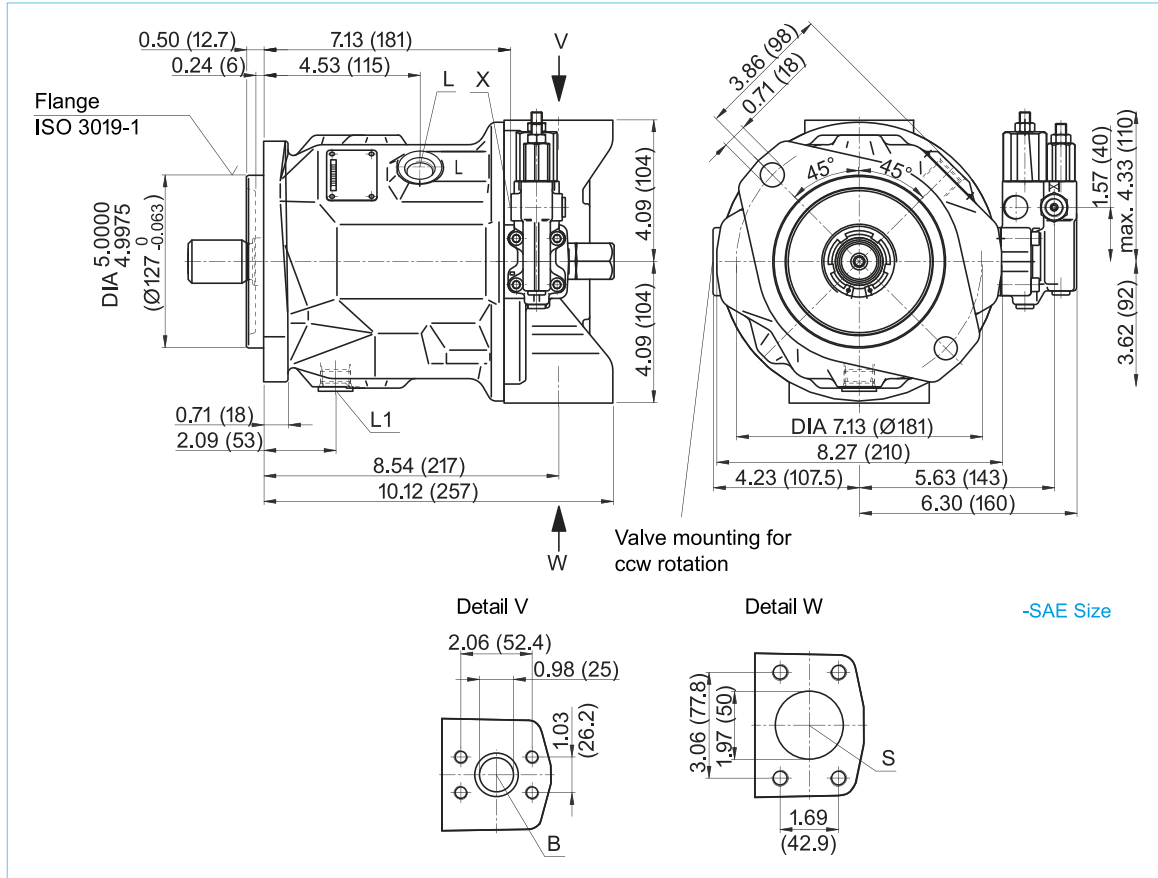

Before finalizing your design request a certified installation drawing. Dimensions in inches and (mm).

Ports

Designation	Port for	Standard	Size ¹⁾	Maximum pressure[psi(bar)] ²⁾	State
B	Service line, fastening thread	SAE J518 ASME B1.1	1 in 3/8-16 UNC-2B; 0.71 (18) deep	5100(350)	O
S	Suction line, fastening thread	SAE J518 ASME B1.1	2 in 1/2-13 UNC-2B; 0.87 (22) deep	145(10)	O
L	Case drain fluid	ISO 11926 ³⁾	7/8-14 UNF-2B; 0.55 (14) deep	30(2)	O ⁴⁾
L1	Case drain fluid	ISO 11926 ³⁾	7/8-14 UNF-2B; 0.55 (14) deep	30(2)	X ⁴⁾
X	Pilot pressure	ISO 11926 ³⁾	7/16-20 UNF-2B; 0.45 (12) deep	5100(350)	O
X	Pilot press. with DG-control	DIN ISO 228 ³⁾	G 1/4 in	5100(350)	O

- 1) For the maximum tightening torques the general instructions on page 51 must be observed.
- 2) Depending on the application, short-term pressure spikes can occur. Keep this in mind when selecting measuring equipment and fittings. Pressure values in bar absolute.
- 3) The spot face can be deeper than as specified in the standard.
- 4) Depending on the installation position, L or L1 must be connected (the following page 49, please check assembling instruction.)
 O = Must be connected (plugged on delivery)
 X = Plugged (in normal operation)

HYDRAULIC PUMP

HSP-10VO

ISO - SAE SIZE DIMENSIONS SIZE 7I

Drive shaft

S
Splined shaft 1 1/4 in
14T 12/24DP ¹⁾ (SAE J744)

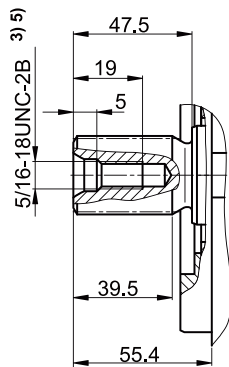

-ISO Size

R
Splined shaft 1 1/4 in
14T 12/24DP ¹⁾²⁾ (SAE J744)

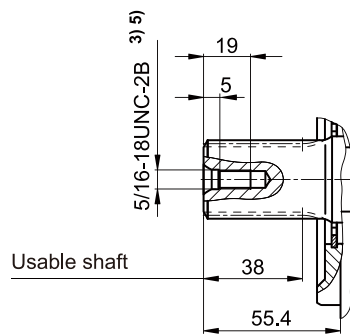

-ISO Size

P
Parallel shaft key
DIN 6885 · A10x8x45

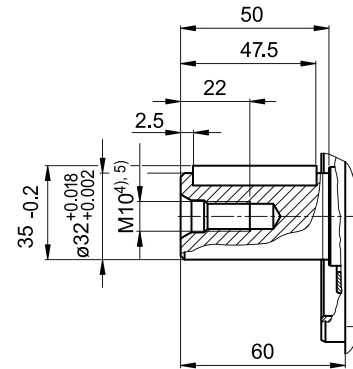

-ISO Size

K
Parallel shaft key
ISO 3019-1, 32-1

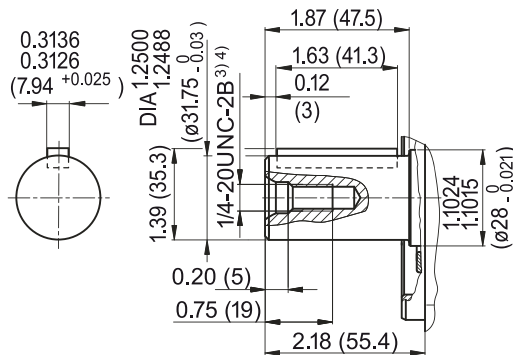

-SAE Size

W
Splined shaft 1 in 15T 16/32 DP
SAE J744- 25-4 (B-B) ⁶⁾

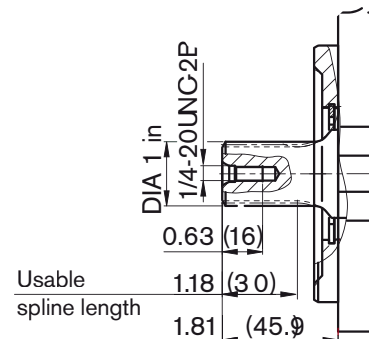

Before finalizing your design request a certified installation drawing. Dimensions in (mm).

- ¹⁾ ANSI B92.1a, 30° pressure angle, flat root, side fit, tolerance class 5
- ²⁾ Splines according to ANSI B92.1a, run out of spline is a deviation from standard
- ³⁾ Thread according to ASME B1.1
- ⁴⁾ Thread according to DIN 13
- ⁵⁾ For the maximum tightening torques the general instructions on page 51 must be observed.
- ⁶⁾ ANSI B92.1a-1976, 30° pressure angle, flat root side fit, flank centering, tolerance class 5

HYDRAULIC PUMP

HSP-10VO

ISO SIZE

DIMENSIONS SIZE 7I

DFLR

Pressure, flow and power control

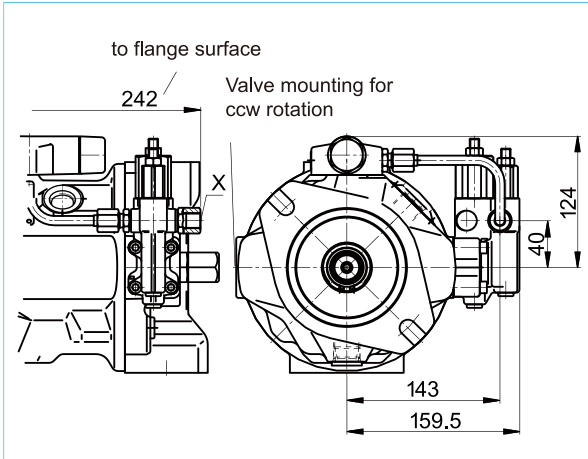

DR

Pressure control

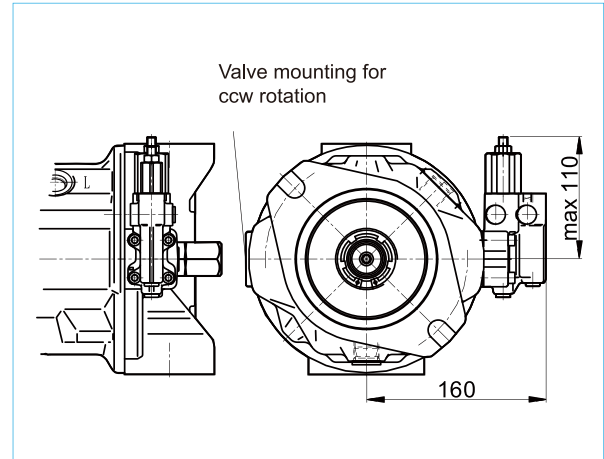

DRG

Pressure control, remotely operated

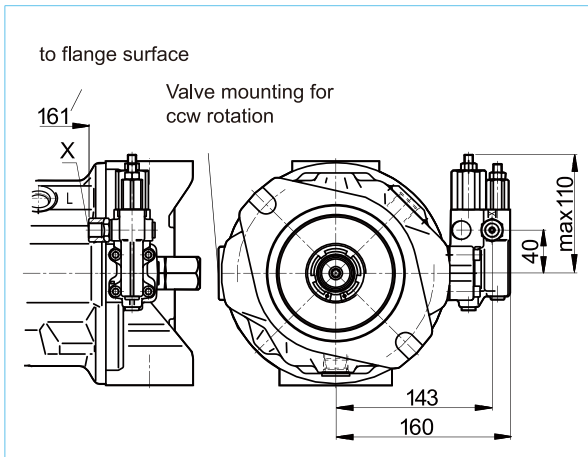

DFR/DFR1

Pressure control, with flow control

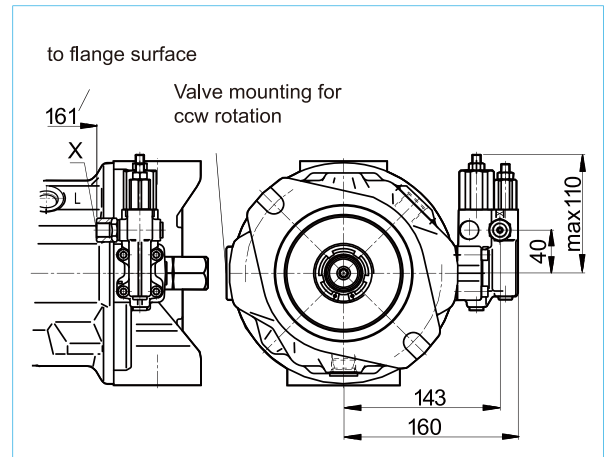

Before finalizing your design request a certified installation drawing. Dimensions in (mm).

HYDRAULIC PUMP

HSP-10VO

ISO SIZE

DIMENSIONS SIZE 100

DFR/DFR1 – Pressure and flow control, hydraulic

Clockwise rotation

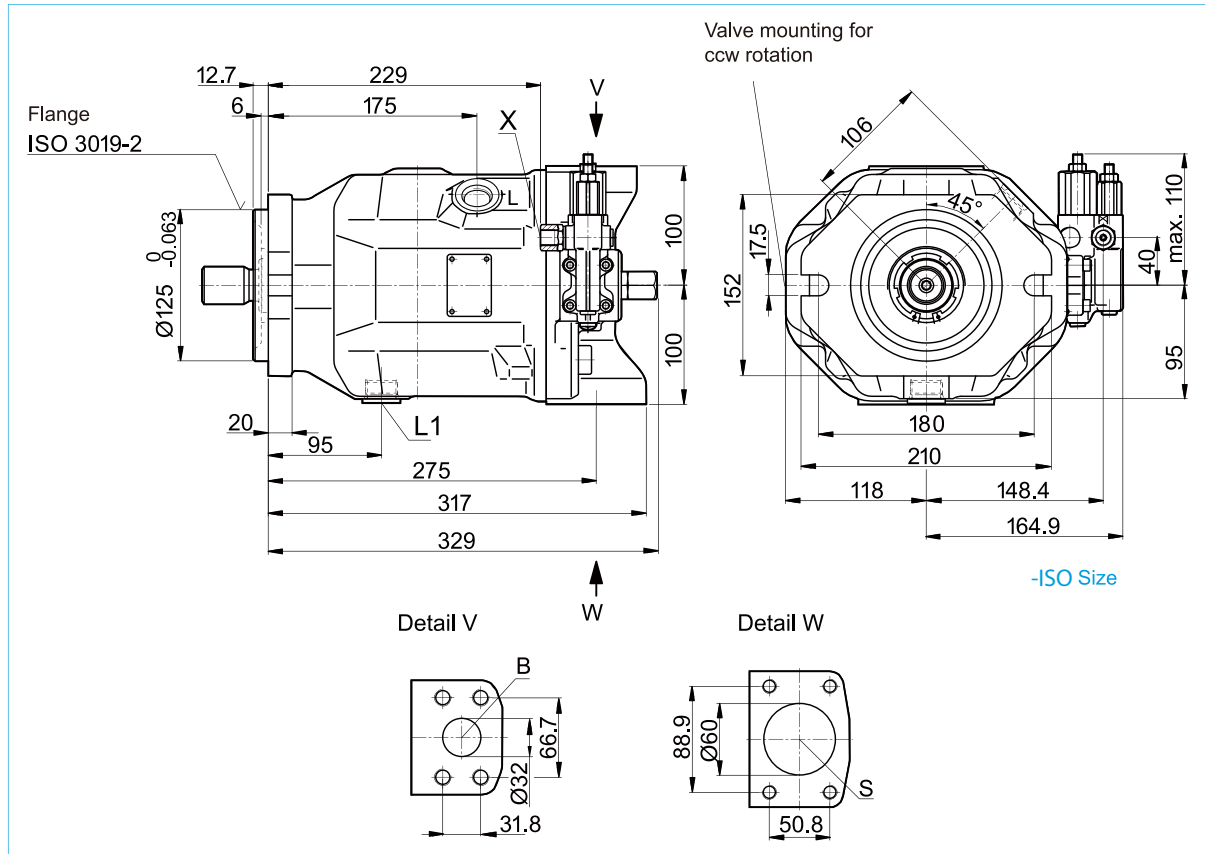

Before finalizing your design request a certified installation drawing. Dimensions in (mm).

Ports

Designation	Port for	Standard	Size ¹⁾	Maximum pressure[psi(bar)] ²⁾	State
B	Service line, fastening thread	SAE J518 ³⁾ DIN 13	1 1/4 in M14 x 2 : 19 (deep)	5100(350)	O
S	Suction line, fastening thread	SAE J518 ³⁾ DIN 13	2 1/2in M12 x 1.75 : 17 (deep)	145(10)	O
L	Case drain fluid	DIN 3852 ⁴⁾	M27 x 2 : 16 (deep)	30(2)	O ⁵⁾
L ₁	Case drain fluid	DIN 3852 ⁴⁾	M27 x 2 : 16 (deep)	30(2)	X ⁵⁾
X	Pilot pressure	DIN 3852 ⁴⁾	M14 x 1.5 : 12 (deep)	5100(350)	O
X	Pilot press. with DG-control	DIN ISO 228 ⁴⁾	G 1/4 in	5100(350)	O

- 1) For the maximum tightening torques the general instructions on page 51 must be observed.
- 2) Depending on the application, short-term pressure spikes can occur. Keep this in mind when selecting measuring equipment and fittings. Pressure values in bar absolute.
- 3) The dimension follow SAE J518, Metric fastening thread and standard thread are different.
- 4) The spot face can be deeper than as specified in the standard
- 5) Depending on the installation position, L or L₁ must be connected (the following page 49, please check assembling instruction.)
 O = Must be connected (plugged on delivery)
 X = Plugged (in normal operation)

HYDRAULIC PUMP

HSP-10VO

SAE SIZE

DIMENSIONS SIZE 100

DFR/DFR1 – Pressure and flow control, hydraulic

Clockwise rotation

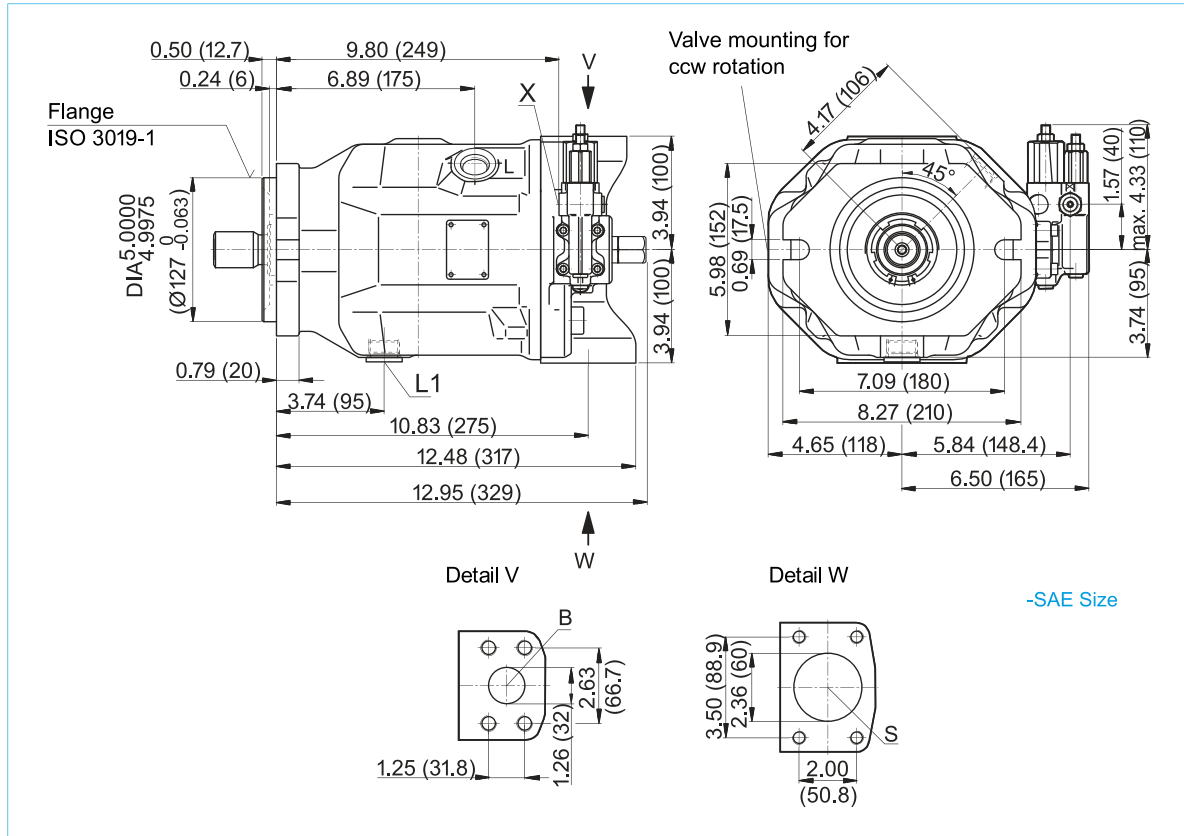

-SAE Size

Before finalizing your design request a certified installation drawing. Dimensions in inches and (mm).

Ports

Designation	Port for	Standard	Size ¹⁾	Maximum pressure[psi(bar)] ²⁾	State
B	Service line, fastening thread	SAE J518 ASME B1.1	1 1/4 in 1/2-13 UNC-2B; 0.75 (19) deep	5100(350)	O
S	Suction line, fastening thread	SAE J518 ASME B1.1	2 1/2 in 1/2-13 UNC-2B; 1.06 (27) deep	145(10)	O
L	Case drain fluid	ISO 11926 ³⁾	1 1/16-12 UNF-2B; 0.63 (16) deep 30(2)		O ⁴⁾
L1	Case drain fluid	ISO 11926 ³⁾	1 1/16-12 UNF-2B; 0.63 (16) deep 30(2)		X ⁴⁾
X	Pilot pressure	ISO 11926 ³⁾	7/16-20 UNF-2B; 0.45 (12) deep	5100(350)	O
X	Pilot press. with DG-control	DIN ISO 228 ³⁾	G 1/4 in	5100(350)	O

- 1) For the maximum tightening torques the general instructions on page 51 must be observed.
- 2) Depending on the application, short-term pressure spikes can occur. Keep this in mind when selecting measuring equipment and fittings. Pressure values in bar absolute.
- 3) The spot face can be deeper than as specified in the standard.
- 4) Depending on the installation position, L or L1 must be connected (the following page 49, please check assembling instruction.)
 O = Must be connected (plugged on delivery)
 X = Plugged (in normal operation)

HYDRAULIC PUMP

HSP-10VO

ISO - SAE SIZE DIMENSIONS SIZE 100

Drive shaft

S Splined shaft 1 1/2 in
17T 12/24DP¹⁾ (SAE J744)

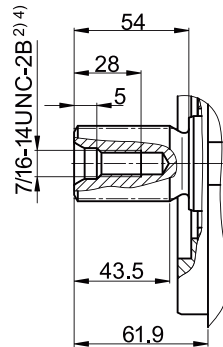

-ISO Size

P Parallel shaft key
DIN 6885 · A12x8x68

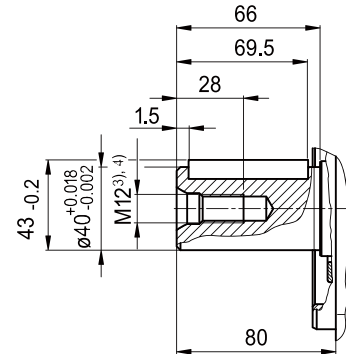

-ISO Size

K Parallel shaft key
ISO 3019-1, 38-1

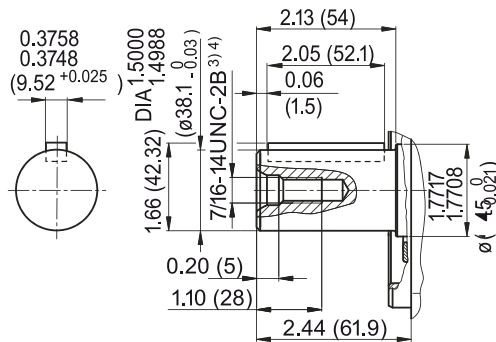

-SAE Size

U Splined shaft 1 1/4 in 14T 12/24 DP1) SAE
J744 - 32-4 (C)⁶⁾

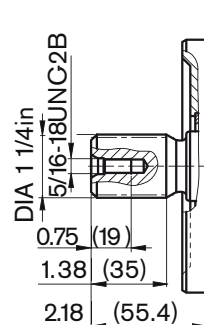

-SAE Size

W Splined shaft 1 1/4 in 14T 12/24 DP1) SAE
J744 - 32-4 (C)⁶⁾

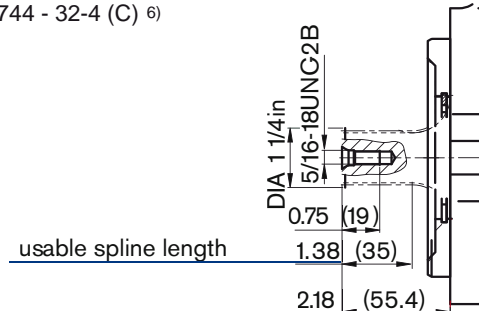

-SAE Size

Before finalizing your design request a certified installation drawing. Dimensions in (mm).

- 1) ANSI B92.1a, 30° pressure angle, flat root, side fit, tolerance class 5
- 2) Splines according to ANSI B92.1a, run out of spline is a deviation from standard
- 3) Thread according to ASME B1.1
- 4) Thread according to DIN 13
- 5) For the maximum tightening torques the general instructions on page 51 must be observed.
- 6) ANSI B92.1a-1976, 30° pressure angle, flat root side fit, flank centering, tolerance class 5

HYDRAULIC PUMP

HSP-10VO

ISO SIZE

DIMENSIONS SIZE 100

DFLR

Pressure, flow and power control

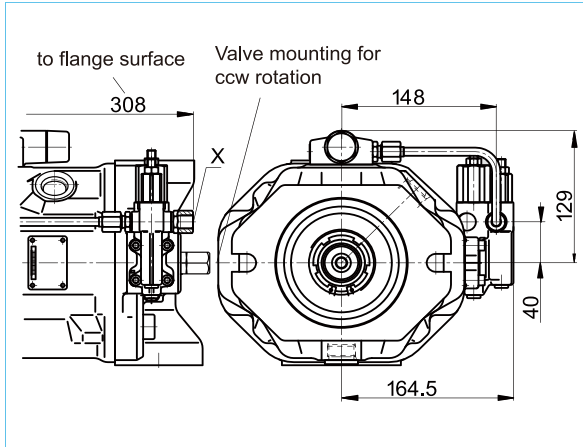

DR

Pressure control

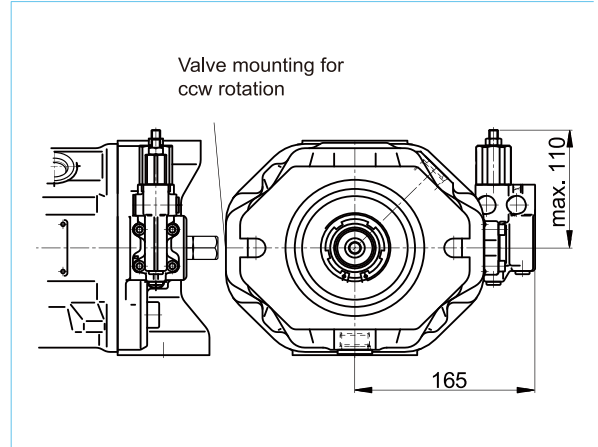

DRG

Pressure control, remotely operated

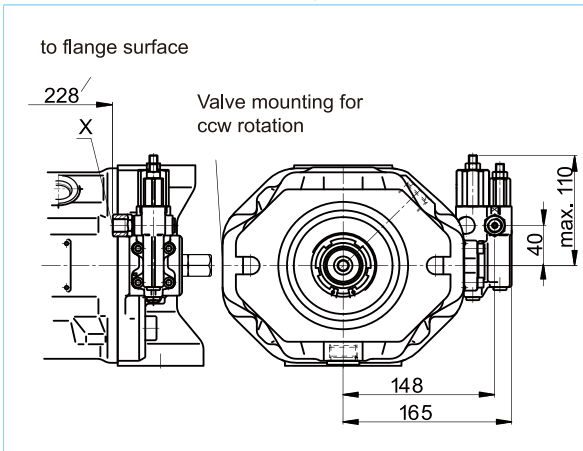

DFR/DFR1

Pressure control, with flow control

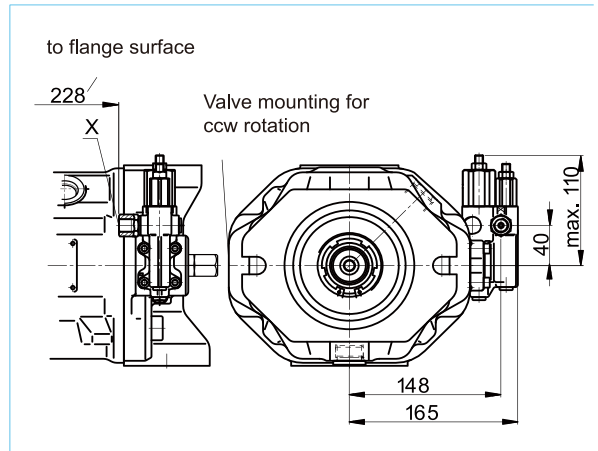

Before finalizing your design request a certified installation drawing. Dimensions in (mm).

HYDRAULIC PUMP

HSP-10VO

ISO SIZE

DIMENSIONS SIZE I40

DFR/DFR1 — Pressure and flow control, hydraulic

Clockwise rotation

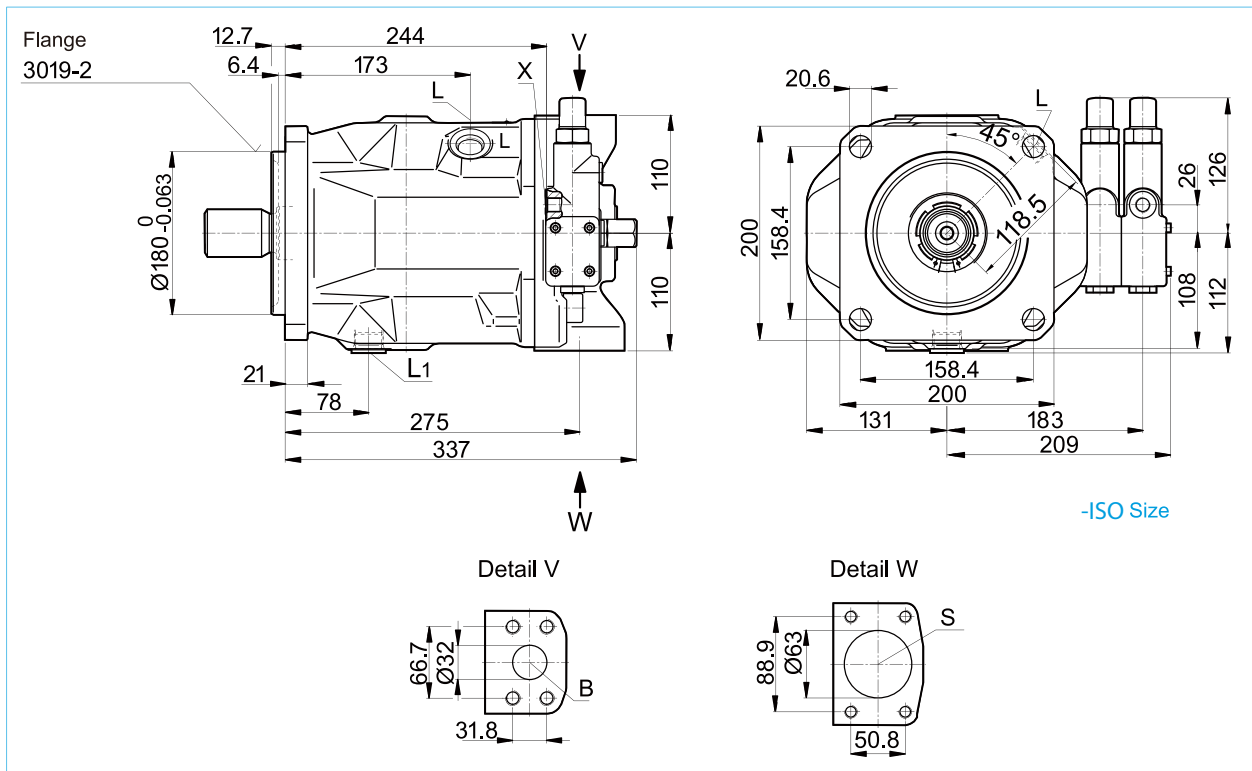

-ISO Size

Before finalizing your design request a certified installation drawing.
Dimensions in (mm).

Ports

Designation	Port for	Standard	Size ¹⁾	Maximum pressure[psi(bar)] ²⁾	State
B	Service line, fastening thread	SAE J518 ³⁾ DIN 13	1 1/4 in M14 x 2 : 19 (deep)	5100(350)	O
S	Suction line, fastening thread	SAE J518 ³⁾ DIN 13	2 1/2 in M12 x 1.75 : 17 (deep)	145(10)	O
L	Case drain fluid	DIN 3852 ⁴⁾	M27 x 2 : 16 (deep)	30(2)	O ⁵⁾
L ₁	Case drain fluid	DIN 3852 ⁴⁾	M27 x 2 : 16 (deep)	30(2)	X ⁵⁾
X	Pilot pressure	DIN 3852 ⁴⁾	M14 x 1.5 : 12 (deep)	5100(350)	O
X	Pilot press. with DG-control	DIN 3852 ⁴⁾	M14 x 1.5 : 12 (deep)	5100(350)	O
M _H	Gauge port, high pressure	DIN 3852	M14 x 1.5 , 12 deep	5100(350)	X

- 1) For the maximum tightening torques the general instructions on page 51 must be observed.
- 2) Depending on the application, short-term pressure spikes can occur. Keep this in mind when selecting measuring equipment and fittings. Pressure values in bar absolute.
- 3) The dimension follow SAE J518, Metric fastening thread and standard thread are different.
- 4) The spot face can be deeper than as specified in the standard
- 5) Depending on the installation position, L or L₁ must be connected (the following page 49, please check assembling instruction.)
O = Must be connected (plugged on delivery)
X = Plugged (in normal operation)

HYDRAULIC PUMP

HSP-10VO

SAE SIZE

DIMENSIONS SIZE 140

DFR/DFR1 — Pressure and flow control, hydraulic

Clockwise rotation

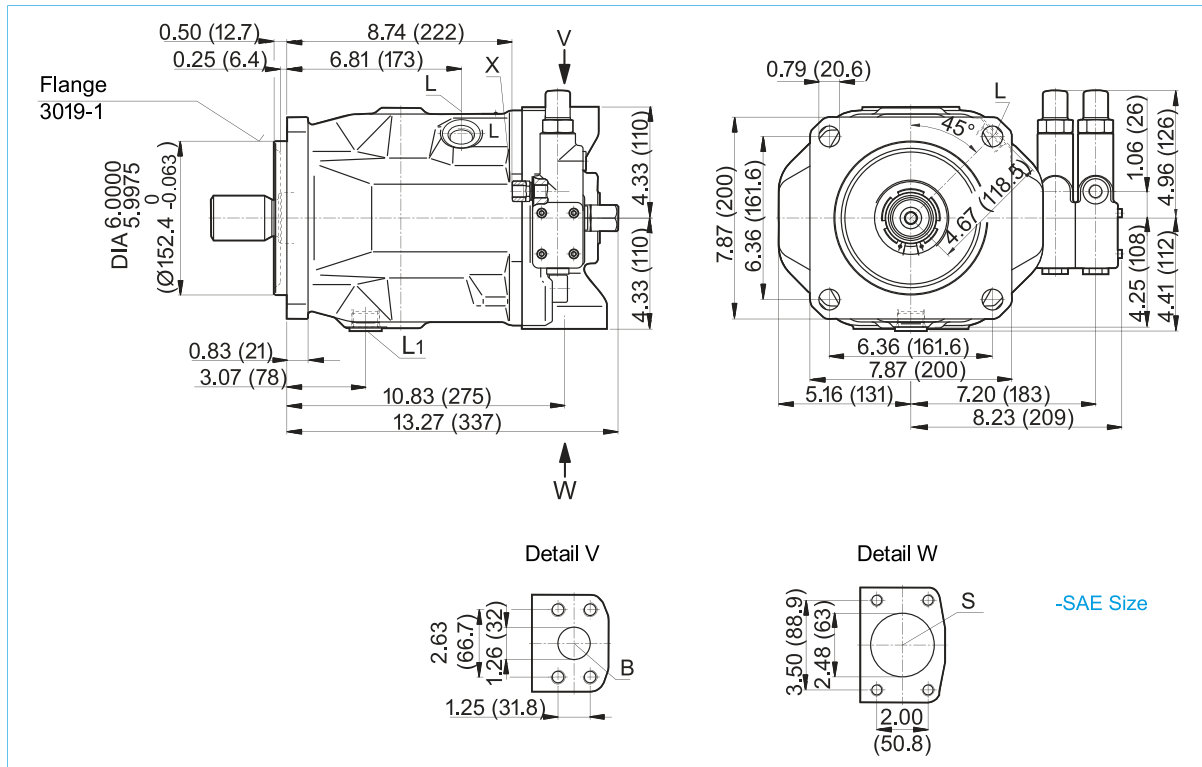

Before finalizing your design request a certified installation drawing.
Dimensions in inches and (mm).

Ports

Designation	Port for	Standard	Size ¹⁾	Maximum pressure[psi(bar)] ²⁾	State
B	Service line, fastening thread	SAE J518 ASME B1.1	1 1/4 in 1/2-13 UNC-2B; 0.94 (24) deep	5100(350)	O
S	Suction line, fastening thread	SAE J518 ASME B1.1	2 1/2 in 1/2-13 UNC-2B; 0.94 (24) deep	145(10)	O
L	Case drain fluid	ISO 11926 ³⁾	1 1/16-12 UNF-2B; 0.63 (16) deep 30(2)		O ⁴⁾
L1	Case drain fluid	ISO 11926 ³⁾	1 1/16-12 UNF-2B; 0.63 (16) deep 30(2)		X ⁴⁾
X	Pilot pressure	ISO 11926 ³⁾	9/16-18 UNF-2B; 0.51 (13) deep	5100(350)	O
X	Pilot press. with DG-control	DIN ISO 228 ³⁾	M14 x 1.5; 0.47 (12) deep	5100(350)	O
M _H	Gauge port, high pressure	DIN 3852	M14 x 1.5, 0.47 (12) deep	5100(350)	X

- 1) For the maximum tightening torques the general instructions on page 51 must be observed.
- 2) Depending on the application, short-term pressure spikes can occur. Keep this in mind when selecting measuring equipment and fittings. Pressure values in bar absolute.
- 3) The spot face can be deeper than as specified in the standard.
- 4) Depending on the installation position, L or L1 must be connected (the following page 49, please check assembling instruction.)
O = Must be connected (plugged on delivery)
X = Plugged (in normal operation)

HYDRAULIC PUMP

HSP-10VO

ISO - SAE SIZE DIMENSIONS SIZE I40

Drive

S Splined shaft 1 3/4 in
13T 8/16DP ¹⁾ (SAE J744)

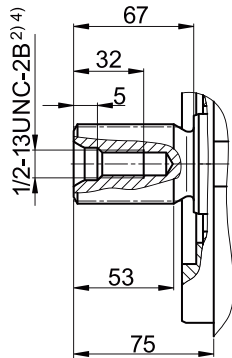

-ISO Size

P Parallel shaft key
DIN 6885 · A14x9x80

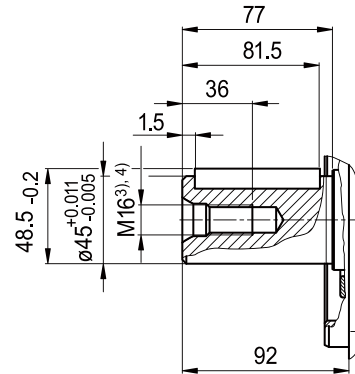

-ISO Size

K

Parallel shaft key
ISO 3019-1, 44-1

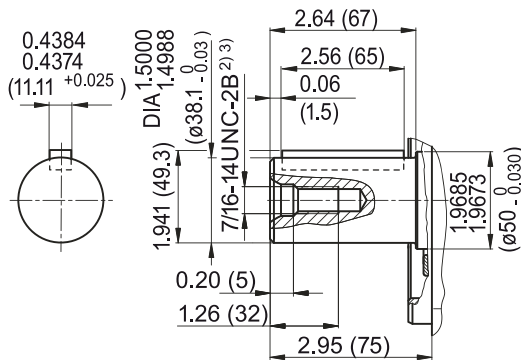

-SAE Size

Before finalizing your design request a certified installation drawing. Dimensions in (mm).

- 1) ANSI B92.1a, 30° pressure angle, flat root, side fit, tolerance class 5
- 2) Thread according to ASME B1.1
- 3) Thread according to DIN 13
- 4) For the maximum tightening torques the general instructions on page 51 must be observed.

HYDRAULIC PUMP

HSP-10VO

ISO SIZE

DIMENSIONS SIZE 140

DFLR

Pressure, flow and power control

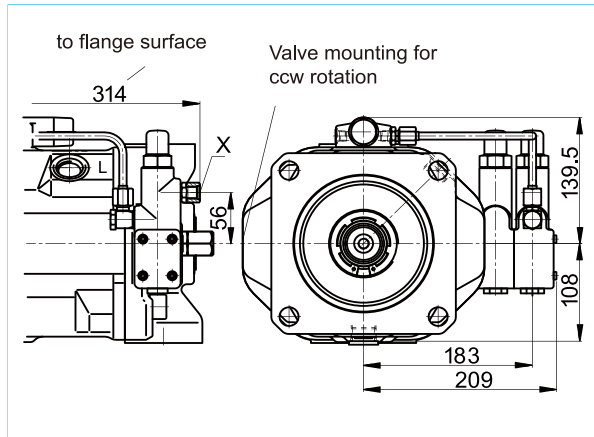

DR

Pressure control

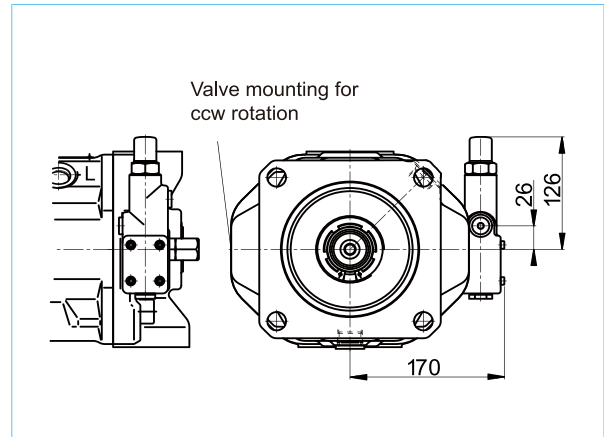

DRG

Pressure control, remotely operated

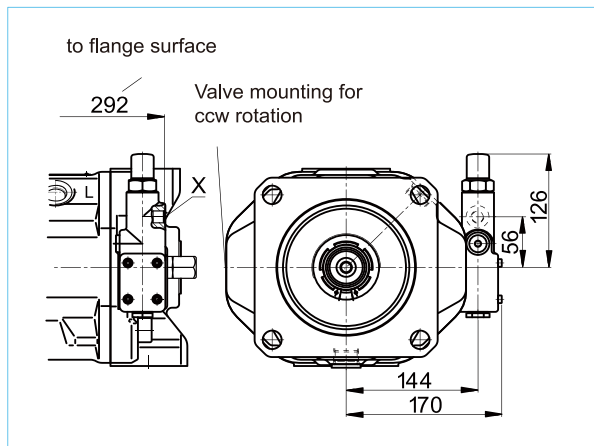

DFR/DFR1

Flow control, hydraulic

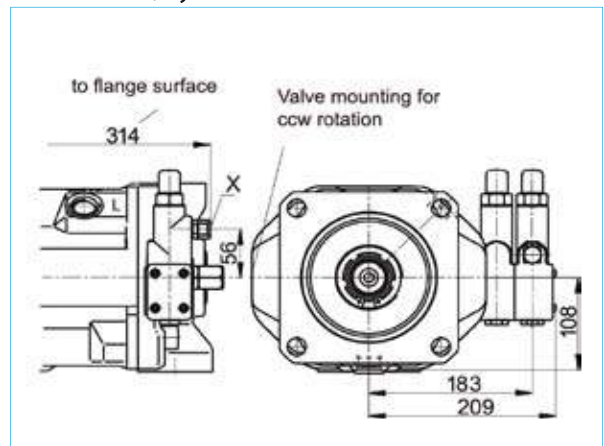

Before finalizing your design request a certified installation drawing. Dimensions in (mm).

HYDRAULIC PUMP

HSP-10VO

ISO SIZE

DIMENSIONS THROUGH DRIVE

K01 flange ISO 3019-1 (SAE J744 - 82-2 (A))
Coupling for splined shaft according to ANSI B92.1a-1996

Before finalizing your design request a certified installation drawing.
Dimensions in (mm).

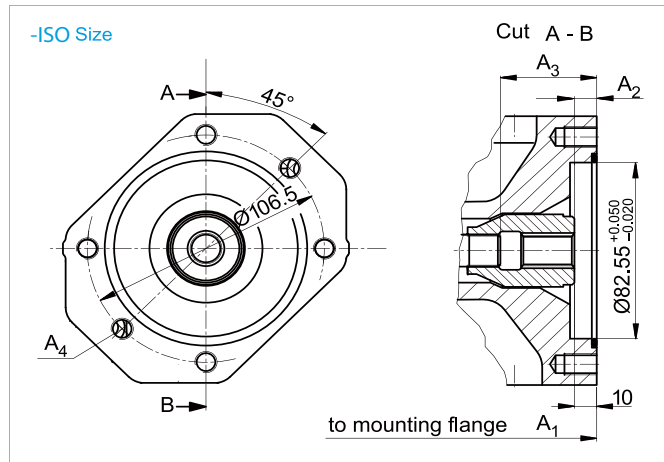

5/8 in 9T 16/32 DP¹⁾ (SAE J744 - 16-4 (A))

Inch (mm)

NG	A ₁	A ₂	A ₃	A ₄ ²⁾
18	7.16 (182)	0.39 (10)	1.70 (43.3)	M10 x 1.5, 0.57(14.5) deep
28	8.03 (204)	0.39 (10)	1.33 (33.7)	M10 x 1.5, 0.62(16) deep
45	9.02 (229)	0.42 (10.7)	2.10 (53.4)	M10 x 1.5, 0.62(16) deep
71	10.51 (267)	0.46 (11.8)	2.41 (61.3)	M10 x 1.5, 0.78(20) deep
100	13.31 (338)	0.41 (10.5)	2.56 (65)	M10 x 1.5, 0.62(16) deep
140	13.78 (350)	0.43 (10.8)	3.04 (77.3)	M10 x 1.5, 0.62(16) deep

K52 flange ISO 3019-2 (SAE J744 - 82-2 (A))
Coupling for splined shaft according to ANSI B92.1a-1996

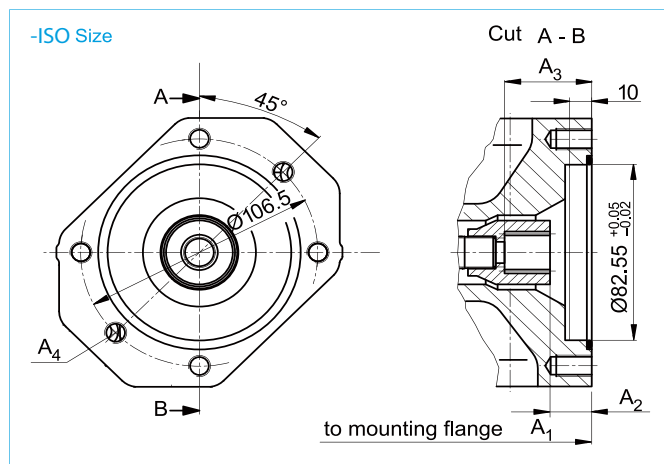

3/4 in 11T 16/32 DP¹⁾(SAE J744 - 19-4 (A-B))

Inch (mm)

NG	A ₁	A ₂	A ₃	A ₄ ²⁾
18	7.16 (182)	0.74 (18.8)	1.52 (38.7)	M10 x 1.5, 0.57(14.5) deep
28	8.03 (204)	0.74 (18.8)	1.52 (38.7)	M10 x 1.5, 0.62(16) deep
45	9.02 (229)	0.744 (18.9)	1.52 (38.7)	M10 x 1.5, 0.62(16) deep
71	10.51 (267)	0.84 (21.3)	1.63 (41.4)	M10 x 1.5, 0.78(20) deep
100	13.31 (338)	0.75 (19)	1.53 (38.9)	M10 x 1.5, 0.62(16) deep
140	13.78 (350)	0.744 (18.9)	1.52 (38.6)	M10 x 1.5, 0.62(16) deep

K68 flange ISO 3019-2 (SAE J744 - 101-2 (B))
Coupling for splined shaft according to ANSI B92.1a-1996

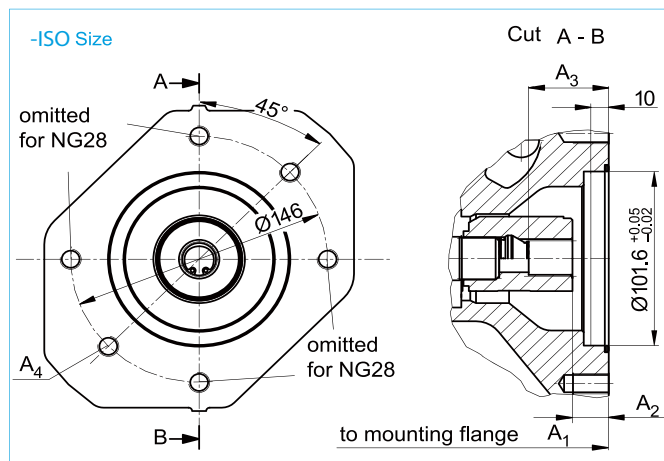

7/8 in 13T 16/32 DP¹⁾ (SAE J744 - 22-4 (B))

Inch (mm)

NG	A ₁	A ₂	A ₃	A ₄ ²⁾
28	8.03 (204)	0.70 (17.8)	1.64 (41.7)	M12x 1.75, continuous
45	9.02 (229)	0.704 (17.9)	1.64 (41.7)	M12 x 1.75, 0.71(18) deep
71	10.51 (267)	0.80 (20.3)	1.74 (44.1)	M12 x 1.75, 0.78(20) deep
100	13.31 (338)	0.71 (18)	1.65 (41.9)	M12 x 1.75, 0.78(20) deep
140	13.78 (350)	0.70 (17.8)	1.64 (41.6)	M12 x 1.75, 0.78(20) deep

1) 30° pressure angle, flat root, side fit, tolerance class 5

2) Thread according to DIN 13, observe the general instructions on page 51 for the maximum tightening torques.

HYDRAULIC PUMP

HSP-10VO

ISO SIZE

DIMENSIONS THROUGH DRIVE

K04 flange ISO 3019-2 (SAE J744 - 101-2 (B))
Coupling for splined shaft according to ANSI B92.1a-1996

Before finalizing your design request a certified installation drawing.
Dimensions in (mm).

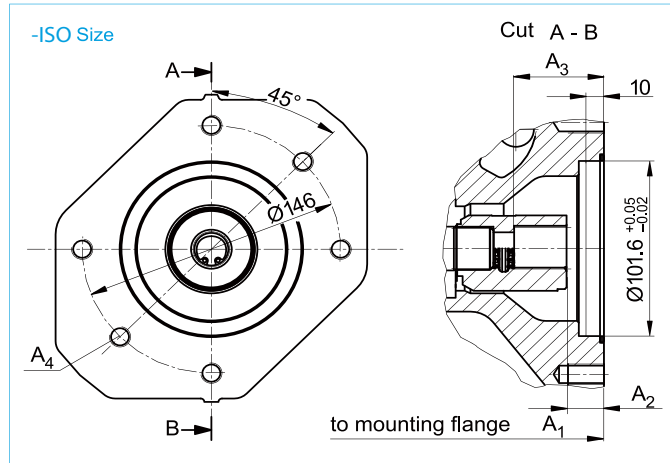

1 in 15T 16/32 DP¹⁾(SAE J744 - 25-4 (B-B))
Inch (mm)

NG	A ₁	A ₂	A ₃	A ₄ ²⁾
45	9.02 (229)	0.724 (18.4)	1.84 (46.7)	M12x 1.75, 0.71(18) deep
71	10.51 (267)	0.82 (20.8)	1.93 (49.1)	M12 x 1.75, 0.78(20) deep
100	13.31 (338)	0.716 (18.2)	1.83 (46.6)	M12 x 1.75, 0.78(20) deep
140	13.78 (350)	0.72 (18.3)	1.81 (45.9)	M12 x 1.75, 0.78(20) deep

K07 flange ISO 3019-2 (SAE J744 - 127-2 (C))
Coupling for splined shaft according to ANSI B92.1a-1996

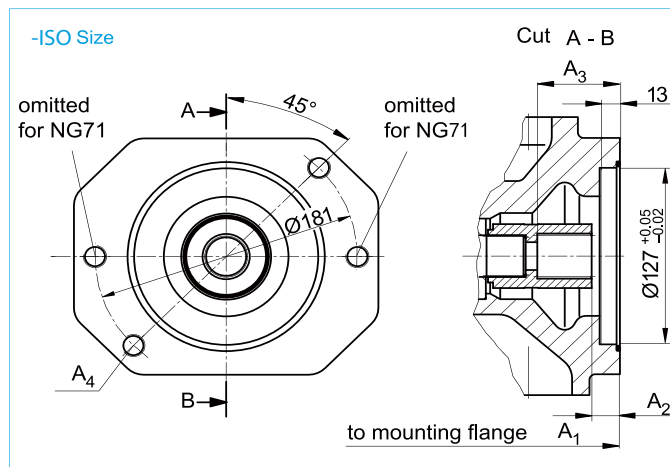

1 1/4 in 14T 12/24 DP¹⁾(SAE J744 - 32-4 (C))
Inch (mm)

NG	A ₁	A ₂	A ₃	A ₄ ²⁾
71	10.51 (267)	0.86 (21.8)	2.31 (58.6)	M16 x 2, continuous
100	13.31 (338)	0.77 (19.5)	2.22 (56.4)	M6 x 2, continuous
140	13.78 (350)	0.76 (19.3)	2.21 (56.1)	M16 x 2, 0.94(24) deep

K24 flange ISO 3019-2 (SAE J744 - 127-2 (C))
Coupling for splined shaft according to ANSI B92.1a-1996

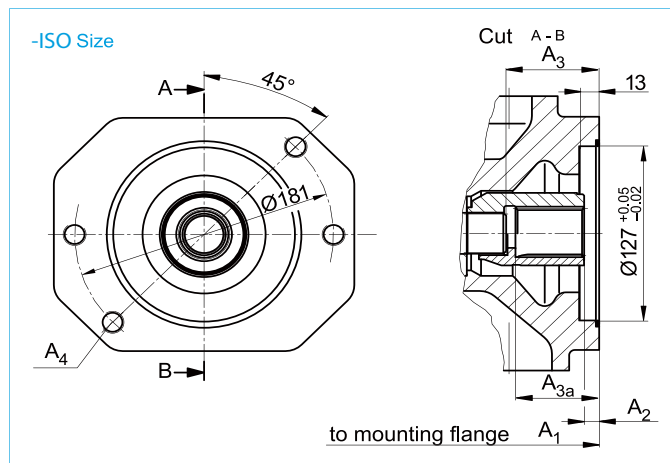

1 1/2 in 17T 12/24 DP¹⁾(SAE J744 - 38-4 (C-C))
Inch (mm)

NG	A ₁	A ₂	A ₃ ³⁾	A _{3a} ⁴⁾	A ₄ ²⁾
100	13.31 (338)	0.41 (10.5)	2.56 (65)	—	M16 x 2, continuous
140	13.78 (350)	0.42 (10.8)	2.95 (75)	—	M16 x 2, 0.94 (24)deep
	13.78 (350)	0.40 (10.3)	—	2.72 (69.1)	M16 x 2, 0.94 (24)deep

- 3) Coupling without stop
- 4) Coupling with stop

1) 30° pressure angle, flat root, side fit, tolerance class 5

2) Thread according to DIN 13, observe the general instructions on page 51 for the maximum tightening torques.

HYDRAULIC PUMP

HSP-10VO

ISO SIZE

DIMENSIONS THROUGH DRIVE

K17 flange ISO 3019-2 (SAE J744 - 152-4 (A))
Coupling for splined shaft according to ANSI B92.1a-1996

Before finalizing your design request a certified installation drawing.
Dimensions in (mm).

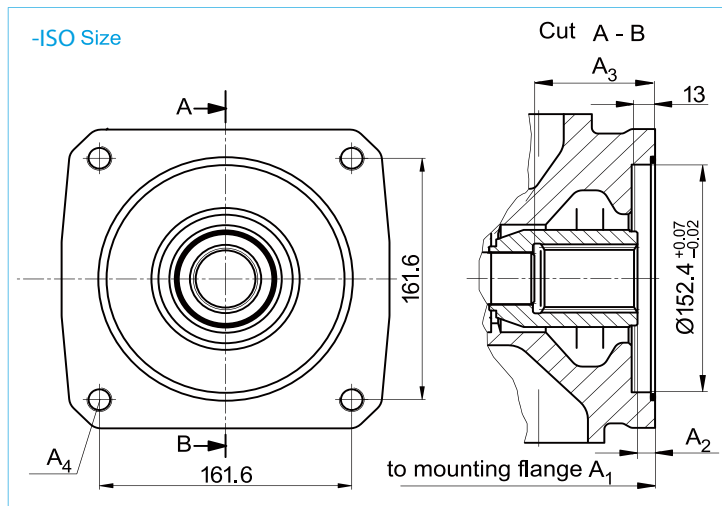

1 3/4 in 13T 8/16 DP ¹⁾(SAE J744 - 44-4 (D))

Inch (mm)

NG	A ₁	A ₂	A ₃	A ₄ ²⁾
140	13.78 (350)	0.43 (11)	3.04 (77.3)	M6 x 2, continuous

K57 flange for mounting R4 radial piston pump of metric 4 hole flange coupling for metric parallel shaft key.

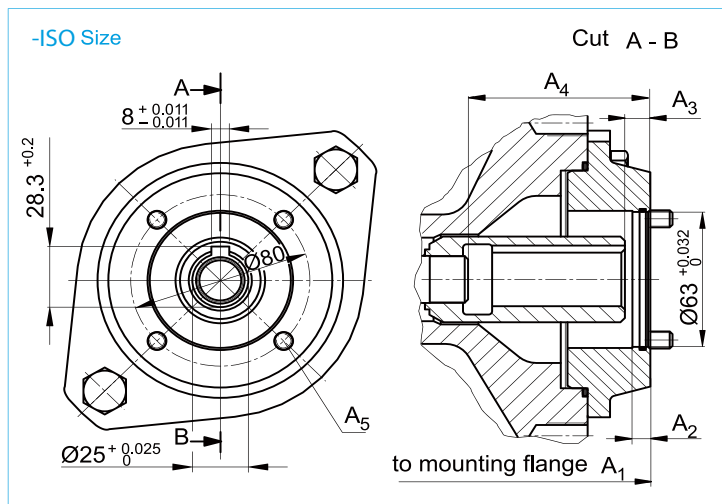

mm

NG	A ₁	A ₂	A ₃	A ₄	A ₅ ³⁾
28	232	8	10.6	58.4	M8
45	257	8	11	81	M8
71	283	8	12.5	77	M10
100	354	8	10.5	81	M10
140	366	8	11	93	M8

- 1) 30° pressure angle, flat root, side fit, tolerance class 5°
- 2) Thread according to DIN 13, observe the general instructions on page 51 for the maximum tightening torques.
- 3) Screws for mounting the radial piston motor are included in the delivery contents.

HYDRAULIC PUMP

HSP-10VO

ISO SIZE

DIMENSIONS THROUGH DRIVE

KB2 flange ISO 3019-2 - 80A2SW
Coupling for splined shaft according to ANSI B92.1a-1996

Before finalizing your design request a certified installation drawing. Dimensions in (mm).

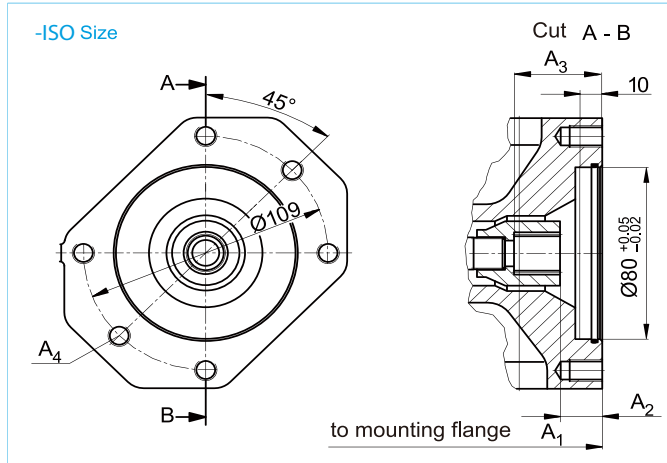

3/4 in 11T 16/32 DP ¹⁾ (SAE J744 - 19-4 (A-B))
mm

NG	A ₁	A ₂	A ₃	A ₄ ²⁾
18	182	18.8	38.7	M10 x 1.5 · 14.5 deep
28	204	18.8	38.7	M10 x 1.5 · 16 deep
45	229	18.9	38.7	M10 x 1.5 · 16 deep
71	267	21.3	41.4	M10 x 1.5 · 20 deep
100	338	19	38.9	M10 x 1.5 · 20 deep
140	350	18.9	38.6	M10 x 1.5 · 20 deep

KB3 flange ISO 3019-2 - 100A2SW
Coupling for splined shaft according to ANSI B92.1a-1996

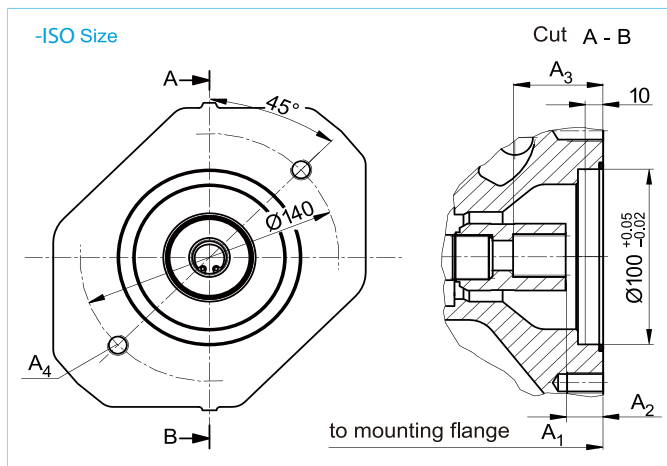

7/8 in 13T 16/32 DP ¹⁾ (SAE J744 - 22-4 (B))
mm

NG	A ₁	A ₂	A ₃	A ₄ ²⁾
28	204	17.8	41.7	M12 x 1.5 · continuous
45	229	17.9	41.7	M12 x 1.5 · continuous
71	267	20.3	44.1	M12 x 1.5 · 20 deep
100	338	18	41.9	M12 x 1.5 · 20 deep
140	350	17.8	41.6	M12 x 1.5 · 20 deep

KB4 flange ISO 3019-2 - 100A2SW
Coupling for splined shaft according to ANSI B92.1a-1996

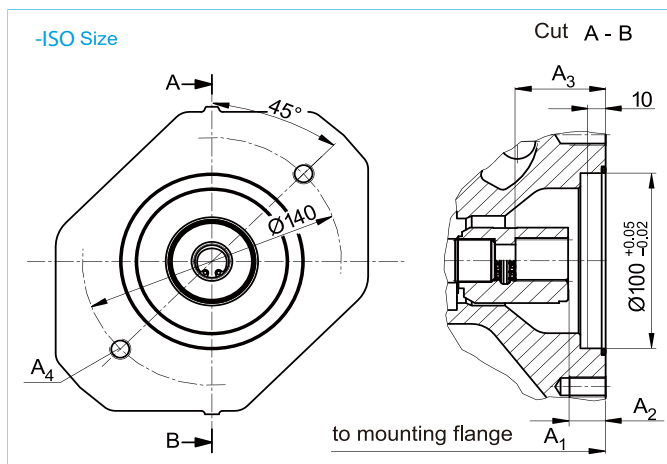

1 in 15T 16/32 DP ¹⁾ (SAE J744 - 25-4 (B-B))
mm

NG	A ₁	A ₂	A ₃	A ₄ ²⁾
45	229	18.4	46.7	M12 x 1.75 · continuous
71	267	20.8	49.1	M12 x 1.75 · 20 deep
100	338	18.2	46.6	M12 x 1.75 · 20 deep
140	350	18.3	45.9	M12 x 1.75 · 20 deep

¹⁾ 30° pressure angle, flat root, side fit, tolerance class 5

²⁾ Thread according to DIN 13, observe the general instructions on page 51 for the maximum tightening torques.

HYDRAULIC PUMP

HSP-10VO

ISO SIZE

DIMENSIONS THROUGH DRIVE

KB5 flange ISO 3019-2 - 125A2SW
Coupling for splined shaft according to ANSI B92.1a-1996

Before finalizing your design request a certified installation drawing.
Dimensions in (mm).

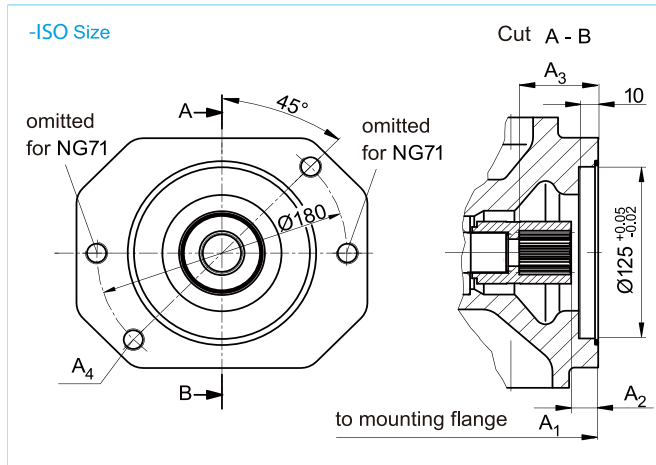

1 1/4 in 14T 12/24 DP ¹⁾ (SAE J744 - 32-4 (C))

mm

NG	A ₁	A ₂	A ₃	A ₄ ²⁾
71	267	21.8	58.6	M16 x 2 , continuous
100	338	19.5	56.4	M16 x 2 , continuous
140	350	19.3	56.1	M16 x 2 , 24 deep

KB6 flange ISO 3019-2 - 125A2SW
Coupling for splined shaft according to ANSI B92.1a-1996

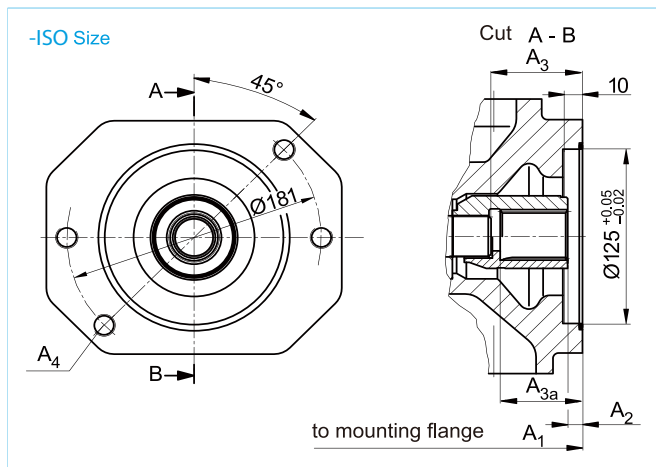

1 1/2 in 17T 12/24 DP ¹⁾ (SAE J744 - 38-4 (C-C))

mm

NG	A ₁	A ₂	A ₃ ³⁾	A _{3a} ⁴⁾	A ₄ ²⁾
100	338	10.5	65	-	M16 x 2 , continuous
140	350	10.8	75	-	M16 x 2 , 24 deep
	350	10.3	-	69.1	M16 x 2 , 24 deep

KB7 flange ISO 3019-2 - 180B4HW
Coupling for splined shaft according to ANSI B92.1a-1996

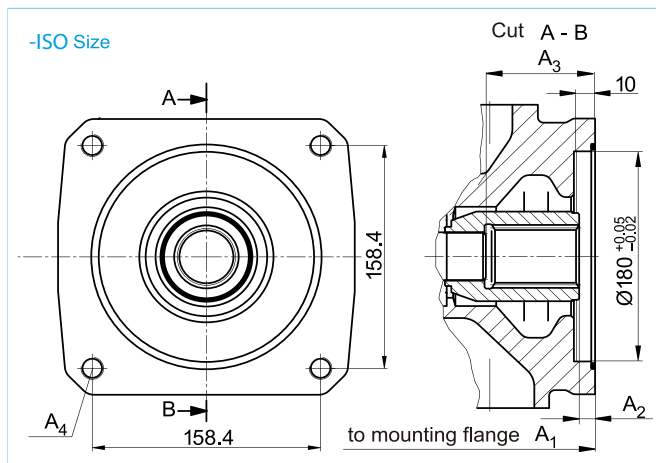

1 3/4 in 13T 8/16 DP ¹⁾ (SAE J744 - 44-4 (D))

mm

NG	A ₁	A ₂	A ₃	A ₄ ²⁾
140	350	11.3	77.3	M16 x 2 , continuous

- 3) Coupling without stop
- 4) Coupling with stop

1) 30° pressure angle, flat root, side fit, tolerance class 5
2) Thread according to DIN 13, observe the general instructions on page 51 for the maximum tightening torques.

HYDRAULIC PUMP

HSP-10VO

SAE SIZE

DIMENSIONS THROUGH DRIVE

K01 flange ISO 3019-1 (SAE J744 - 82-2 (A))
Coupling for splined shaft according to ANSI B92.1a

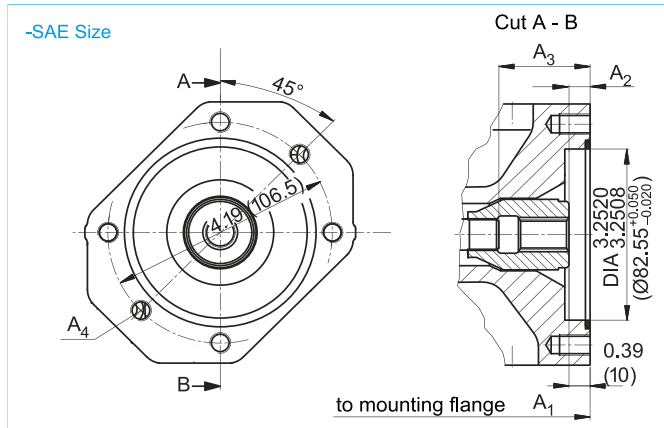

5/8 in 9T 16/32 DP¹⁾(SAE J744 - 16-4 (A))

NG	A ₁	A ₂	A ₃	A ₄ ²⁾
18	7.16 (182)	0.39 (10)	1.70 (43.3)	M10 x 1.5, 0.57 (14.5) deep
28	8.03 (204)	0.39 (10)	1.33 (33.7)	M10 x 1.5, 0.62 (16) deep
45	9.02 (229)	0.42 (10.7)	2.10 (53.4)	M10 x 1.5, 0.62 (16) deep
71	10.51 (267)	0.46 (11.8)	2.41 (61.3)	M10 x 1.5, 0.78 (20) deep
100	13.31 (338)	0.41 (10.5)	2.56 (65)	M10 x 1.5, 0.62 (16) deep
140	13.78 (350)	0.43 (10.8)	3.04 (77.3)	M10 x 1.5, 0.62 (16) deep

K52 flange ISO 3019-1 (SAE J744 - 82-2 (A))
Coupling for splined shaft according to ANSI B92.1a

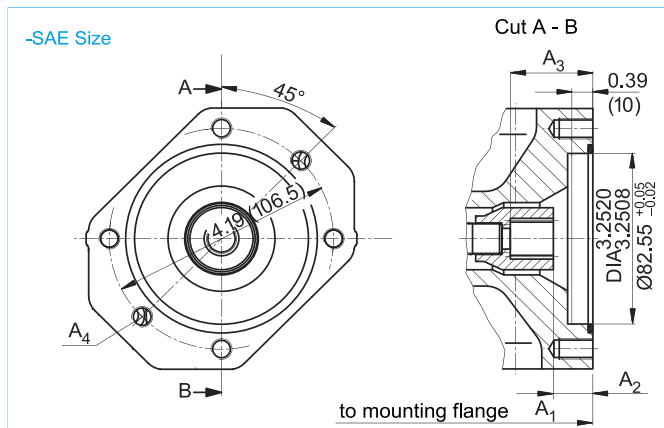

3/4 in 11T 16/32 DP¹⁾(SAE J744 - 19-4 (A-B))

NG	A ₁	A ₂	A ₃	A ₄ ²⁾
18	7.16 (182)	0.74 (18.8)	1.52 (38.7)	M10 x 1.5, 0.57 (14.5) deep
28	8.03 (204)	0.74 (18.8)	1.52 (38.7)	M10 x 1.5, 0.62 (16) deep
45	9.02 (229)	0.744 (18.9)	1.52 (38.7)	M10 x 1.5, 0.62 (16) deep
71	10.51 (267)	0.84 (21.3)	1.63 (41.4)	M10 x 1.5, 0.78 (20) deep
100	13.31 (338)	0.75 (19)	1.53 (38.9)	M10 x 1.5, 0.62 (16) deep
140	13.78 (350)	0.744 (18.9)	1.52 (38.6)	M10 x 1.5, 0.62 (16) deep

K68 flange ISO 3019-1 (SAE J744 - 101-2 (B))
Coupling for splined shaft according to ANSI B92.1a

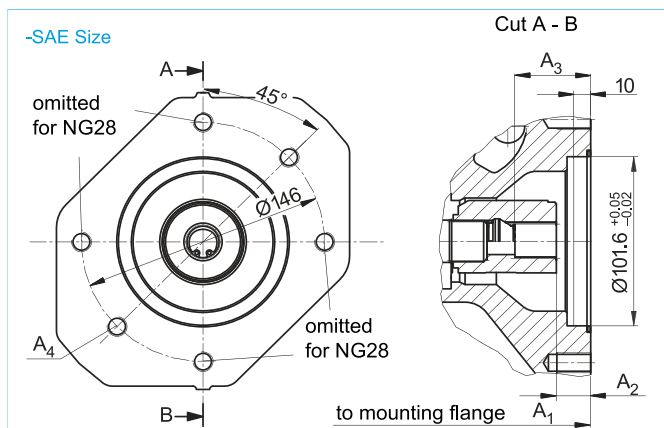

7/8 in 13T 16/32 DP¹⁾(SAE J744 - 22-4 (B))

NG	A ₁	A ₂	A ₃	A ₄ ²⁾
28	8.03 (204)	0.70 (17.8)	1.64 (41.7)	M12 x 1.75, continuous
45	9.02 (229)	0.704 (17.9)	1.64 (41.7)	M12 x 1.75, 0.71 (18) deep
71	10.51 (267)	0.80 (20.3)	1.74 (44.1)	M12 x 1.75, 0.78 (20) deep
100	13.31 (338)	0.71 (18)	1.65 (41.9)	M12 x 1.75, 0.78 (20) deep
140	13.78 (350)	0.70 (17.8)	1.64 (41.6)	M12 x 1.75, 0.78 (20) deep

- 30° pressure angle, flat root, side fit, tolerance class 5
- Thread according to DIN 13, observe the general instructions on page 51 for the maximum tightening torques.

Before finalizing your design request a certified installation drawing.
Dimensions in inches and (mm).

HYDRAULIC PUMP

HSP-10VO

SAE SIZE

DIMENSIONS THROUGH DRIVE

K04 flange ISO 3019-1 (SAE J744 - 101-2 (B))
Coupling for splined shaft according to ANSI B92.1a

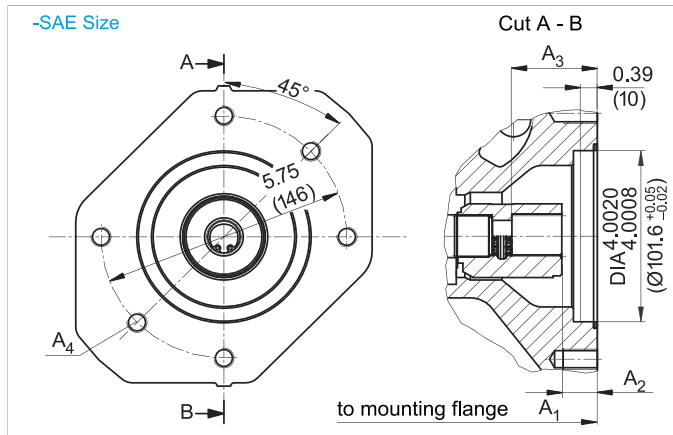

1 in 15T 16/32 DP¹⁾(SAE J744 - 25-4 (B-B))

NG	A ₁	A ₂	A ₃	A ₄ ²⁾
45	9.02 (229)	0.724 (18.4)	1.84 (46.7)	M12 x 1.75, 0.71 (18) deep
71	10.51 (267)	0.82 (20.8)	1.93 (49.1)	M12 x 1.75, 0.78 (20) deep
100	13.31 (338)	0.716 (18.2)	1.83 (46.6)	M12 x 1.75, 0.78 (20) deep
140	13.78 (350)	0.72 (18.3)	1.81 (45.9)	M12 x 1.75, 0.78 (20) deep

K07 flange ISO 3019-1 (SAE J744 - 127-2 (C))
Coupling for splined shaft according to ANSI B92.1a

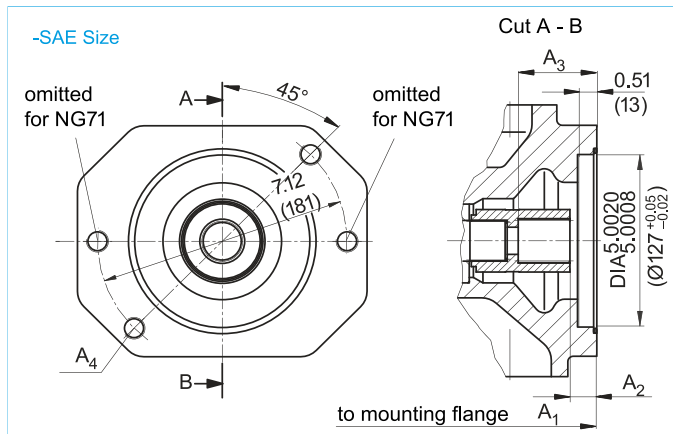

1 1/4 in 14T 12/24 DP¹⁾(SAE J744 - 32-4 (C))

NG	A ₁	A ₂	A ₃	A ₄ ²⁾
71	10.51 (267)	0.86 (21.8)	2.31 (58.6)	M16 x 2, continuous
100	13.31 (338)	0.77 (19.5)	2.22 (56.4)	M16 x 2, continuous
140	13.78 (350)	0.76 (19.3)	2.21 (56.1)	M16 x 2, 0.94 (24) deep

K24 flange ISO 3019-1 (SAE J744 - 127-2 (C))
Coupling for splined shaft according to ANSI B92.1a

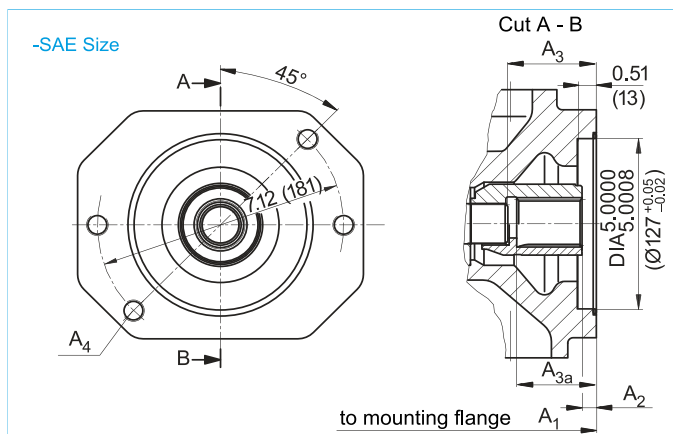

1 1/2 in 17T 12/24 DP¹⁾(SAE J744 - 38-4 (C-C))

NG	A ₁	A ₂	A ₃ ³⁾	A _{3a} ⁴⁾	A ₄ ²⁾
100	13.31 (338)	0.41 (10.5)	2.56 (65)	—	M16 x 2, continuous
140	13.78 (350)	0.42 (10.8)	2.95 (75)	—	M16 x 2, 0.94 (24) deep
	13.78 (350)	0.40 (10.3)	—	2.72 (69.1)	M16 x 2, 0.94 (24) deep

- 3) Coupling without stop
- 4) Coupling with stop

1) 30° pressure angle, flat root, side fit, tolerance class 5
2) Thread according to DIN 13, observe the general instructions on page 51 for the maximum tightening torques.

Before finalizing your design request a certified installation drawing.
Dimensions in inches and (mm).

HYDRAULIC PUMP

HSP-10VO

SAE SIZE

DIMENSIONS THROUGH DRIVE

K17 flange ISO 3019-1 (SAE J744 - 152-4 (A))
Coupling for splined shaft according to ANSI B92.1a

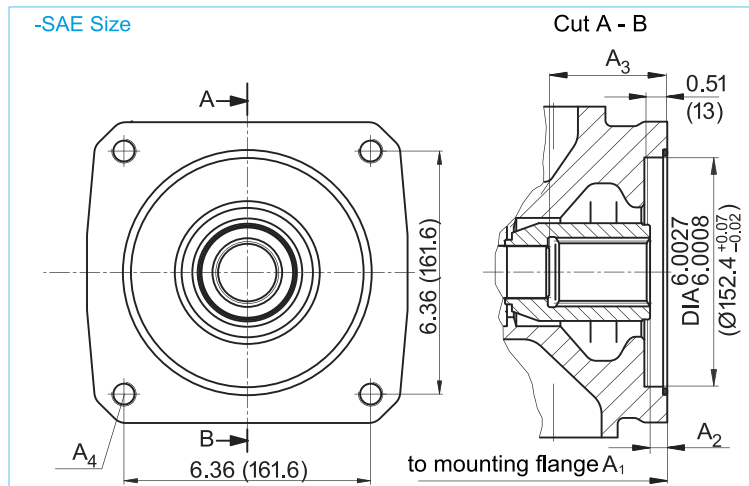

1 3/4 in 13T 8/16 DP¹⁾(SAE J744 - 44-4 (D))

NG	A ₁	A ₂	A ₃	A ₄ ²⁾
140	13.78 (350)	0.43 (11)	3.04 (77.3)	M6 x 2, continuous

Before finalizing your design request a certified installation drawing.
Dimensions in inches and (mm).

- 1) 30° pressure angle, flat root, side fit, tolerance class 5
- 2) Thread according to DIN 13, observe the general instructions on page 51 for the maximum tightening torques.

HYDRAULIC PUMP

HSP-10VO

SUMMARY MOUNTING OPTIONS

ISO — mounting flange

Through-drive ¹⁾ Flange ISO 3019-2	Coupling for splined shaft	Short des. des.	Mounting option – 2nd pump		Gear pump design(NG)	Through drive available for NG
			HSP-10VO/31 NG (shaft)	HSP-10VO/5x NG (shaft)		
80-2	3/4 in	KB2	18 (S \ R)	10 (S)	–	18 to 140
100-2	7/8 in	KB3	28 (S \ R)	–	–	28 to 140
	1 in	KB4	45 (S \ R)	–	–	45 to 140
125-2	1 1/4 in	KB5	71 (S \ R)	–	–	71 to 140
	1 1/2 in	KB6	100 (S)	–	–	100 to 140
180-4 (4-holeB)	1 3/4 in	KB7	140 (S)	–	–	140

Parallel shaft key

Through-drive ¹⁾ Flange ISO 3019-2	Coupling for splined shaft	Short des. des.	Mounting option – 2nd pump		Radial piston pump	Through drive available for NG
			HSP-10VO/31 NG (shaft)	HSP-10VO/5x NG (shaft)		
80-2	3/4 in	K57	–	–	R4	28 to 140

SAE — mounting flange

Through-drive ¹⁾ Flange ISO 3019-1	Coupling for splined shaft	Short des. des.	Mounting option – 2nd pump		Gear pump design(NG)	Through drive available for NG
			HSP-10VO/31 NG (shaft)	HSP-10VO/5x NG (shaft)		
82-2 (A)	5/8 in	K01	18 (U)	10 (U)	F (5 to 22)	18 to 140
	3/4 in	K52	18 (S \ R)	10 (S) 18 (U) 18 (S \ R)	–	18 to 140
101-2 (B)	7/8 in	K68	28 (S \ R) 45 (U \ W) ¹⁾	28 (S \ R) 45 (U \ W) ¹⁾	N/G (26 to 49)	28 to 140
	1 in	K04	45 (S \ R) –	45 (S \ R) 60 \ 63 (U \ W) ²⁾	–	45 to 140
127-2 (C)	1 1/4 in	K07	71 (S \ R) 100 (U) ³⁾	85 (U \ W) ³⁾ 100 (U \ W)	–	71 to 140
	1 1/2 in	K24	100 (S)	85 (S) 100 (S)	–	100 to 140
152-4 (4-hole D)	1 3/4 in	K17	140 (S)	–	–	140

1) Not for main pump NG28 with K68

2) Not for main pump NG45 with K04

3) Not for main pump NG71 with K07

HYDRAULIC PUMP

HSP-10VO

COMBINATION PUMPS HSP-10VO + HSP-10VO

When using combination pumps it is possible to have multiple, mutually independent circuits without the need for a splitter gearbox.

When ordering combination pumps the model codes for the first and the second pump must be joined by a "+".

Order example :

HSP-10VO 100DFR1/31R-VSB12K04+

HSP-10VO 45DFR/31R-VSA12N00

If no further pumps are to be factory-mounted, the simple type code is sufficient. Included in the delivery contents of the pump with through drive are then: coupling and seal, with plastic cover to prevent penetration by dust and dirt.

It is permissible to use a combination of two single pumps of the same size (tandem pump), considering a dynamic mass acceleration force of maximum 10 g (= 98.1 m/s²) without an additional support bracket.

Each through drive is plugged with a non-pressure-resistant cover. Before commissioning the units, they must therefore be equipped with a pressure-resistant cover.

Through drives can also be ordered with pressure-resistant covers. Please specify in clear text.

For combination pumps comprising more than two pumps, the mounting flange must be calculated for the permissible moment of inertia.

Permissible mass moment of inertia

NG			18	28	45	71	100	140
Permissible mass moment of inertia static	T _m	lb-ft	369	649	1010	1593	2213	3319
		(Nm)	(500)	(880)	(1370)	(2160)	(3000)	(4500)
dynamic at 10g (98.1 m/s ²)	T _m	lb-ft	37	65	101	159	221	332
		(Nm)	(50)	(88)	(137)	(216)	(300)	(450)
Mass with through-drive plate	m	lbs	30.8	41.9	55	86	119	150
		(kg)	(14)	(19)	(25)	(39)	(54)	(68)
Mass without through drive (e.g. 2nd pump)	m	lbs	26.6	33	46	73	99	132
		(kg)	(12)	(15)	(21)	(33)	(45)	(60)
Distance center of gravity	l	in	3.54	4.33	5.12	5.91	6.30	6.30
		(mm)	(90)	(110)	(130)	(150)	(160)	(160)

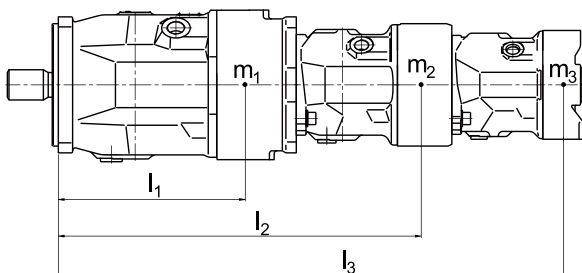

m₁ ∙ m₂ ∙ m₃ Mass of pumps [lbs (kg)]

l₁ ∙ l₂ ∙ l₃ Distance center of gravity [in (mm)]

$$T_m = (m_1 \cdot l_1 + m_2 \cdot l_2 + m_3 \cdot l_3) \cdot \frac{1}{12(102)} \text{ [lb-ft (Nm)]}$$

HYDRAULIC PUMP

HSP-10VO

INSTALLATION INSTRUCTIONS

General

The axial piston unit must be filled with hydraulic fluid and air bled during commissioning and operation. This must also be observed following a longer standstill as the axial piston unit empty via the hydraulic lines.

Especially with the installation position "drive shaft upwards" or "drive shaft downward", attention must be paid to a complete filling and air bleeding since there is a risk, for example, of dry running.

The case drain fluid in the motor housing must be directed to the reservoir via the highest case drain port (L1, L2, L3).

For combinations of multiple units, make sure that the respective case pressure in each unit is not exceeded. In the event of pressure differences at the case drain ports of the units, the shared case drain line must be changed so that the minimum permissible case pressure of all connected units is not exceeded in any situation. If this is not possible, separate case drain lines must be laid if necessary.

To achieve favorable noise values, decouple all connecting lines using elastic elements and avoid above-reservoir installation.

In all operating conditions, the suction line and case drain line must flow into the reservoir below the minimum fluid level. The permissible suction height h_S is a result of the overall pressure loss, but may not be greater than $h_{S\ max} = 31.50\ \text{inch}\ (800\ \text{mm})$. The minimum suction pressure at port S must also not fall below 12 psi (0.8 bar) absolute during operation.

Installation position

See the following examples 1 to 12.
Additional installation positions are available upon request.
Recommended installation positions: 1 and 3.

Below-reservoir installation (standard)

Below-reservoir installation means the axial piston unit is installed outside of the reservoir below the minimum fluid level.

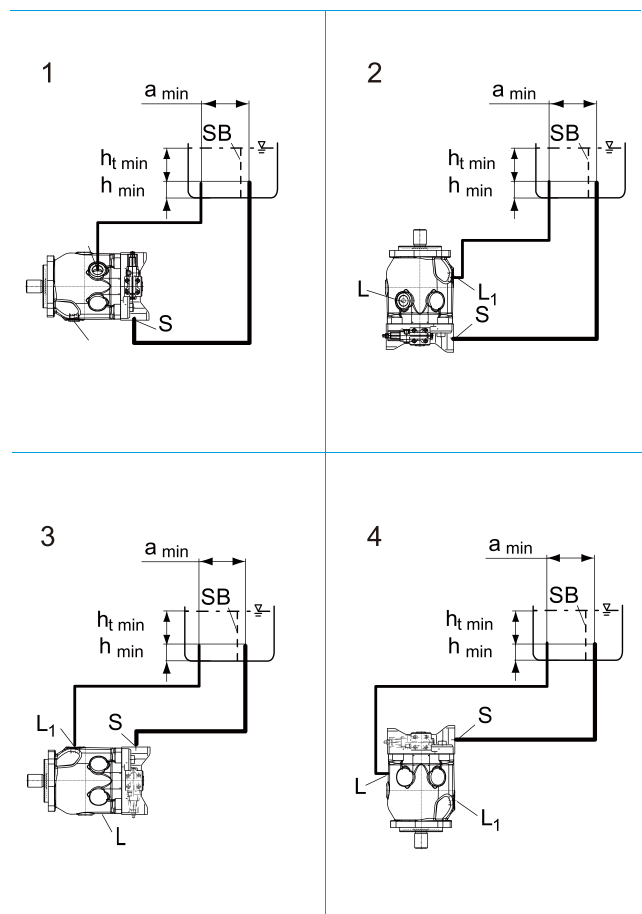

Installation position	Air bleed	Filling
1	L	S + L ₁
2	L ₁	S + L
3	L ₁	S + L
4	L	S + L ₁

please following page 50

HYDRAULIC PUMP

HSP-10VO

INSTALLATION INSTRUCTIONS

Above-reservoir installation

Above-reservoir installation means the axial piston unit is installed above the minimum fluid level of the reservoir.

To prevent the axial piston unit from draining, a height difference $h_{ES\ min}$ of at least 0.98 inch (25 mm) at port L 1 is required in installation position 6. Observe the maximum permissible suction height $h_{s\ max} = 31.50$ inches (800 mm)

A check valve in the case drain line is only permissible in individual cases. Consult us for approval.

Inside-reservoir installation

Inside-reservoir installation is when the axial piston unit is installed in the reservoir below the minimum fluid level.

The axial piston unit is completely below the hydraulic fluid.

If the minimum fluid level is equal to or below the upper edge of the pump, see chapter "Above-reservoir installation".

Axial piston units with electrical components (e.g. electric control, sensors) may not be installed in a reservoir below the fluid level.

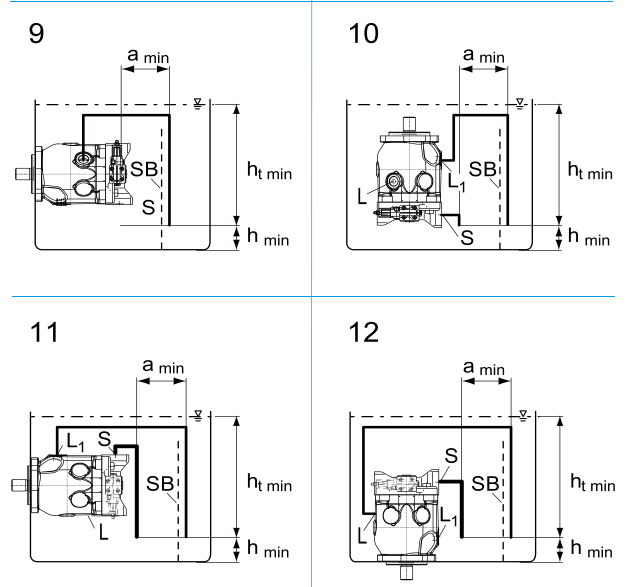
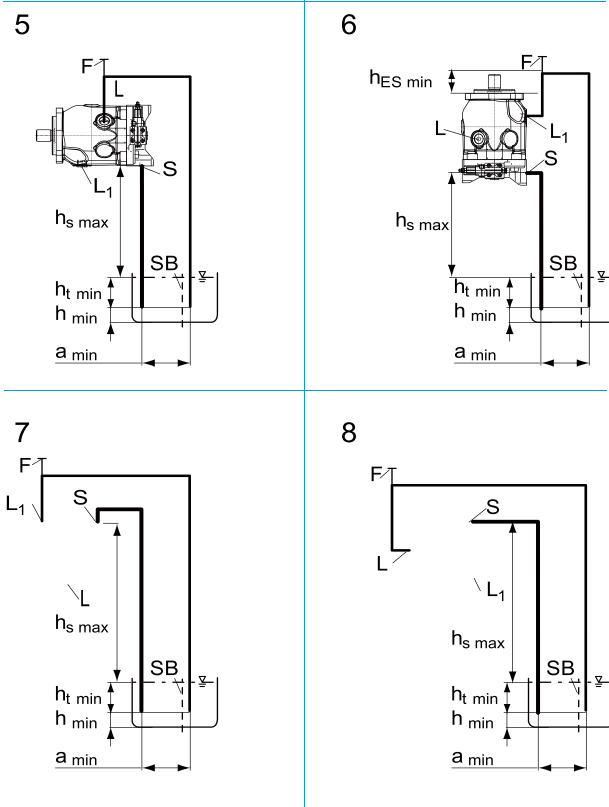

Installation position	Air bleed	Filling
5	F	L (F)
6	F	L ₁ (F)
7	F	S + L ₁ (F)
8	F	S + L (F)

Installation position	Air bleed	Filling
9	L	L \ L ₁
10	L ₁	L \ L ₁
11	L ₁	S + L \ L ₁
12	L	S + L \ L ₁

S	Suction port
F	Filling / air bleeding
L \ L ₁	Case drain port
SB	Baffle (baffle plate)
ht min	Minimum necessary immersion depth (7.87 inch (200 mm))
h min	Minimum necessary spacing to reservoir bottom (3.94 inch (100 mm))
hES min	Minimum necessary height needed to protect the axial piston unit from draining (0.98 inches (25 mm)).
hs max	Maximum permissible suction height (31.50 inch (800 mm))
a min	When designing the reservoir, ensure adequate distance between the suction line and the case drain line. This prevents the heated, return flow from being drawn directly back into the suction line.

HYDRAULIC PUMP

HSP-10VO

TIGHTENING TORQUES

– Fittings:

Observe the manufacturer’s instruction regarding the tightening torques of the used fittings.

– Mounting bolts:

For mounting bolts with metric ISO thread according to DIN 13 or thread according to ASME B1.1

– Female threads in axial piston unit :

The maximum permissible tightening torques $M_{G \max}$ are maximum values for the female threads and must not be exceeded. For values, see the following table.

– Threaded plugs :

For the metal threaded plugs supplied with the axial piston unit, the required tightening torques of the threaded plugs M_V apply. For values, see the following table.

ISO Ports Standard	Thread size	Maximum permissible tightening torque for female threads $M_{G \max}$	Required tightening torque for threaded plugs M_V	Size of hexagon socket of threaded plugs
DIN 385	M14 x 1.5	80 Nm	45 Nm	6 mm
	M16 x 1.5	100 Nm	50 Nm	8 mm
	M18 x 1.5	140 Nm	60 Nm	8 mm
	M22 x 1.5	210 Nm	80 Nm	10 mm
	M27 x 2	330 Nm	135 Nm	12 mm
DIN ISO 228	G 1/4 in	70 Nm	–	–

SAE Ports Standard	Thread size	Maximum permissible tightening torque for female threads $M_{G \max}$	Required tightening torque for threaded plugs M	Size of hexagon socket of threaded plugs
DIN 3852 ¹⁾	G1/4	52 lb-ft	–	–
		70 Nm	–	–
	M14 x 1.5	59 lb-ft	26 lb-ft	0.24 inch
		80 Nm	35 Nm	6 mm
DIN ISO 228	G1/4	52 lb-ft	22 lb-ft	0.24 inch
		70 Nm	30 Nm	6 mm
ISO 11926	7/16-20UNF-2B	29 lb-ft	13 lb-ft	3/16 in
		40 Nm	18 Nm	
	9/16-18UNF-2B	59 lb-ft	26 lb-ft	1/4 in
		80 Nm	35 Nm	
	3/4-16UNF-2B	118 lb-ft	52 lb-ft	5/16 in
		160 Nm	70 Nm	
	7/8-14UNF-2B	177 lb-ft	81 lb-ft	3/8 in
		240 Nm	110 Nm	
1 1/16-12UN-2B	266 lb-f	125 lb-f	9/16 in	
	360 Nm	170 Nm		

¹⁾The tightening torques of the threaded plugs M_V apply for screws in the „dry“ state as received on delivery and in the „lightly oiled“ state for installation

HYDRAULIC PUMP

GENERAL INSTRUCTIONS

- The **HSP-10VO** pump is designed to be used in open circuit.
- Project planning, installation and commissioning of the axial piston unit require the involvement of qualified personnel.
- Before operating the axial piston unit, please read the appropriate instruction manual thoroughly and completely. If necessary, contact us.
- During and shortly after operation, there is a risk of burns on the axial piston unit and especially on the solenoids. Take appropriate safety measures (e.g. by wearing protective clothing).
- Depending on the operating conditions of the axial piston unit (operating pressure, fluid temperature), the characteristics may shift.
- Service line ports:
 - The ports and fastening threads are designed for the specified maximum pressure. The machine or system manufacturer must ensure that the connecting elements and lines correspond to the specified application conditions (pressure, flow, hydraulic fluid, temperature) with the necessary safety factors.
- The service line ports and function ports are only designed to accommodate hydraulic lines.
- Pressure cut-off and pressure control do not provide security against pressure overload. A separate pressure relief valve is to be provided in the hydraulic system.
- The data and notes contained herein must be adhered to.
- The product is not approved as a component for the safety concept of a general machine according to ISO 13849 / DIN EN ISO 13849.

NOTES

Dotted lines for writing notes.

RANGE OF PRODUCTS



SINGLE • DOUBLE • THRU-DRIVE VANE PUMPS



VARIABLE DISPLACEMENT PUMP HSP-10V



DIRECTIONAL CONTROL VALVE



HYDRAULIC CYLINDERS

hydraut

hydraut.com